

2024

VER INDICE  
GO TO INDEX

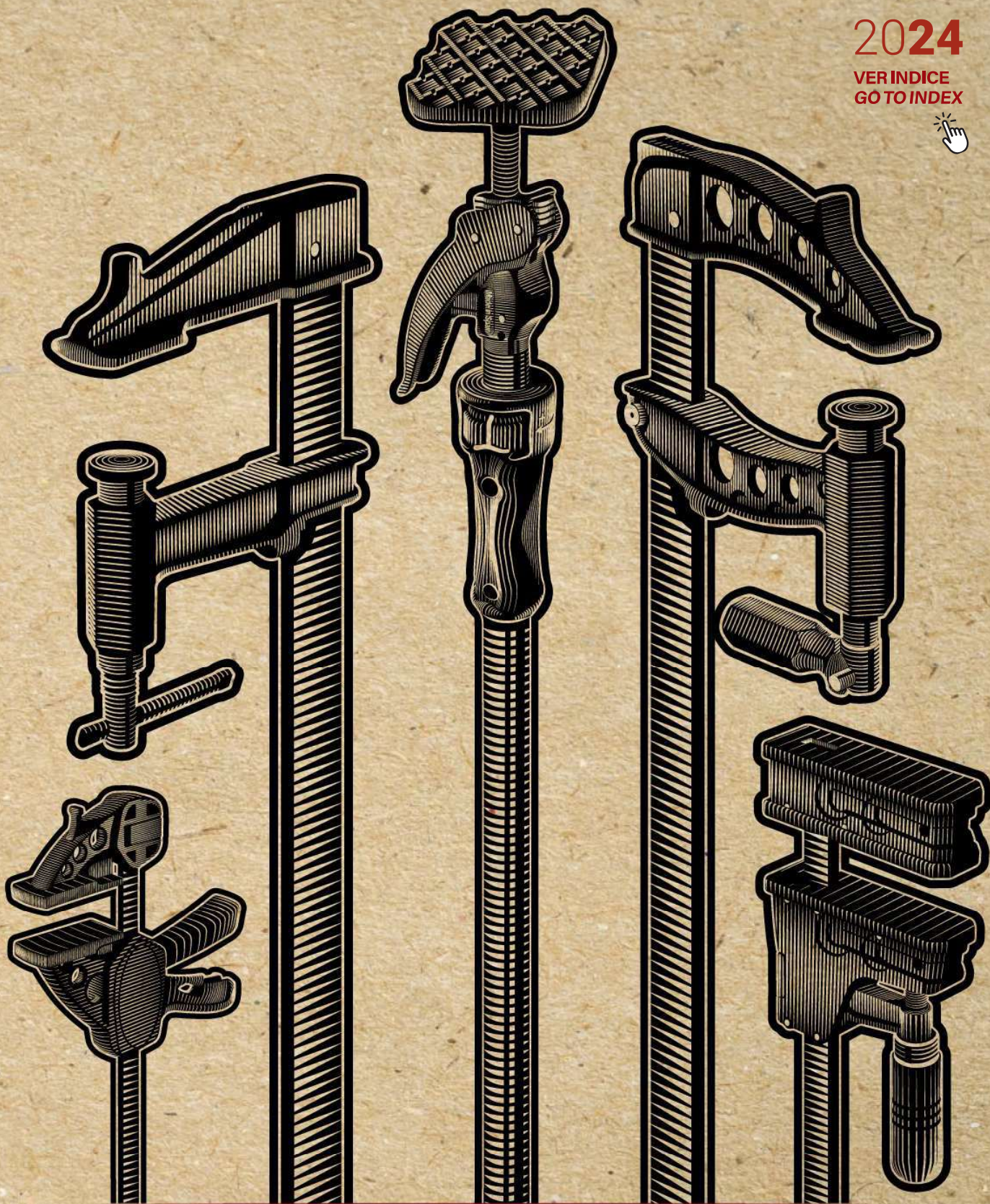

EST. 1957

**PIHER**®

# INDUSTRIAS PIQUERAS · 60 AÑOS DE EMPRESA FAMILIAR

## PIQUERAS INDUSTRIES · 60 YEARS OF FAMILY COMPANY HISTORY

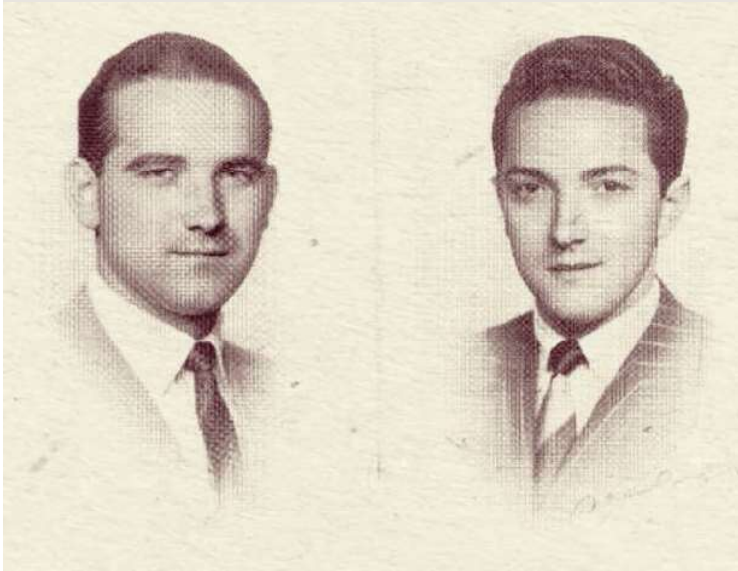

Ricardo y Juan Piqueras, hermanos Piqueras, fundadores de PIHER (1957).  
*Ricardo and Juan Piqueras, Piqueras brothers, founders of PIHER (1957).*

Nuestras herramientas son la mejor solución para los trabajos más exigentes gracias a nuestra especialización en herramientas de sujeción durante más de 60 años y la constante mejora en materiales y producción.

El sistema de émbolo patentado por los hermanos Ricardo y Juan Piqueras es el verdadero origen de la fabricación en serie de las herramientas PIHER.

*Our tools are the best solution for the most demanding jobs thanks to our specialization in clamping tools over more than 60 years and our constant improvement in materials and production.*

*The piston system patented by the brothers Ricardo and Juan Piqueras is the true origin of the mass production of PIHER tools.*

Actualmente la fábrica PIHER sigue ligada a la tierra que la vio nacer, La Rioja, y a los valores familiares con los que fue fundada.

Desde entonces PIHER ha mantenido el cuidado de la fabricación tradicional de herramientas junto con el desarrollo de nuevas patentes e innovación que la caracteriza desde sus inicios.

*Even now, the PIHER factory is still closely tied to the place where it all began, La Rioja, and with the same family values, it was founded on.*

*Ever since its founding has continued with traditional clamping tool manufacture enhanced by their constant improvement, new patents and innovations. Here resides our hallmark.*

Sede original de PIHER (Logroño, 1968)  
*Original PIHER factory (Logroño, 1968)*



Sede de la fábrica y oficinas de Industrias Piqueras S.A. (Logroño, 2023)  
*Office and factory headquarters of Industrias Piqueras S.A. (Logroño, 2023)*

# SOLIDEZ Y CALIDAD DE FABRICACIÓN PROPIA

## STURDINESS AND OWN MANUFACTURING QUALITY

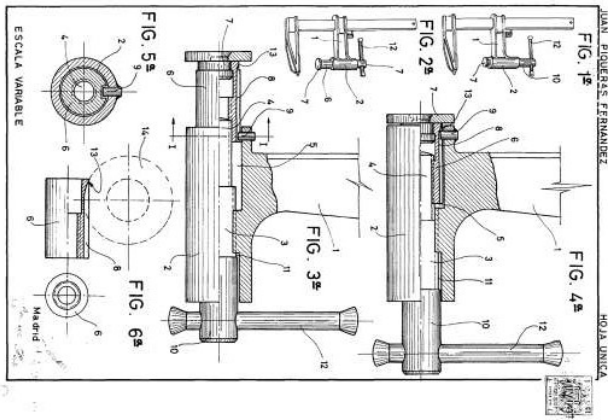

Una de las primeras patentes aprieto de émbolo, Juan Piqueras (1957)  
*One of the first piston clamp patents, Juan Piqueras (1957)*

Nuestras herramientas son popularmente conocidas por su solidez, eficacia y versatilidad. PIHER se ha convertido en la elección inmediata del sector profesional cuando se demanda durabilidad y fiabilidad.

Gracias a nuestro departamento de I+D+I desarrollamos continuamente nuevos diseños de herramientas y mejoras a nuestras herramientas clásicas que implementamos de inmediato en nuestra fábrica.

*Our products are well known for their sturdiness, efficiency and versatility. PIHER has become the first choice in the professional sector when both reliability and durability are essential.*

*Thanks to our R+D+I department, we continually develop new tool designs and improvements to our classic tools which we immediately implement in our factory.*

### PREMIOS Y CERTIFICADOS

AWARDS & CERTIFICATES



LYON d'OR Award · Eurobois · France · 2011  
 Puntal · Premio a la innovación  
 Multiprop · Outstanding New Product



TOP PRODUCT OF THE YEAR · Professional Builder Magazine  
 Reino Unido · 2015  
 Multiprop · Outstanding New Product



ISO 9001  
 COMPROMISO CON LA CALIDAD  
 QUALITY COMMITMENT



ISO 14001  
 COMPROMISO CON EL MEDIO AMBIENTE  
 ENVIRONMENTAL COMMITMENT



Nuevo diseño del cabezal móvil de fundición para el modelo Maxipress E (2022)  
*New design of the cast iron Maxipress E moving jaw (2022)*

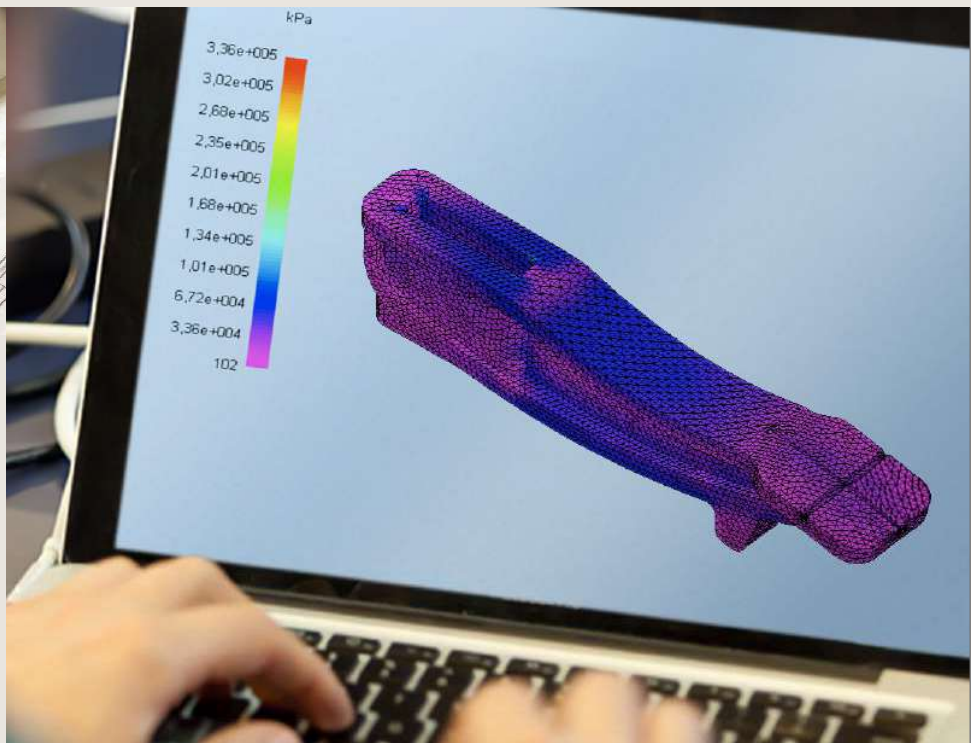

# DESDE EUROPA A TODO EL MUNDO

## FROM EUROPE TO THE WHOLE GLOBE

En 1995 comenzamos a asistir a ferias internacionales y nos abrimos al mercado exterior. Desde entonces las exportaciones han crecido considerablemente.

Nuestro mercado principal es el continente europeo y hemos desarrollado un tejido comercial y logístico que permite a nuestras herramientas estar presentes alrededor de todo el mundo.

*Our entry into foreign markets began in 1995 going to our first international fairs.*

*The European continent is our main market, but we have developed a business & logistical network which enables our tools to be available all over the world.*



El 80% de las herramientas que vendemos son diseñadas y ensambladas en nuestra propia fábrica de Logroño. La red de proveedores y materiales que necesitamos para fabricar esas herramientas no se extiende más allá de 800km de distancia de nuestra sede.

*80% of the tools we sell are designed and assembled in our own factory in Logroño. The network of suppliers and materials that we need to manufacture these tools does not go beyond 800km from our headquarters.*

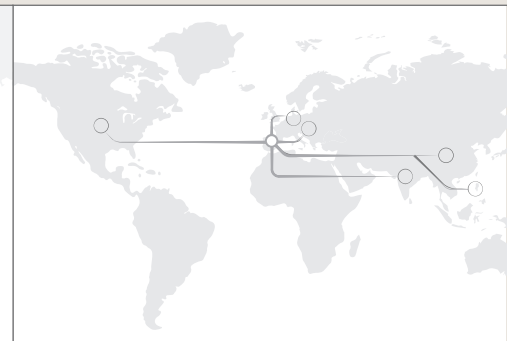

Desde los años 90 nuestro catálogo incluye herramientas fabricadas en otras partes del mundo, bajo el filtro de calidad PIHER. Estas herramientas suponen el 20% de nuestras ventas.

*Since 1990 we have included in our catalogue clamping tools manufactured abroad with the same quality guarantee. These tools represent 20% of our sales.*

# SOSTENIBILIDAD

## ENVIRONMENTAL AND SOCIAL SUSTAINABILITY



### ENERGÍA LIMPIA CLEAN ENERGY



Nuestra instalación de paneles solares, generan al año la misma cantidad de electricidad que la que consumimos.

*Our installation of solar panels generates the same amount of electricity per year as we consume*



La climatización y todos los procesos productivos de nuestra fábrica utilizan la electricidad como fuente de energía.

*The air conditioning and all the production processes in our factory use electricity as their energy source.*



Somos socios y nos abastecemos de energía certificada 100% renovable a través de ésta cooperativa de energía.

*We are partners and we supply ourselves with certified 100% renewable energy through this energy cooperative.*



### HUELLA ECOLÓGICA ECOLOGICAL FOOTPRINT



Garantía de por vida contra defectos de fabricación y venta de repuestos para la mayoría de nuestros productos.

*Lifetime guarantee against manufacturing defects and spare part sales for most of our products.*



Avanzamos en la eliminación de plásticos en el embalaje en favor del uso del cartón.

*We are making progress in the elimination of plastics in packaging in favour of the use of cardboard.*



Elegimos tratamientos de materiales y acabados que reducen los residuos y el impacto ambiental.

*We choose treatments of materials and finishes that reduce waste and environmental impact.*



Priorizamos proveedores de cercanía y materiales reciclados.

*We prioritise local suppliers and recycled materials.*



### SOSTENIBILIDAD SOCIAL SOCIAL SUSTAINABILITY



Formamos parte de la Economía del Bien Común.

*We are part of the Economy for the Common Good.*



Somos socios y trabajamos con Fiare, proyecto de banca ética sin ánimo de lucro.

*We are partners and work with Fiare, a non-profit ethical banking project.*



Utilizamos en nuestro día a día y financiamos proyectos de software libre.

*Used in our daily working and to finance free software projects.*



Parte de nuestros trabajos se realizan en asociaciones de ayuda a las personas con discapacidad.

*Part of our work is carried out through associations that help people with disabilities.*

# PATROCINIO Y COLABORACIÓN

## SPONSORSHIP & COLLABORATIONS



Albaola trabaja en la reconstrucción histórica del San Juan, un ballenero vasco del s.XVI, reconocida por la UNESCO. Y desarrolla una escuela de carpintería de riberapara recuperar las técnicas tradicionales.

*We cooperate with Albaola to supply every clamping tool they need. They are building a historical replica of the San Juan, a whaling ship built in the 16th century in the same port where they are located now. This project has Unesco recognition.*



Piher es patrocinador oficial de la competición de formación profesional Spain Skills en las modalidades de Carpintería y Ebanistería. Hemos aportado nuestras herramientas de sujeción para cada uno de los jóvenes participantes.

*We have also been an official sponsor of the Spain Skills 2022 vocational training college competition in the Carpentry and Joinery categories. We have provided our clamping tools for each of the young participants.*



También colaboramos con Profemadera, la asociación española de Profesores/as de enseñanzas de Madera y Mueble.

*We also collaborate with Profemadera, the Spanish Association of Woodworking and Cabinet Making teachers.*

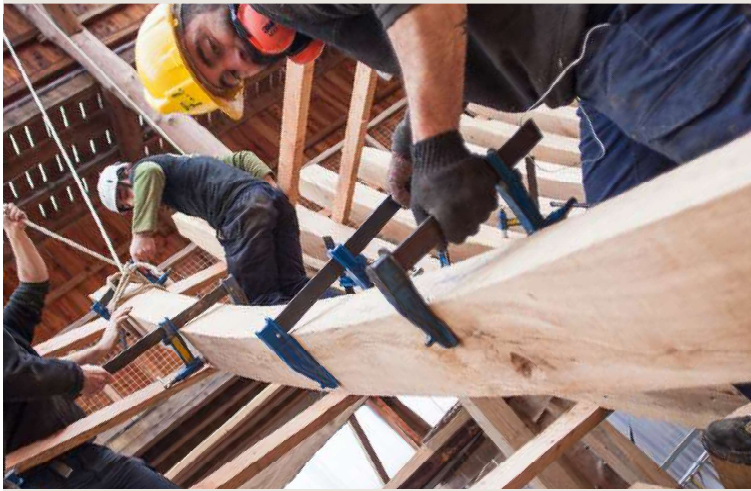

p.10



PUNTALES  
MULTIPROPS



p.18



MULTICLAMP



p.26



FAMILIA ROJA  
RED LINE



p.31



p.32



CLÁSICOS AZULES  
CLASSIC BLUE



p.37



p.40



APRIETOS G  
G CLAMPS



p.40

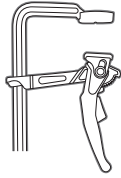

APRIETOS DE FORJA  
FORGED CLAMPS

p.42



PRL400

p.45

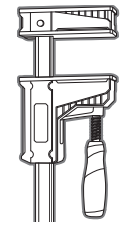

PARALELO GRANDE  
LARGE PARALLEL  
CLAMP

NEW

p.46

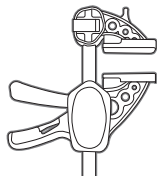

FAMILIA QUICK  
QUICK LINE

p.52



DE PALANCA  
RATCHET CLAMPS

p.54

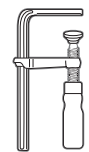

PARA GUÍAS Y  
ORIFICIOS  
HOLE AND GUIDE  
CLAMPS

p.54

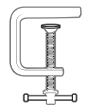

DE MESA  
TABLE CLAMPS

p.55



PINZAS  
SPRING CLAMPS

p.58



PRENSA DE FELJE  
DE ACERO  
STEEL BAND CLAMP

p.60

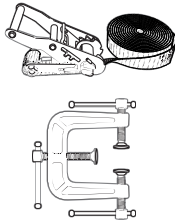

PRENSA DE BANDA  
STEEL BAND CLAMP

MOD. 3T

p.61



APLACANTOS  
EDGE-GRIP CLAMP

p.61



APLACANTOS  
EDGE-GRIP CLAMP

NEW

p.62



BOW PRODUCTS

p.66

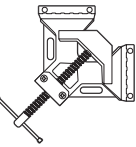

PRENSAS DE ÁNGULO  
ANGLE CLAMPS

p.67

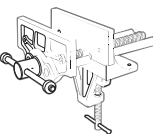

TORNILLOS DE BANCO  
BENCH VICES

p.69

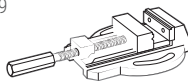

MORDAZAS  
DRILL VICES

p.70



PARA MESA DE  
ORIFICIOS  
FOR HOLE TABLES

NEW

p.76

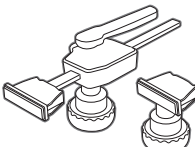

TCH · APRIETO  
HORIZONTAL

TCH · HORIZONTAL  
TOGGLE CLAMP

NEW

p.80



TS · PERNO  
UNIVERSAL PARA  
MESA DE SOLDADURA  
TS · UNIVERSAL  
BOLT & STOPS FOR  
WELDING TABLES

NEW

p.82

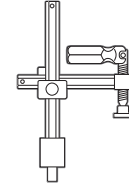

TCS · APRIETO DE  
MESA  
TCS · TABLE CLAMP

NEW

p.83

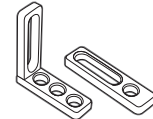

TF · POSICIONADORES  
TF · STOPS

NEW

p.84

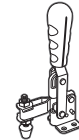

GRAPAS  
TOGGLE CLAMPS

p.87

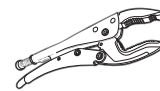

TENAZAS AJUSTABLES  
LOCKING PLIERS

p.93



MAGNÉTICAS PARA  
SOLDADURA  
MAGNETIC TOOLS  
FOR WELDING

p.94



EXTRACTORES  
PULLERS

p.102

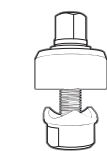

PERFORADORES  
PUNCHERS

p.104

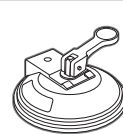

VENTOSAS  
SUCTION CUPS

p.108

























ELEVADORES Y  
TRANSPORTADORES  
LIFTERS &  
TRANSPORTERS

p.110



EXPOSITORES  
DISPLAYS



	Producción PIHER · <i>PIHER Production</i>
	Carpintería y trabajos de madera · <i>Woodworking &amp; Carpentry</i>
	Trabajos ligeros · <i>Light work</i>
	Metal y Soldadura · <i>Metalworking &amp; Welding</i>
	Construcción · <i>Building</i>
	Automovil y Mecánica · <i>Motor &amp; Mechanics</i>
	Plástico sin Aceite, No deja mancha · <i>Oil free reinforced plastic, no marks left</i>
	Herramienta para personalizar por el usuario · <i>Tool to customise by the user</i>
	Fuerza Máxima · <i>Maximum Pressure</i>
	Grosor de la Llanta · <i>Bar Thickness</i>
	Abertura máxima · <i>Maximum opening</i>
	Profundidad máxima · <i>Maximum depth</i>
	Profundidad a eje de tornillería · <i>Clamping depth</i>
	Diámetro · <i>Diameter</i>
	Unidades por caja · <i>Units per box</i>
	Envase Blister · <i>Blister packaging</i>
	Longitud mínima del puntal · <i>Minimum Multiprop length</i>
	Longitud máxima del puntal · <i>Maximum Multiprop length</i>
	Capacidad de succión en posición horizontal · <i>Maximum Suction capacity (Horizontally)</i>
	Capacidad de succión en posición vertical · <i>Maximum Suction capacity (Vertically)</i>
	Ancho x Alto de viga · <i>Width and height of bar clamp</i>
	Longitud de una pinza · <i>Spring clamp length</i>
	Amperios de Intensidad eléctrica · <i>Electric current in amps</i>
Tn	Tonelada fuerza · <i>Ton-force</i>

# PUNTALES MULTIPROPS

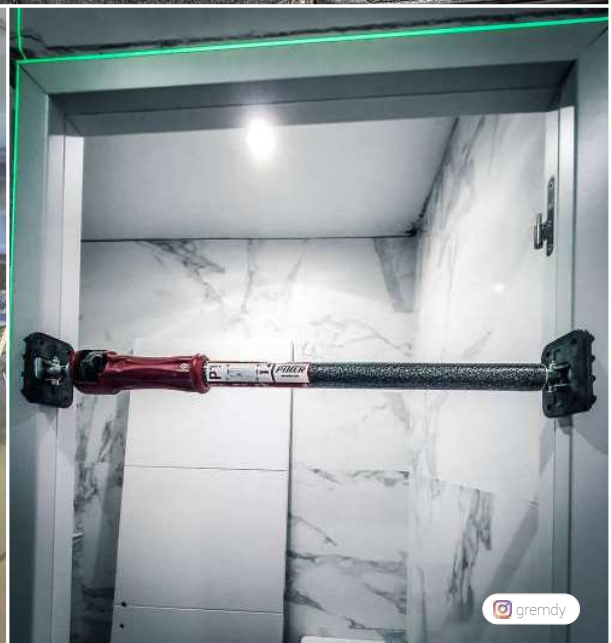

# PUNTALES MULTIPROPS

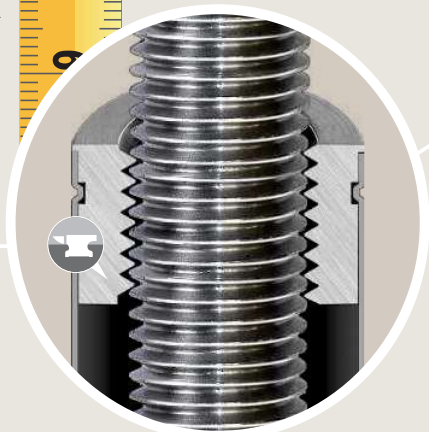

Expansión extra regulable al milímetro, con casquillo roscado fabricado en acero.  
*Accurate screw adjusted extra expansion with threaded bushing made of steel.*

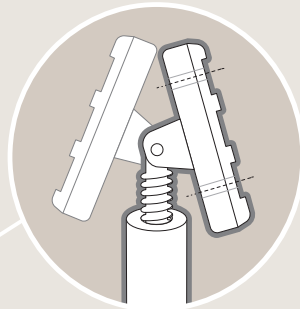

Zapatas antideslizantes adaptables a ángulos distintos y con orificios para amarrar a superficies.

*Tilting non-slip pads adjustable to any angle with holes to assemble to any surface.*

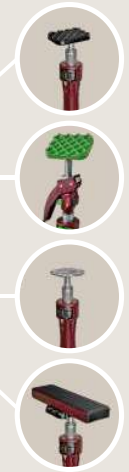

Sistema multidisco consigue expansión rápida y freno inmediato.

*Multi-disc system for quick expansion and instant braking*

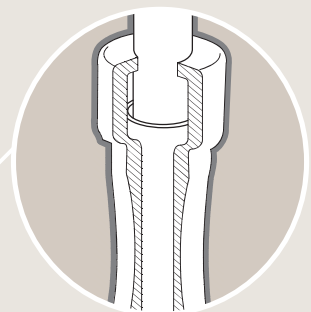

Mango de nylon reforzado con fibra de vidrio

*Nylon fibreglass reinforced handle.*



Tubos de acero de 1mm  
*1mm thick steel tubes.*

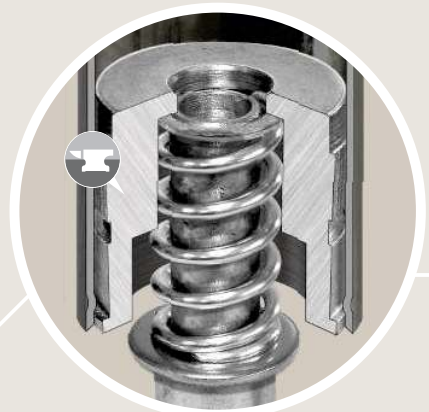

Sistema de muelle para fijación rápida, con casquillo fabricado en acero.

*Spring mechanism for quick locking, with threaded bushing made of steel.*

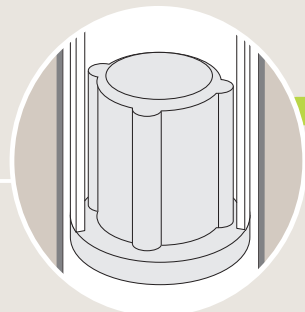

NEW

Nuevo amortiguador que mejora el guiado entre tubos, evita ruidos por vibración y suaviza el golpe de caída del tubo interior.

*New shock absorber that improves guidance between tubes, prevents vibration noise and softens the shock of the inner tube falling.*



**PUNTALE DE ESPANSIÓN · MULTIPROP**



HASTA · UP TO  
**300  
KG**



Las cargas aconsejadas son el resultado de aplicar un coeficiente de seguridad de 1,5 a la carga testada. Por ejemplo, si la carga aconsejada es de 300Kg en el test hemos aplicado 450Kg y la herramienta no ha sufrido ningún deterioro.\*

*The suggested loads are the result of using a safety margin of 1.5 in each test. For example: if the suggested load is 300Kg in the test we have applied 450Kg and the tool still shows no damage.\**

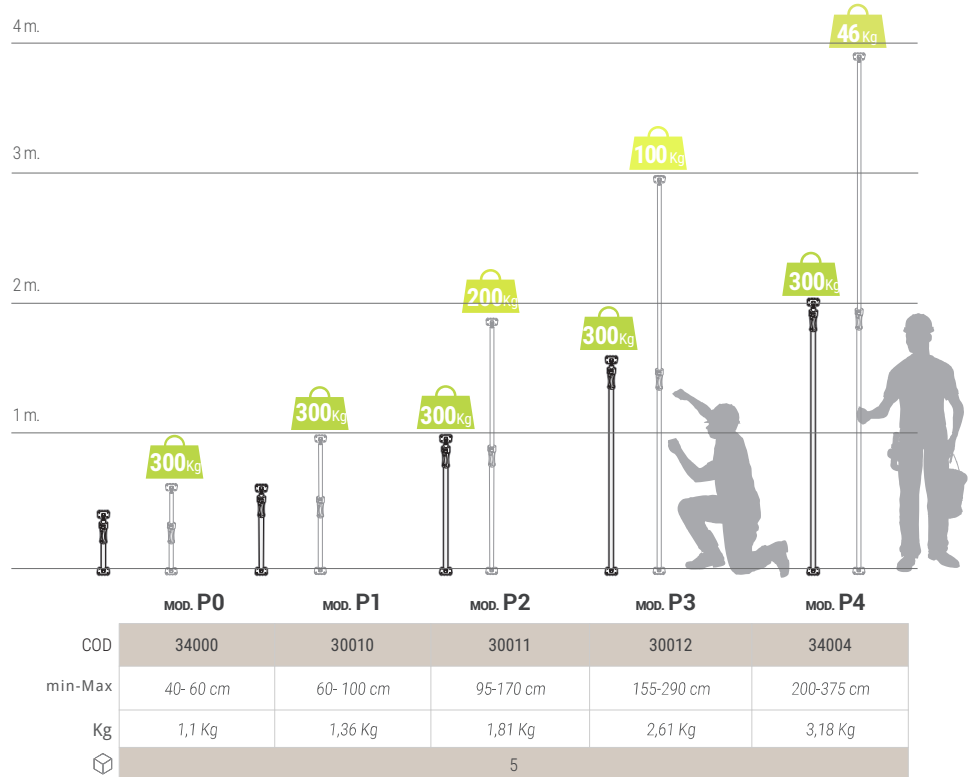

\* No nos hacemos responsables del mal uso que se haga del puntal.  
Lean atentamente las instrucciones de uso mantenimiento y almacenamiento que adjuntamos en cada herramienta.

\* We are not responsible for any misuse of the multiprop.  
Carefully read the instructions for use, maintenance and storage that we attach to each tool.

**SISTEMA DE ACCESORIOS PARA PUNTALES · MULTIPROP ACCESSORIES SYSTEM**

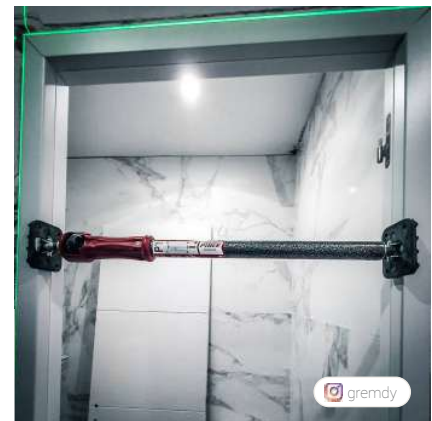
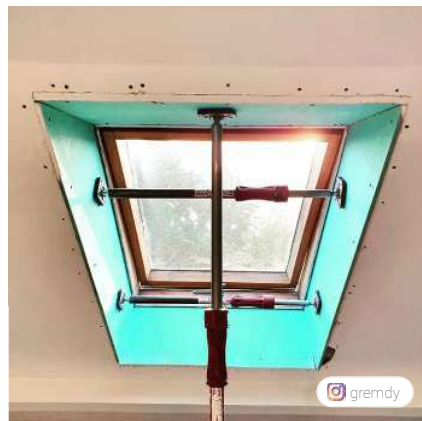



## REPUESTO DE ZAPATAS · SPARE PADS



COD	Kg	📦
34504	0,26	1

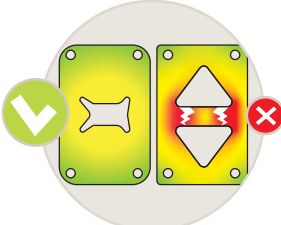

Núcleo de acero con diseño macizo que reparte la presión igualmente por toda la zapata.  
*Steel core with a solid design that distributes the pressure evenly throughout the pad.*



COD	Kg	📦
34502	0,10	1

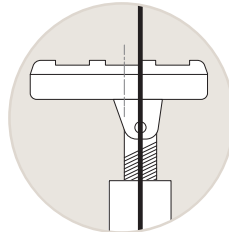

Eje descentrado permite usar el puntal pegado a paredes o suelos.  
*Offset axis allows the prop to be used when attached to walls or floors.*

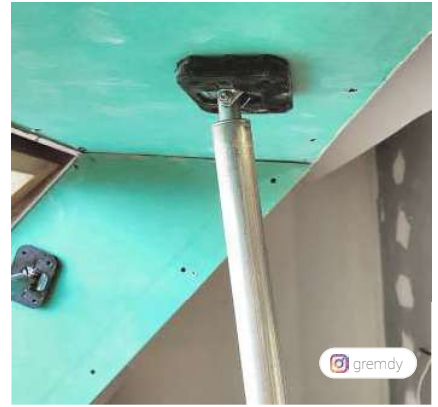
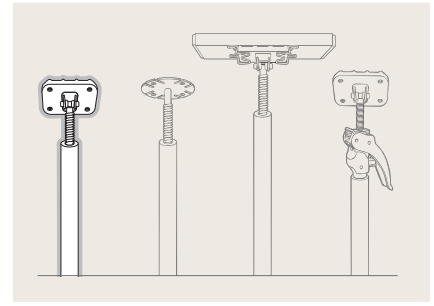
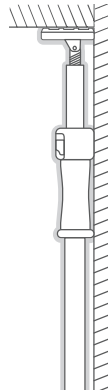

## JUEGO DE ZAPATAS FIJAS · FIXED PAD KIT



COD	Kg	📦
34039	0,39	1

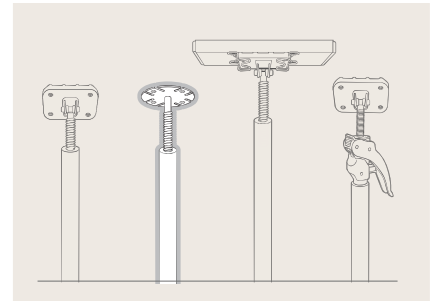
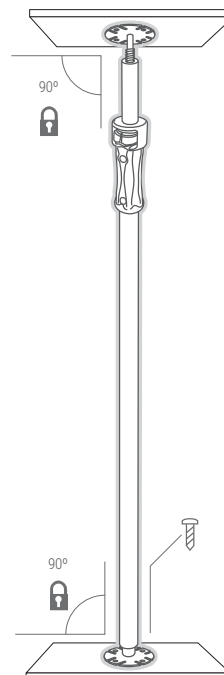

- Fabricado en acero
- Alojamiento para tornillos y ranuras que permiten fijar sobre ellas maderas, metales, etc.
- Mantienen siempre los apoyos paralelos
- Bloquean el sistema de muelle para mejorar la precisión y seguridad en trabajos de nivelación.
- Wholly in steel
- Screw holes and slots for fixing metal or wooden supports.
- Keeps supports parallel
- Locks Multiprop spring system to improve accuracy and security in levelling work

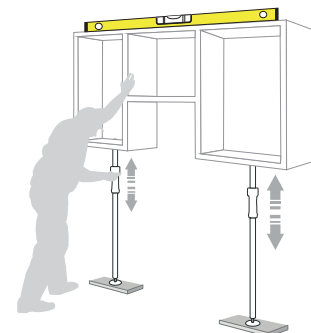



**ZAPATA EXTRA LARGA ANTIDESLIZANTE · EXTRA LONG ANTISLIP PADS**



Sistema rápido de colocación  
*Quick installation system*

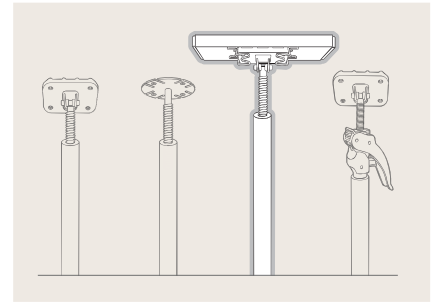

COD	A cm	B cm	Kg	📦
34036	6	20	0,13	4
34037	6	35	0,21	
34038	6	70	0,38	1



- Cuerpo de aluminio.
- Muelles de acero inoxidable.
- Superficie antideslizante de EPDM.

- *Aluminium body.*
- *Stainless steel springs.*
- *EPDM rubber anti-slip surface.*

**ACCESSORY ARM+ · ACCESSORY ARM+**



COD	Kg	📦
34089	0,51	2

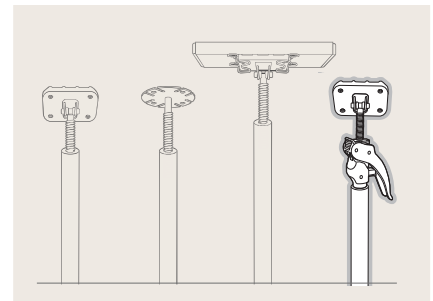
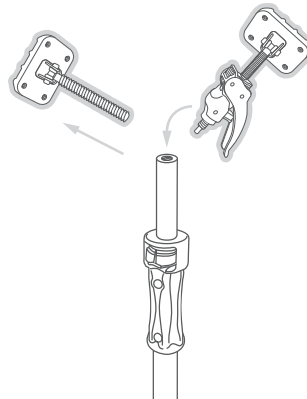

- Fácil de usar con una sola mano.
- 100Kg de carga máxima.
- Fabricado en acero y Nylon con fibra de vidrio.
- Zapata antideslizante ajustable a ángulo distintos.
- Acoplable a cualquiera de nuestros puntales.
- Inutiliza el giro del mango del Puntal

- *Easy single hand use*
- *100Kg (220lb) Load capacity*
- *Manufactured in steel and fibreglass reinforced nylon.*
- *Tilting non-slip pads adjustable to any angle*
- *For all of our multiprops.*





## MULTIPROP ARM+3



168cm

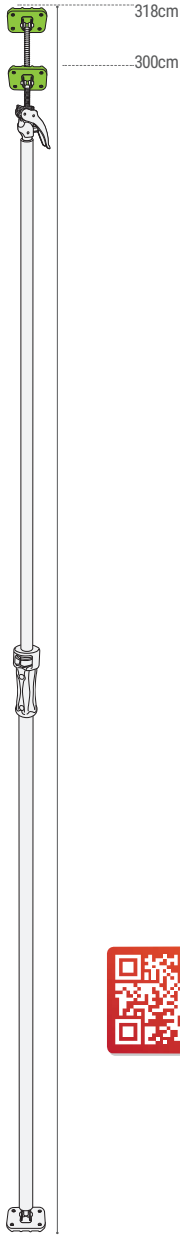
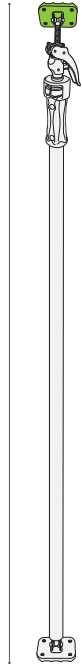

COD	kg	📦
34093	2.86	5

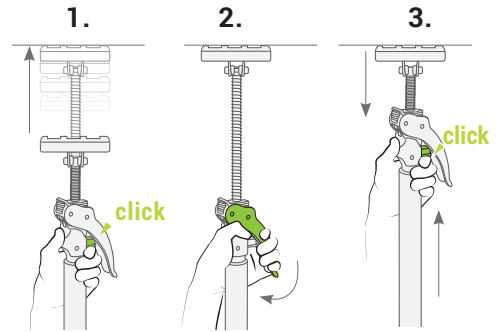

1. Acercamiento rápido.  
*Fast adjustment.*
2. Aumentar presión y distancia.  
*Increase pressure and distance.*
3. Comprimir muelle y liberar presión.  
*Compress spring and release pressure.*

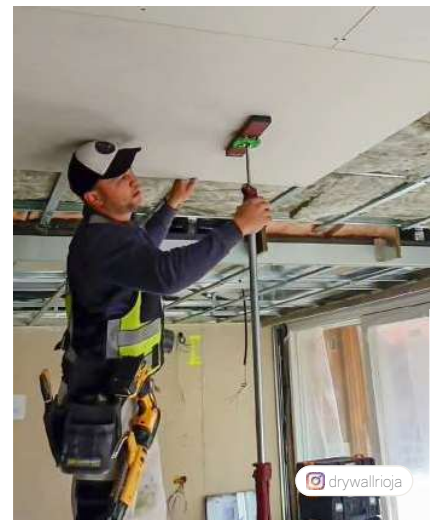



## PUNTALES MULTIPROP

### BOLSA DE TRANSPORTE DE PUNTALES · MULTIPROP HOLDALL

- Fabricado en algodón .
- Capacidad de carga máxima de 16kg
- *Made of cotton*
- *16Kg. Load Capacity .*



COD	Kg	Capacidad máxima Maximum capacity	Longitud Length	Kg Peso Max. Aconsejado Kg Max. Recommended Weight	📦
93049	0,65	5 x Puntal 3 Multiprop	165 cm	13	1
93050	0,70	4 x Puntal 4 Multiprop	210 cm	12	1

### SOPORTE REGULABLE MULTIUSOS · MULTIPURPOSE ADJUSTABLE HANGER

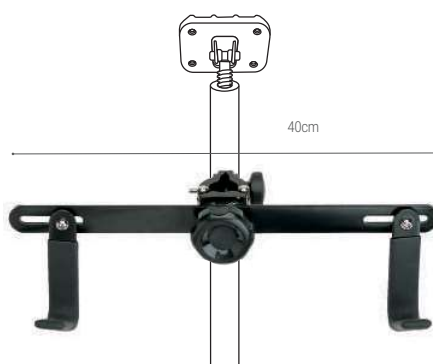

- Fabricado en acero.
- Ganchos con protectores de plástico.
- Autoajustable a tubos de Ø25mm a 30mm.
- Capacidad de carga de 25Kg.

- *Made of steel*
- *Hooks with plastic protectors.*
- *Adjustable for tubes from Ø25mm to 30mm.*
- *25Kg. Load Capacity .*

COD	Kg	📦
30015	0,9	1

### TRÍPODE · TRIPOD

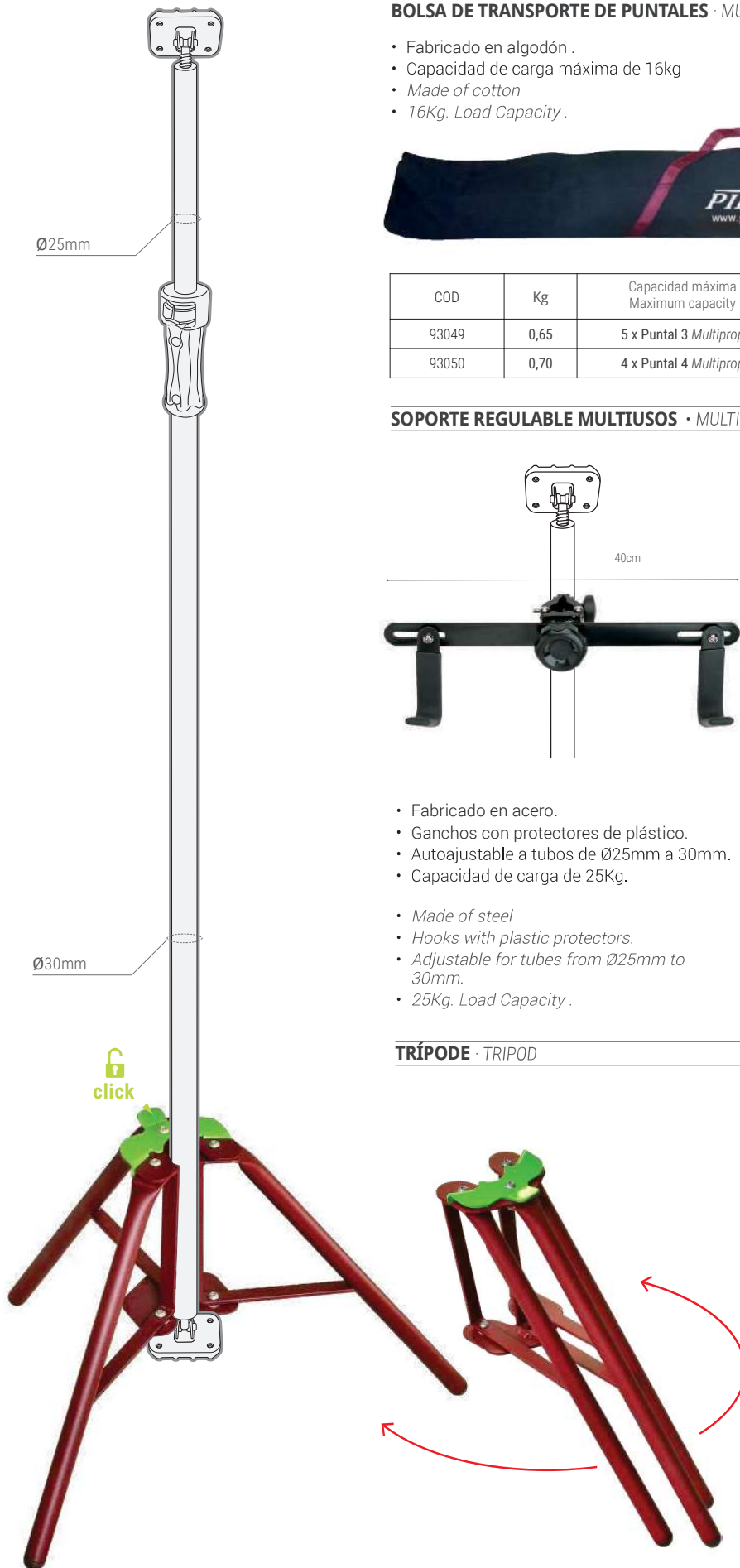

- Carga soportada: 300Kg
- Tubos y perfiles de acero.
- Para nuestros Puntales o tubos de Ø30mm
- Nuevo sistema de instalación y liberación con un sólo click.

- *Load capacity: 300Kg*
- *Welded tubes and profiles.*
- *For our Multiprop and for Ø30mm tubes.*
- *New Easy set up and One click release*

COD	Kg	📦
34050	1,84	1





## PUERTA MAGNÉTICA ANTIPOLVO · ANTI-DUST MAGNETIC DOOR SET



COD	Kg	
34110	2	1

- Auto-cierre magnético
- Abrir y cerrar sin usar las manos
- Incluye 2 Multiclamps con argolla, una puerta y un dintel de acero al carbono
- Para muros o puertas de contención de polvo y suciedad en áreas de trabajo
- Multiposición: elevada, a rás de suelo, de lado, central, etc.
- Anchura máxima entre puntales de 130cm
- Apertura de 2m de altura
- Reutilizable
- Utilizable con Puntales Piher (no incluidos)
- *Automatic magnetic strip closure*
- *No zip. No hands needed to open or to close.*
- *Includes 2 Multiclamps with a pressed eye, door and steel lintel.*
- *Self-closing action maintains a tight seal.*
- *For walls or doorways in anti-dust sealed work areas*
- *Multipositional door: ground level, elevated, centred, aside, etc.*
- *Maximum lintel length. 130cm*
- *Doorway aperture height: 200cm*
- *Reusable*
- *Usable with Piher Multiprops (not included)*

Transport bag included  
Bolsa de transporte incluida

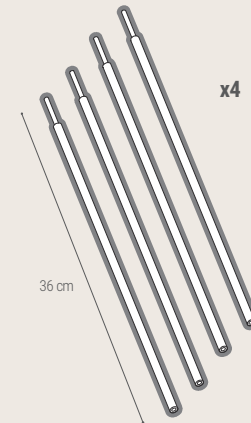
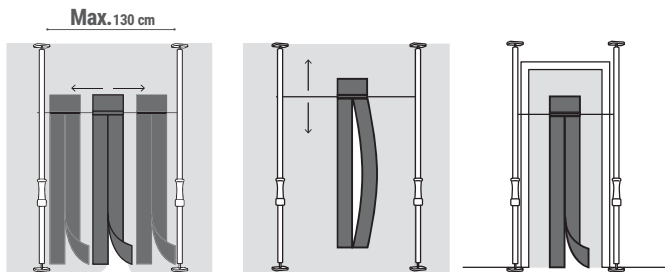

x4

COD. 34044

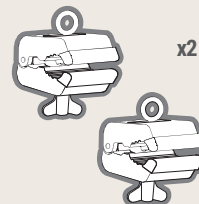

x2

**Puerta Magnética**  
Anti-Dust Magnetic Door



**Cómo instalar la Puerta Magnética**  
How to Install the Piher Anti-Dust Magnetic Door



**Cómo almacenar la Puerta Magnética**  
How to Store the Piher Anti-Dust Magnetic Door



# PUNTALES MULTIPROP

## KIT TRABAJO EN EL TECHO · CEILING WORK KIT



COD	Kg	📦
34017	8	1

Incluye · Included	COD	📦
Puntal P3 <i>Multitop P3</i>	30012	2x
Bolsa de transporte de Puntales <i>Multiprop Holdall</i>	93049	1x
Arm+	34089	2x
Zapata Extra Larga 35cm <i>Extra Long Antislip Pads</i>	34037	2x

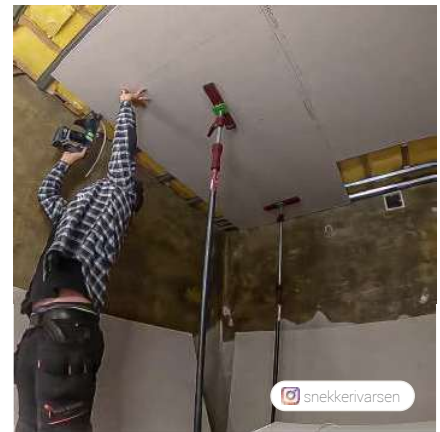

## KIT ANTIPOLVO · ANTI-DUST KIT



COD	Kg	📦
34018	8	1

Incluye · Included	COD	📦
Puerta Magnética Antipolvo <i>Anti-Dust Magnetic Door</i>	34110	1x
Puntal P3 <i>Multitop P3</i>	30012	2x
Bolsa de transporte de Puntales <i>Multiprop Holdall</i>	93049	1x
Cinta Adhesiva <i>Scotch tape</i>		1x
Film 200 x125cm <i>200 x125cm Plastic Sheet</i>		1x



# MULTICLAMPS



Mordazas de nylon con fibra de vidrio.  
*Nylon with fibreglass jaws.*

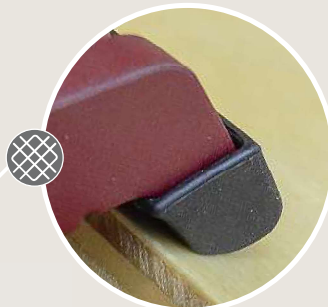

Protectores antideslizantes extraíbles.  
*Removable non-slip pads.*

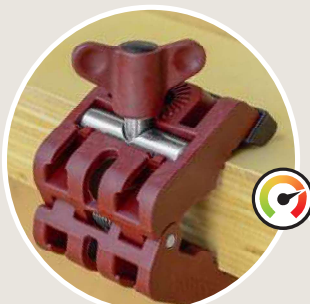

Potencia Máxima 75 Kg  
*Maximum pressure 75 Kg (330lb)*

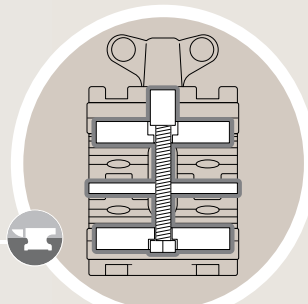

Husillo, eje y refuerzos de acero.  
*Screw, axis and reinforcements made of steel.*

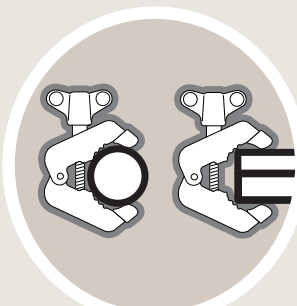

De uso en superficies planas, tubos y perfiles.  
*For flat and contoured surfaces, tubes...*

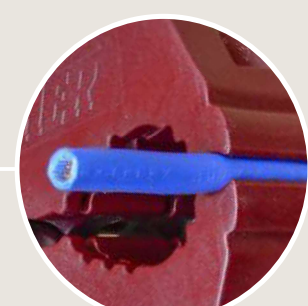

Útil para diámetros finos.  
*Useful for narrow diameters.*



## Ensambla lo que tú quieras.

Múltiples alojamientos para tornillos y tuercas M6, M8 y W1-4"

## Assemble what you want

Multiple screw and nut holes (M6, M8 and W 1-4")

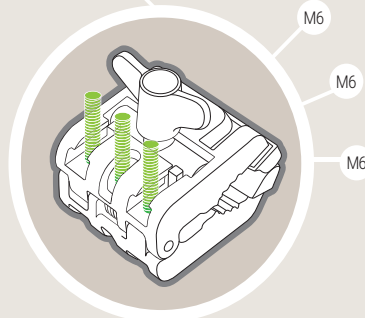
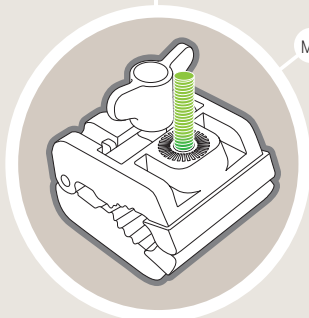
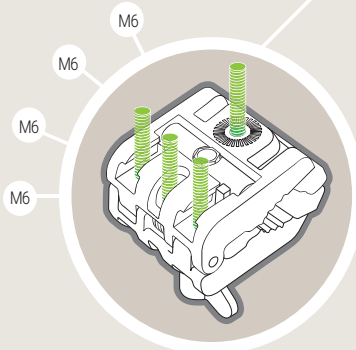
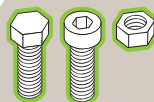

# MULTICLAMPS

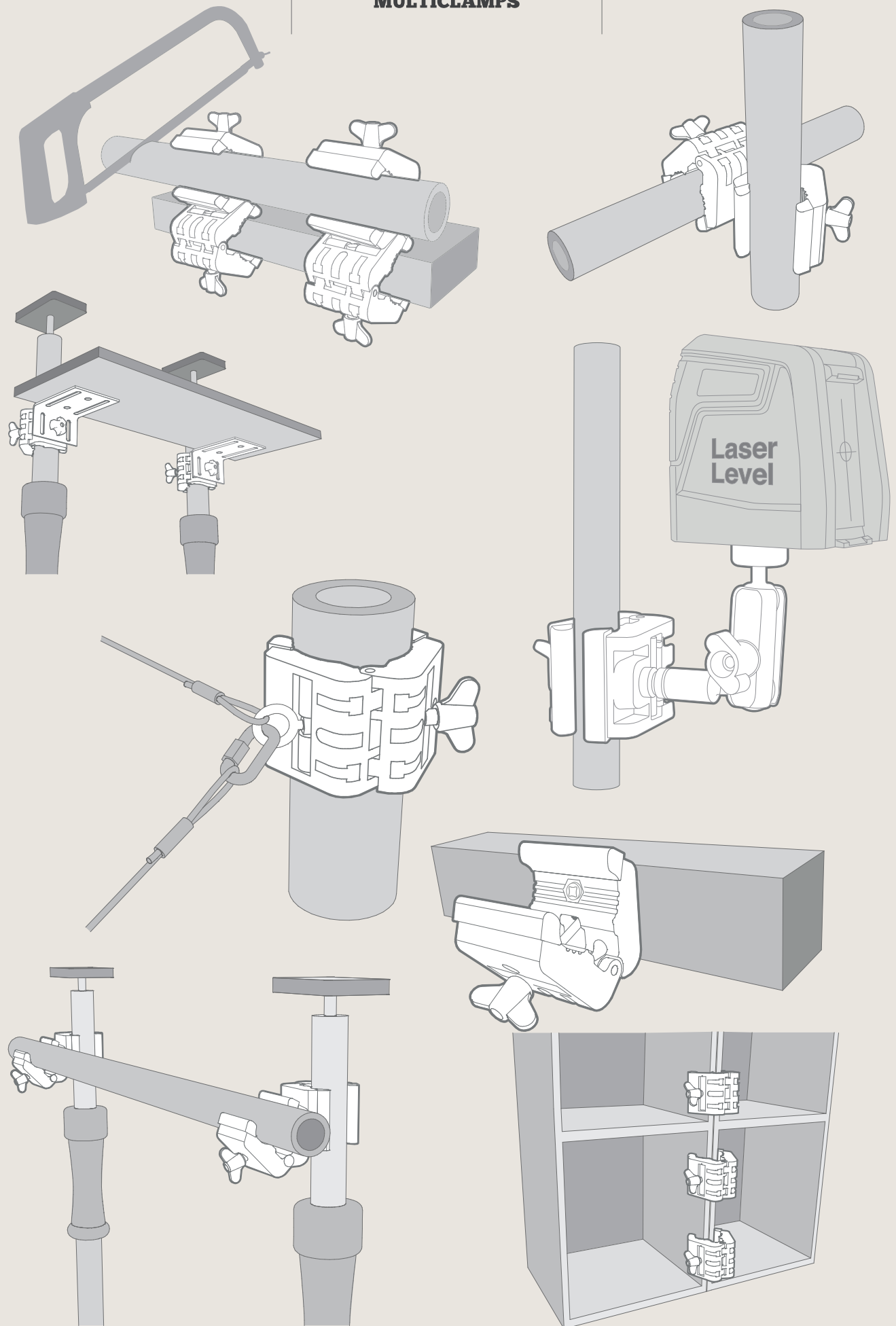



**MULTICLAMP**  
MULTICLAMP



COD	mm	mm	Kg	
34052	50	18-48	0.22	1



**MULTICLAMP CON GANCHO**  
MULTICLAMP WITH HOOK



COD	mm	mm	Kg	
34044	40	18-40	0.23	1



**MULTICLAMP CON ARGOLLA**  
MULTICLAMP WITH PRESSED EYE



COD	mm	mm	Kg	
34046	40	18-48	0.23	1



**MULTICLAMP CON BASE REGULABLE** · MULTICLAMP WITH ADJUSTABLE BASE



COD	mm	mm	Kg	
34048	50	18-48	0.38	1

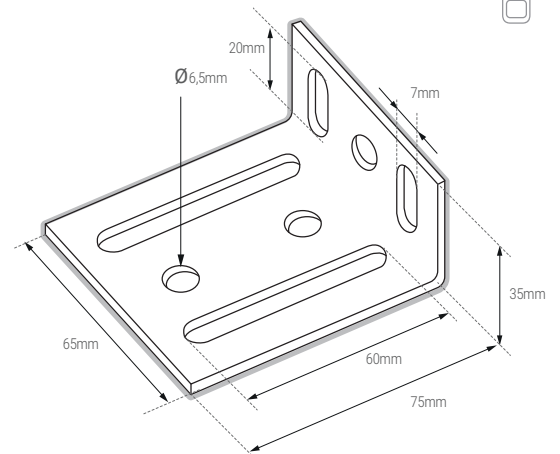



**MULTICLAMP DOBLE FIJA** • FIXED DOUBLE MULTICLAMP •

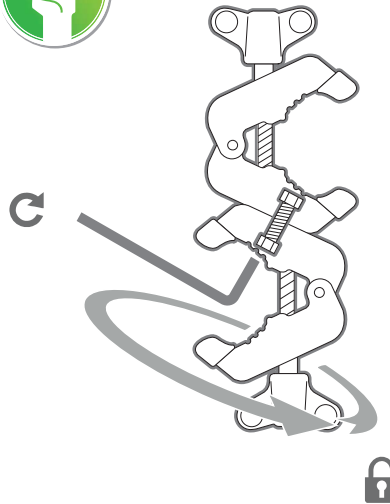

COD	mm	mm	Kg	
34054	50	18-48	0.44	1

- Dos piezas Multiclamps unidas por tornillo M6 con ángulo ajustable fijo de 360° tensando el tornillo M6 para bloquear las coronas dentadas plásticas y fijar la posición.
- *Two Multiclamps connected using an M6 screw with an adjustable fixed 360° angle tightening the M6 screw.*

**MULTICLAMP DOBLE PIVOTANTE** • PIVOTING DOUBLE MULTICLAMP •

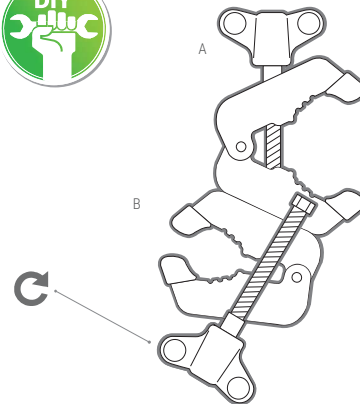

COD	mm	mm	Kg	
34055	A: 50	A: 18-48	0.44	1
	B: 30	B: 18-30		

- Dos piezas Multiclamps unidas por el eje roscado de la pieza pivotante y con ángulo ajustable de 360°
- Al tensar la palomilla de la pieza pivotante puede modificarse fácilmente su presión y su ángulo, dejándolo semi bloqueado.
- *Two Multiclamps connected through the threaded shaft of the pivoting clamp and with an adjustable 360° angle.*
- *By turning up the wing nut you can easily adjust the pressure and the angle semi-locking it.*

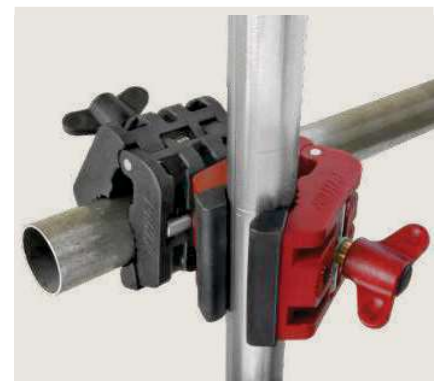



**SOPORTE MULTI-DISPOSITIVOS · MULTI-DEVICE SUPPORT**

**NEW**



COD	mm	mm	Kg	1
34061	50	18-48	0.42	1

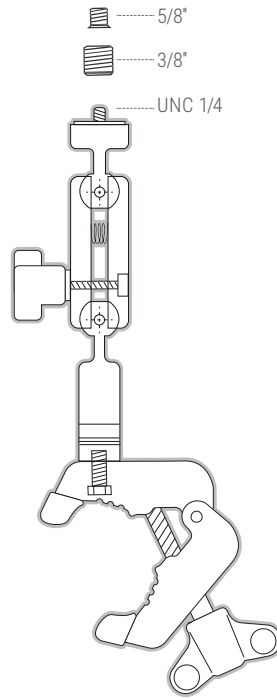

- Construcción en aluminio.
- Multi-posición con dos articulaciones.
- Fijación rápida.
- Rosca UNC 1/4 y adaptadores 3/8 y 5/8 incluidos
- Fuerza de soporte 3Kg (6,61 lbs).
- Para lasers, camaras, niveles, etc.

- Made of aluminium
- Multi-positionable with two joints.
- Easily fixed.
- UNC 1/4 Thread
- 3/8 y 5/8 Thread Adaptor
- Holding capacity 3Kg (6,61 lbs)..
- For lasers, cameras, levels, etc.

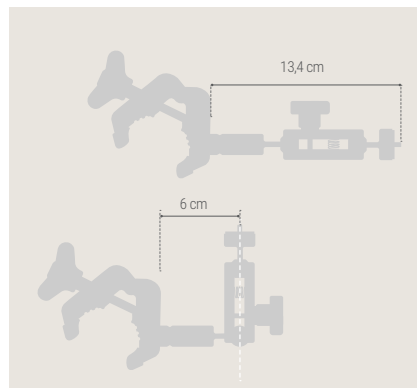

**AL** Fabricado en aluminio.  
Made of Aluminium.

**NEW**

**ADAPTADOR RÁPIDO UNC 1/4 · QUICK ADAPTOR UNC 1/4**



- Fabricados en aluminio.
- Con tornillo estándar UNC 1/4
- Made of aluminium.
- Standard UNC 1/4 screw

COD	Kg	1
34064	0,031	1



**\* SET ADAPTADORES DE ROSCA · THREAD ADAPTOR KIT**



- Fabricados en latón para evitar daños en el dispositivo.
- Made of brass to avoid damage to the device.

COD	Kg	1
34059	0,025	1

2 unit-pack



## MULTICLAMPS

### SOPORTE MULTI DISPOSITIVOS CON VENTOSA MULTI-DEVICE SUPPORT WITH SUCTION CUP

NEW

- Protector incluido.
- 25Kg de capacidad de succión horizontal.
- Adapador de rosca incluidos
- Protection cap included.
- Horizontal suction capacity 25Kg
- Thread adaptors included

COD	Øcm	Kg	☐
34058	11,5	0,72	1



### SOPORTE MULTI DISPOSITIVOS CON IMÁN MULTI-DEVICE SUPPORT WITH MAGNET

NEW

- Potente iman de ferrita permanente.
- Adapador de rosca incluidos
- Powerful permanent ferrite magnet.
- Thread adaptors included

COD	Øcm	Kg	☐
34063	8,8	0,62	1



### SOPORTE PARA TABLETAS Y MOVILES • SMARTPHONE & TABLET HOLDER

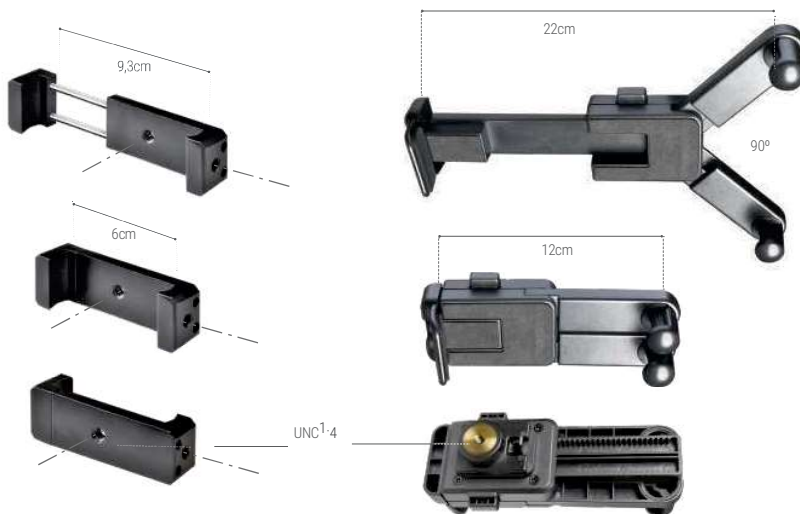

**AL** Hecho en Aluminio  
Made in Aluminium

COD	Kg	☐
34056	0,038	1

Fabricado en plástico ABS  
Made of ABS Plastic.

COD	Kg	☐
34057	0,15	1

- Para el Soporte Multi-dispositivos.
- Superficies de contacto protegidas con goma
- Multi-device Support accesories.
- Rubber protected contact surfaces.



### CAJAS EXPOSITORA MULTICLAMP • MULTICLAMP DISPLAY BOX



COD	SET	Kg	☐
34072	34052x8	5,2	1
	34044x4		
	34046x4		
34071	34052x4	5,38	1
	34044x4		
	34061x4		