



NEW

MAXI QUICK 300



300 kg		20x5 mm			
COD	cm	cm	Kg	R cm	
52691	15	9,4	1,1	22-42	6
52692	30		1,21	22-57	
52693	45		1,32	22-72	
52694	60		1,43	22-87	
52695	90		1,65	22-117	
52696	125		1,9	22-152	

- Sistema de fijación patentado Easy Grip:
- Más presión con menos esfuerzo.
- Zapatas antideslizantes extra largas.
- Liberación progresiva en dos pasos.

- Easy grip patented system: more pressure with less effort.
- Extra-large non-slip pad.
- Progressive two step release.

SET PROTECTOR · PROTECTION CAP SET



COD	Kg	
52682	0,05	2



QUICK PIHER

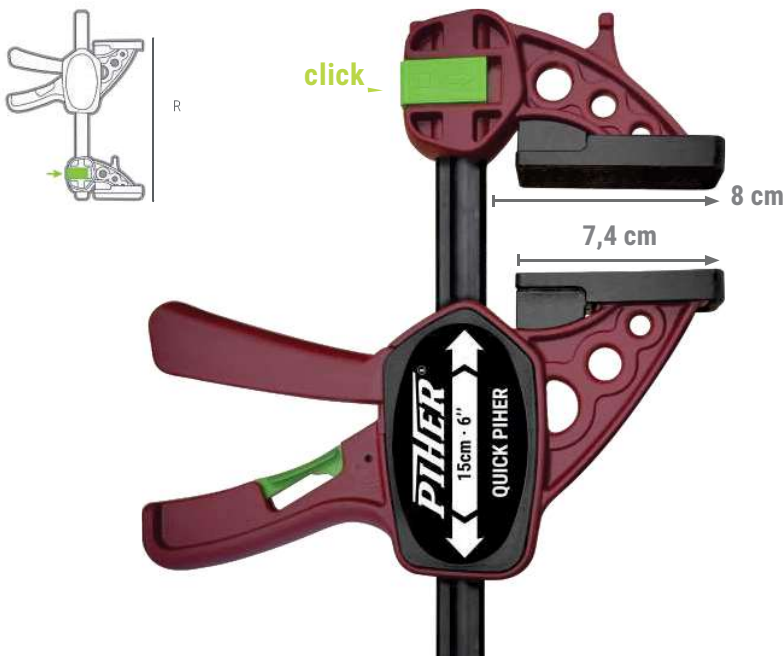

150 kg		19x6,3 mm			
COD	cm	cm	Kg	R cm	
52615	15	8	0,65	17.5-32.5	5
52630	30		0,76	17.5-47.5	
52645	45		0,88	17.5-49.0	
52660	60		1,00	17.5-77.5	
52690	90		1,24	17.5-107.5	
52625	125		1,74	17.5-142.5	

SET PROTECTOR · PROTECTION CAP SET



COD	cm	Kg	
52501	7,4	0,05	2
52505	5		



# QUICKS

## MINI QUICK



75 kg		13,9x4,4 mm				
COD	cm	cm	cm	Kg	R cm	
52415	15	6	32	0,27	12.5-27	10
52430	30	6	47	0,34	12.5-42	

## MICRO QUICK



25 kg		8X3 mm				
COD	cm	cm	cm	gr	R cm	
52015	10	4	19	140	7.5-17.5	4
52016	20	4	29	200	7.5-27.5	

## T-TRACK QUICK



60 kg		13,9x4,4 mm		
COD	cm	cm	Kg	
52101	15	7	0,25	10
52103	22	7	0,29	

### SET PROTECTOR PROTECTION CAPS



COD	Kg	
52412	0,04	2



2 units blister

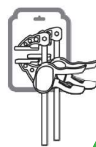

### PROTECTOR · PROTECTION CAPS



COD	
52017	1



### PROTECTOR · PROTECTION CAPS



COD	Kg	
52098	0,01	1



### CAJA DE 16 MINI QUICK PIHER DE 15cm BOX OF 16 PIECES OF 15cm MINI QUICK PIHER

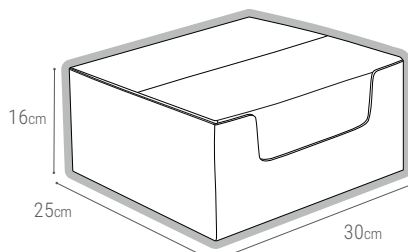

COD	Kg	
52414	4,8	1

COD 52414 x16

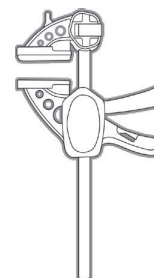

NEW

TCM - PARA MESAS DE ORIFICIOS · TCM - WOODWORKING HOLE TABLE

DISEÑO Y FABRICACIÓN PROPIA  
OWN MAKE & DESIGN MADE IN SPAIN



COD	Kg	📦
19130	0,16	1

Hecho en acero. *Made of Steel.*  
Para modelos *For our models:*

Mini Quick

Doble función horizontal y vertical, para mesas con orificios de 19 o 20 mm y máximo espesor de 26 mm.

*Double horizontal and vertical function, for tables with 19 or 20 mm holes and a maximum thickness of 26 mm.*

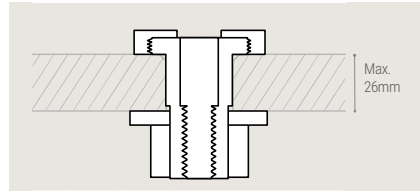

UNIÓN DE BARRAS DE QUICKS · QUICK BAR EXTENSION

DISEÑO Y FABRICACIÓN PROPIA  
OWN MAKE & DESIGN MADE IN SPAIN



COD	Kg	📦
52506	0,15	1

Hecho en acero. *Made of Steel.*  
Para modelos *For our models:*

Maxi Quick   Quick   Mini Quick

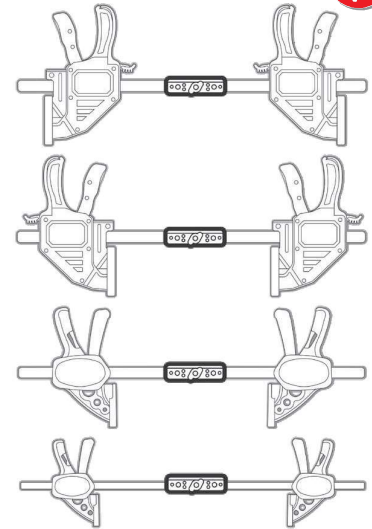

SET DE ACCESORIO PARA TARIMAS · DECK CLAMP ACCESSORY



COD	Kg	📦
30167	0.14	1

Para modelos *For our models:*

Quick

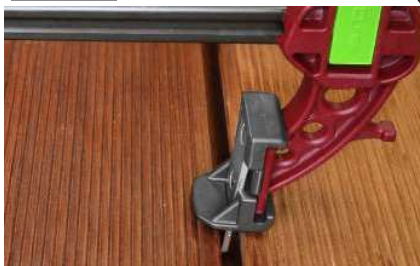

Zapata especial para la instalación de tarima y trabajos en espacios estrechos. Soporte de PA y puntos de presión de acero.

*Special cap for decks & wooden platforms and work in narrow spaces. Polyamide caps with steel plates.*

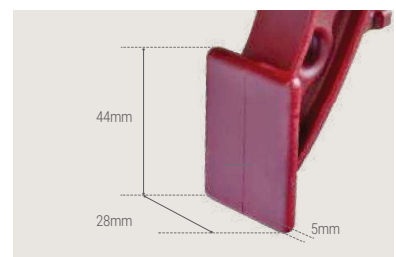

# APRIETOS DE PALANCA RATCHET CLAMPS

## LIGHT PAL



- Mordaza ligeras de nylon y fibra de vidrio
- Llantita cincada de 20x5 mm
- Reversible
- Frenos y ejes de acero.

- Nylon and fibreglass jaws.
- Zinc coated 20x5 mm bar
- Reversible
- Two steel brake plates



Protectores TPR en las mordaza fija y móvil.

TPR Protection caps on both jaws.

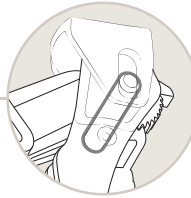
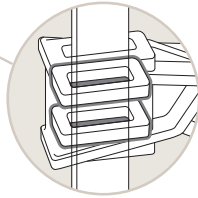

	120 kg	20x5 mm			
COD	cm	cm	cm	Kg	R cm
30901	16	8	6	0,47	13-34
30903	30			0,55	13-48



Dos pletinas de frenos y eje de acero.  
Two steel brake plates and steel axes.



### CAJA DE 16 LIGHT PAL DE 16cm • BOX OF 16 PIECES OF 16cm LIGHT PAL CLAMPS

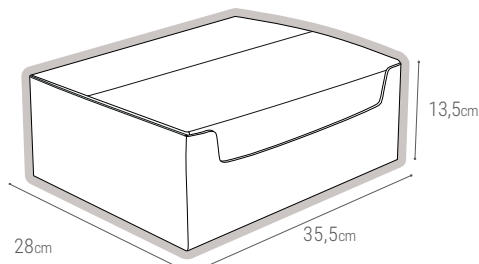

COD	Kg	☐
30900	7,5	1

COD 30901 x16



# APRIETOS DE PALANCA RATCHET CLAMPS

## QUICK PAL ALUMINIO



- Mordazas y palanca de aluminio
- Sistema de carraca de acero
- Barra de acero al carbono Protectores con sistema de antiperdida en las dos mordazas
- Liberación de presión fácil

- *Aluminum jaws and lever*
- *Steel ratchet system*
- *Carbon steel bar*
- *Protection caps with loss prevention system on both jaws*
- *Just one click pressure release*

	🌀 250 kg	▨ 19x6,3 mm			
COD	cm	cm	cm	Kg	📦
30820	15	8	6	0,6	10
30821	30			0,71	

### SET PROTECTORES · PROTECTION CAPS



COD	Kg	📦
30819	0,03	2



## MOD. MADERA · WOODEN CLAMPS

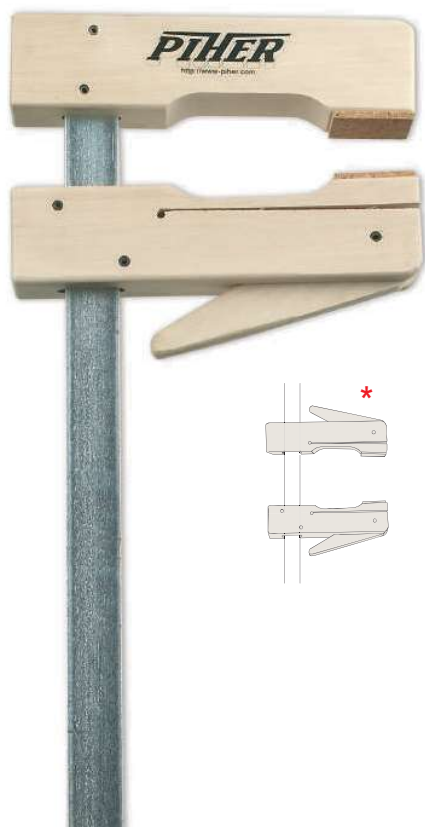

- Llantas de acero zincada.
- Sistema de freno anti-deslizante.
- Protectores de corcho que evita marcas de presión.
- Particularmente robusto, en madera de haya blanca.
- De fácil manejo y cómodo transporte debido a su escaso peso.
- *Zinc coated steel bar.*
- *Non-slip brake on moving jaw.*
- *Cork protectors prevent pressure marks.*
- *Really strong, top quality beech wood.*
- *Easy to use and carry, it's so light.*

	🌀 50 kg	▨ 20x5 mm			
COD	cm	cm	Kg	📦	
25020	20	11	0,43	10	
25030	30	11	0,51		
25040	40	11	0,60		
25060	60	11	0,74		
25080	80	11	0,93		
25100 *	100	11	1,20		
25120 *	120	11	1,27		
25150	20	15	0,50		
25200	20	20	0,55		

### PROTECTOR EXTENSOR EXTRA LARGE PROTECTOR

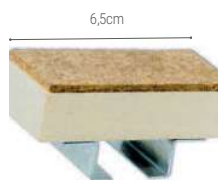

COD	Kg	📦
25006	0,02	1

### APLACACANTOS EDGE-GRIP PIECE



COD	cm	Kg	📦
25001	11	0,10	1

# PARA GUÍAS Y ORIFICIOS FOR HOLES & GUIDES

MOD. TMM

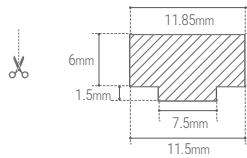

150 kg

13,5x6,5 mm

COD	cm	cm	Kg	
30800	12	6	0,3	10
30801	16	6	0,33	
30802	20	6	0,35	
30803	30	6	0,36	

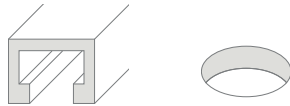

BRIDA GC · GC CLAMPS



Chapa estampada  
Stamped sheet metal

COD	MOD	cm	cm	Kg	
07004	GC-3	3	2,5	0,07	10
07005	GC-5	5	3	0,1	
07007	GC-7	7	7	0,3	

MOD. TPAL

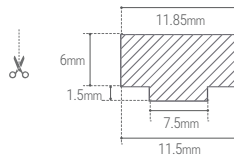

150 kg

13,5x6,5 mm

COD	cm	cm	Kg	
30810	12	6	0,5	10
30811	16	6	0,53	
30812	20	6	0,55	
30813	30	6	0,6	

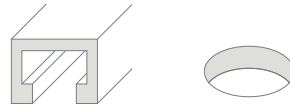

BRIDA DE MARQUETERÍA · G WOODWORKING CLAMPS



Cuerpo fabricado en pletina de 16x6  
Steel bar 16x6 body

COD	MOD	cm	cm	Kg	
55030	3	3	2,8	0,14	10
55050	5	4,5	3,2	0,16	
55070	7	7	3,8	0,2	
55010	10	9,5	4,2	0,23	

T-TRACK QUICK

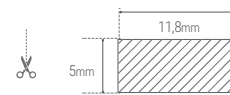

60 kg

13,9x4,4 mm

COD	cm	cm	Kg	
52101	15	7	0,25	10
52103	22	7	0,29	

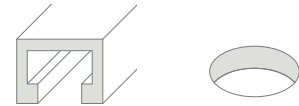

G TABLE CLAMP · G DE MESA



COD	Kg	
55430	0,14	10

Cuerpo fabricado en aleación de aluminio.  
Husillo y barra de presión de acero.





Body made of aluminum alloy.  
Spindle and pressure bar made of steel.



## PINZAS SPRING CLAMPS

### PINZA REGULABLE ADJUSTABLE SPRING CLAMP



COD	 cm	 cm	 cm	kg		
30910	3	3,5	11,5	0,08	<b>0-20 Kg</b>	40
30911	5	6	16,5	0,13	<b>0- 18 Kg</b>	25

- Cuerpo de nylon y fibra de vidrio.
- Mordazas de PE de ángulo variable.
- Muelle templado extrafuerte.



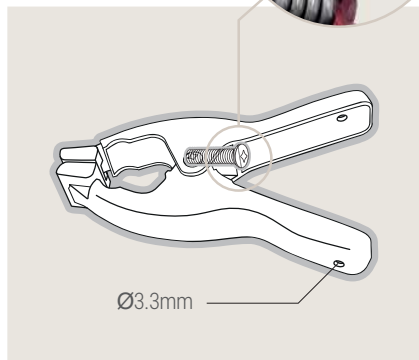

- *Nylon and fibreglass body.*
- *Adjustable angle grips.*
- *Extra-resistant tempered spring.*

Fuerza de presión regulable mediante tornillo.  
*Adjustable screw pressure.*



### PINZA PROFESIONAL METÁLICA PROFESSIONAL METAL SPRING CLAMP



COD	 cm	 cm	 cm	kg	
30007	3,5	3	11	0,08	20
30008	5,5	4,5	16	0,17	10
30009	8,5	7	24	0,40	40



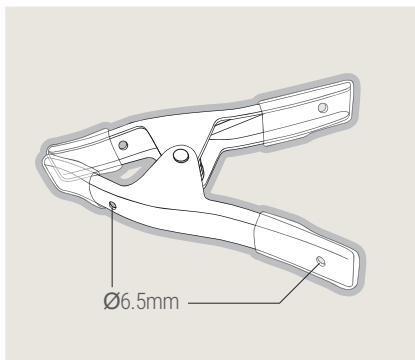

- Recubrimiento antioxidante de cataforesis, más resistente y respetuoso con el medio ambiente.
- Cuerpo de acero.
- Protectores de PVC en puntas y mangos.
- Muelle templado extrafuerte.
- Doble orificio en cada asa.

- *Cataphoresis antioxidant coating, more resistant and respectful with the environment.*
- *Steel body.*
- *PVC protection on grip ends and handles.*
- *Extra resistant tempered spring.*
- *Double hole in each handle.*



### PINZA METÁLICA METAL SPRING CLAMP



COD	 cm	 cm	 cm	kg	
57025	2,5	3	11	0,05	24
57050	5	5	16	0,16	20

- Cuerpo de acero.
- Protectores de plástico en puntas.
- Muelle de media carga.

- *Steel body.*
- *Plastic protection on grip ends.*
- *Medium-load spring.*

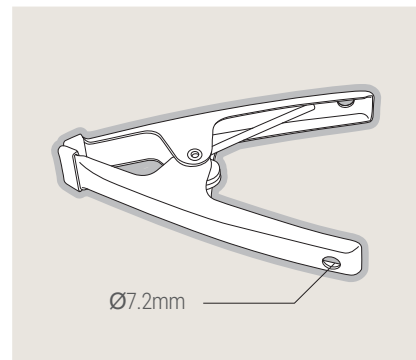



## PINZAS PROGRESIVAS PROGRESSIVE PRESSURE CLAMPS

### PINZAS EXTENSIBLE • EXTENDABLE PROGRESSIVE PRESSURE CLAMP



COD	cm	cm	cm	kg	
52204	16	6	21	0,23	10



Mordazas de PE sin aceites. No deja huella.  
Oil free PE plastic grips. Stain-free.

- Mordazas blandas de ángulo variable.
- Cuerpo fabricado de Nylon con fibra de vidrio.
- Mango de agarre ergonómico y antideslizante.
- Fácil de liberar con un solo dedo.

- Adjustable angle grips.
- Nylon fibreglass body.
- Comfortable non-slip handle.
- Easy single finger pressure release.

### PINZAS DE PRESIÓN PROGRESIVA • PROGRESSIVE PRESSURE CLAMPS



COD. 52201

COD	cm	cm	cm	kg	
52201	5,5	4	18	0,16	10
52202	8,5	7,5	22	0,20	
52203	8,5	8,5	22	0,18	

- Mordazas blandas de ángulo variable.
- Cuerpo fabricado de Nylon con fibra de vidrio.
- Mango de agarre ergonómico y antideslizante.
- Fácil de liberar con un solo dedo.

- Adjustable angle grips.
- Nylon fibreglass body.
- Comfortable non-slip handle.
- Easy single finger pressure release.



Mordazas de PE sin aceites. No deja huella.  
Oil free PE plastic grips. Stain-free.

COD. 52203

# PRENSA DE FLEJE DE ACERO STEEL BAND CLAMP

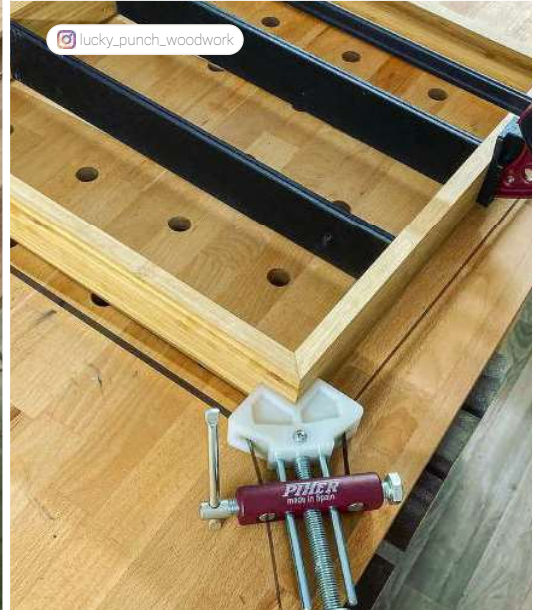
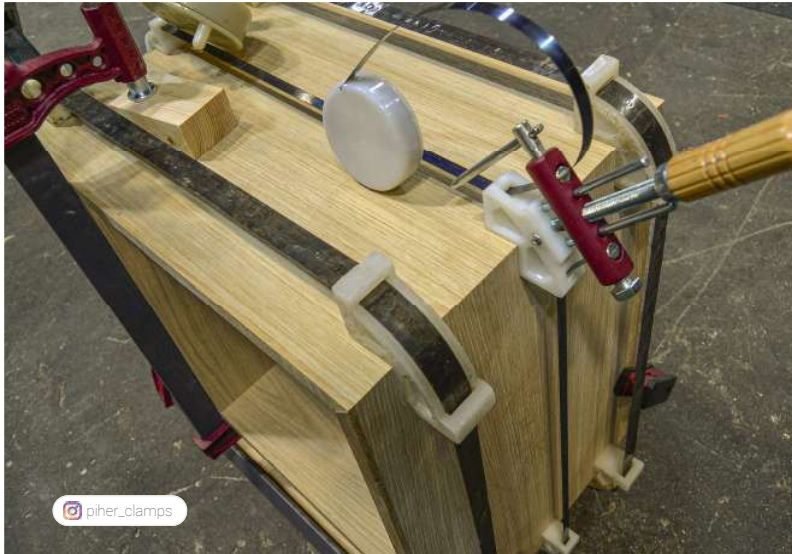

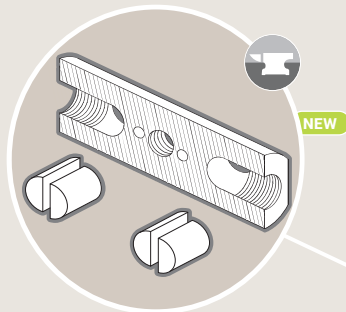

Conjunto base y frenos de acero.  
*Steel base unit and brakes.*



Ángulos de nylon a 89°.  
*Nylon angle grips.*

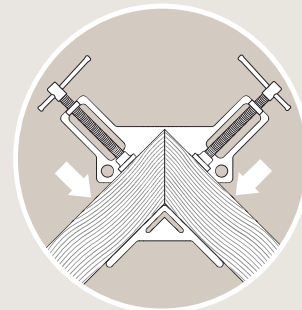

Así asegurar un perfecto escuadrado en todas las esquinas, incluso cuando los ingleses tienen algún fallo en el ángulo.

*Thus ensuring perfect right angles at all the corners, even when the mitre joints have slightly incorrect angles.*

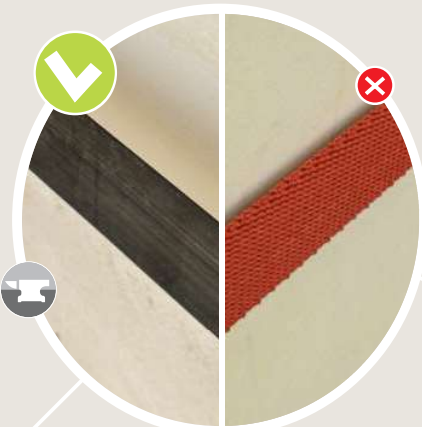

Fleje de acero extrafuerte de acero laminado templado CK67S  
*Extra resistant tempered steel band CK67S.*

Al no ser fleje de tejido no se destiende y el apriete se mantiene constante.  
*As it is not a cloth strap, it does not untwist and the tightness remains constant.*



Cantos del fleje no cortantes para mayor seguridad.  
*Smooth steel band edges.*



NEW



Mango antideslizante de madera de haya.

*Non-slip beech wood handle*





**MOD. A, B Y C RECTÁNGULO · RECTANGULAR MODELS**

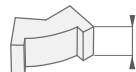
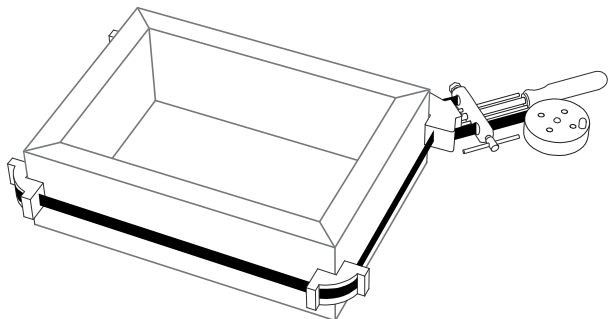

COD	MOD	Largo · Length cm	Fleje · Band mm	L cm	Kg	
24002	A	500	12 x 0,35	2,8	1,29	1
24003	B	650	20 x 0,35	3,1	2,09	
24004	C	800	25 x 0,35	4	2,71	

**MOD. B Y C AROS · STEEL BAND RING MODELS**

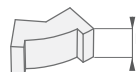
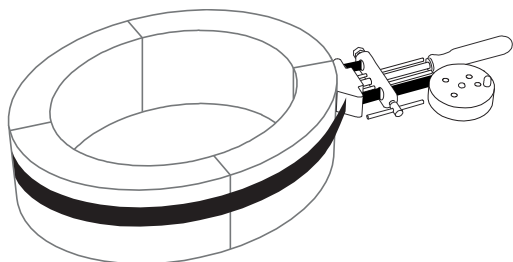

COD	MOD	Largo · Length cm	Fleje · Band mm	L cm	Kg	
24005	B (aros)	650	20 x 0,35	3,1	1,79	1
24006	C (aros)	800	25 x 0,35	4	2,37	

**MOD. HEXAGONAL · HEXAGONAL MODEL**

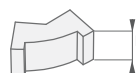
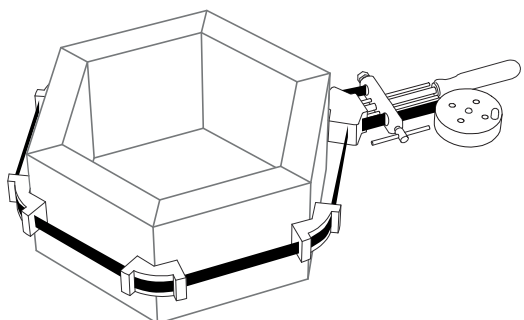

COD	MOD	Largo · Length cm	Fleje · Band mm	L cm	Kg	
24007	A Hex.	500	12 x 0,35	2,8	1,31	1

**MOD. OCTOGONAL · OCTOGONAL MODEL**

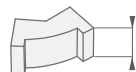
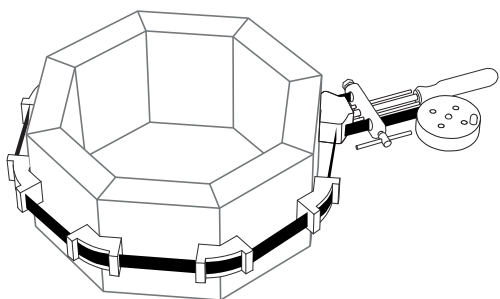

COD	MOD	Largo · Length cm	Fleje · Band mm	L cm	Kg	
24008	A Oct.	500	12 x 0,35	2,8	1,45	1

**REPUESTOS · SPARES**

COD	MOD	
24011	Ángulo Nylon A <i>Nylon angle</i>	
24012	Ángulo Nylon B <i>Nylon angle</i>	
24013	Ángulo Nylon C <i>Nylon angle</i>	
24015	Fleje con carcasa A <i>Nylon Reel</i>	
24016	Fleje con carcasa B <i>Nylon Reel</i>	
24017	Fleje con carcasa C <i>Nylon Reel</i>	

COD	MOD	
24021	Ángulo base Nylon A <i>Base angle</i>	
24022	Ángulo base Nylon B <i>Base angle</i>	
24023	Ángulo base Nylon C <i>Base angle</i>	
24511	Conjunto base de acero A <i>Steel Base unit</i>	
24512	Conjunto base de acero B <i>Steel Base unit</i>	
24513	Conjunto base de acero C <i>Steel Base unit</i>	

## PRENSA DE CINTA STRAP CLAMPS

### PRENSA DE CINTA PARA TARIMA CLAMPING STRAPS FOR PARQUET



- Hasta 800 Kg. de resistencia.
- Cinta de nylon de 5 m.
- *Up to 800kg. resistance.*
- *Nylon Strap: 5 m. in length.*

COD	Kg	📦
30014	0,89	1

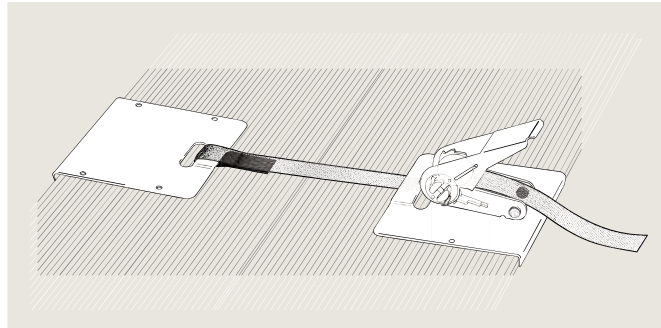

### PRENSA DE CINTA MULTIUSOS HOLD-ALL STRAP CLAMP



- Hasta 800 Kg. de presión.
- Cuatro ángulos metálicos para formas cuadradas y rectangulares.
- Protectores de cantos P.E.A.D.
- Cinta de nylon de 5 m.

COD	Kg	📦
30013	0,49	1

- *For loads up to 800 Kg.*
- *Metal right-angled corner pieces.*
- *H.D.P.E. corner protection pads.*
- *Nylon strap: 5 m. in length.*

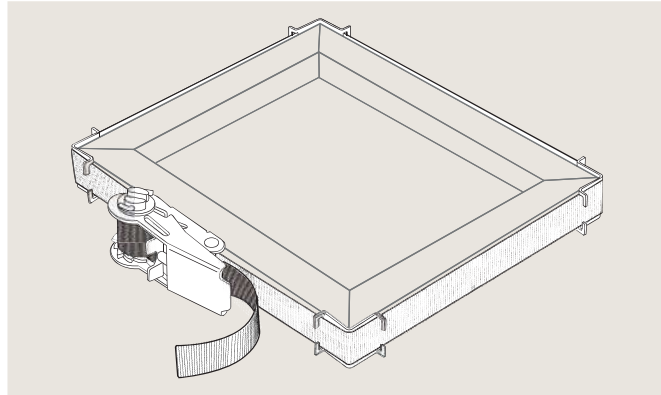

### MOD. G 3T

NEW



- Cuerpo fundición nodular
- Husillos de acero cincados
- Con protectores PE
- Para la sujeción de cantos.

COD	📏 cm	📏 cm	gr	📦
55400	6	6,5	500	20

- *Nodular cast iron body.*
- *Zinc plated threaded screw*
- *PE plastic protection cap included*
- *For edge-grip clamping*

# APLACACANTOS EDGE-GRIP SCREWS

## MOD. APLACACANTOS SENCILLO Y DOBLE · DOUBLE & SINGLE EDGE-GRIP SCREWS



- Cuerpo de acero
  - Husillos de acero cincados
  - Mango de haya
  - Con protector PE
- *Steel body.*
  - *Zinc plated threaded screw*
  - *Beech wood handle*
  - *PE plastic protection cap included*

COD	Kg	
19000	0.15	1



DISEÑO Y FABRICACIÓN PROPIA  
OWN MAKE & DESIGN MADE IN SPAIN

COD	Kg	
19003	0.32	1



Adaptable a todos los modelos.  
Fits all models.



## MORDAZA DE MONTAJE Y APLACACANTOS · EDGE GRIP & ASSEMBLY CLAMP

NEW

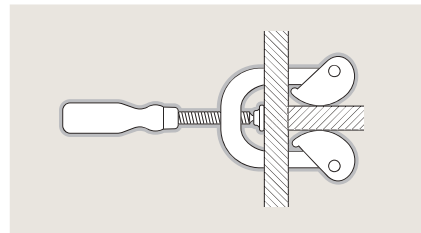
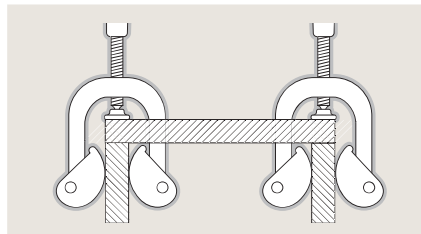
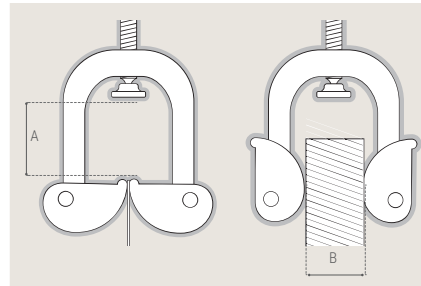

COD	A mm min-Max	B mm min-Max	Kg	
57099	30-50	1-4,5	0,73	1
57100	40-70	1-6,5	1,8	1

- Para colocar juntas y ángulos perfectamente y con precisión.
- Nuevo diseño más ergonómico.
- Fácil de usar con una sola mano.
- Cuerpo, husillo y tuerca de acero.
- Mango de madera de haya.
- Mordazas de PP con TPR antideslizante.

- *Angle and joints can be positioned perfectly and fitted accurately*
- *Modern design ergonomically shaped.*
- *Easy single hand use.*
- *Steel body, spindle and nut.*
- *Beech wood handle.*
- *PP jaws with non-slip TPR.*

### REPUESTO · SPARE PARTS



COD	Mod	Kg	
57107	57099	0,3	1
57108	57100	0,2	

Incluida la tornillería de montaje.  
Assembling hardware included.

# PARA SIERRAS DE MESA, DE BANDA Y FRESADORAS FOR TABLE SAWS, BAND SAWS & ROUTERS

## FP1 PLUMA PRO · FP1 FEATHERPRO



COD	Kg	📦
63100	0,45	1

Fijaciones incluidas para:  
Fit options included for:



19mm  
20mm  
3/4"

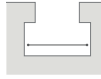

12mm  
18mm  
1/2"-3/4"

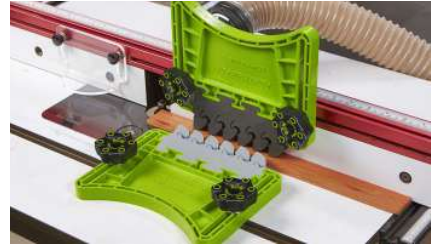

- Seguridad y precisión
- Absorbe vibraciones para cortes más limpios.
- Deslizamiento suave bajo altas tensiones.
- Diseño exclusivo de bisagra flexible que bloquea cualquier contragolpe de la pieza de corte.
- Contacto de goma EVA de alta densidad reversible y reemplazable.
- Cuerpo de PA con fibra de vidrio.

- *Safety and precision*
- *Absorbs vibration for a cleaner cut.*
- *Smooth glide under high tension, non marring.*
- *Anti-Kickback living hinge in feather design. Absorbs energy as hinge closes and helps mitigate any kickback.*
- *High-Density EVA foam feather: reversible and replaceable*
- *Long lasting wear resistant PA body.*

## FP3 PLUMA DUO · FP3 FEATHERDUO



COD	Kg	📦
63101	1,08	1

Fijaciones incluidas:  
Fit options included:

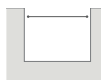

19mm  
20mm  
3/4"

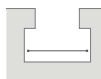

12mm  
18mm  
1/2"-3/4"



- Incluye el material para dos FP1 PRO individuales
- Especial para piezas altas en sierras de mesa, de banda y fresadoras.
- Alcanza una altura de 9 cm.
- Cuerpo de PA con fibra de vidrio.
- Incluye las mismas opciones de fijación que la FP1 para perfiles standar y perfiles T.

- *Includes hardware for two individual FeatherPRO Featherboards*
- *Ideal for taller material on table saws, band saws and router tables.*
- *9cm height reaches.*
- *Long lasting wear resistant PA body.*
- *FeatherPRO fit options included for standard tracks and T-tracks*

### SET DE REPUESTOS · REPLACEMENT SET



**FPS2** Standard

COD	Kg	📦
63102	0,14	2

Para todo tipo de material  
*For all types of material*



**FPU2** Ultralight

COD	Kg	📦
63103	0,14	2

Especial sensibilidad de presión para cortes delicados o piezas pequeñas  
*Exceptional pressure sensitivity for delicate cuts and small pieces*



# PARA SIERRAS DE MESA, DE BANDA Y FRESADORAS FOR TABLE SAWS, BAND SAWS & ROUTERS

## GP5 GUÍA PRO · GP5 GUIDEPRO



COD	Kg	📦
63104	0,8	1

Fijaciones incluidas para:  
Fit options included for:

19-20mm 3/4"



16mm 5/8"



15mm 3/4"



- Para sierra de cinta
- Superficie de silicona aplica presión constante en el extremo vertical de la pieza de corte.
- Flexible a las variaciones de grosor de la pieza.
- Absorbe la vibración para un corte limpio.
- Protege las manos durante la alimentación de la sierra aumentando la seguridad
- Fácil de montar

- For bandsaws.
- Durable silicone feather applies constant and consistent pressure along the vertical edge of the workpiece.
- Flexible feather accommodates variations in workpiece.
- Absorbs vibration for a cleaner cut.
- Shields hands behind GuidePRO during saw feed.
- Fast set up.

## ANCLAJE GP9 · GUIDEPRO ANCHOR BAR

COD	Kg	📦
63106	0,55	1



19mm  
20mm  
3/4"

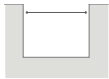

Fija la GP5 a perfiles. Extiende su uso a sierras y fresadoras de mesa.

Locks GuidePRO into Mitre Slot.  
Extends use of the GuidePRO to the router or table saw.

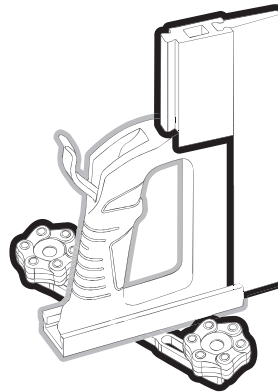

## EXTENSIÓN GP7 · GP7 GUIDEPRO EXTENSION

COD	Kg	📦
63105	0,32	1



25cm



Amplia la longitud de la pluma de silicona hasta los 25 cm. Especial para paneles.

Expand the silicone feather height up to 25cm (10"). Ideal for taller panel feeds.

## PUSHPRO PUSH STICK PP1 · PP1

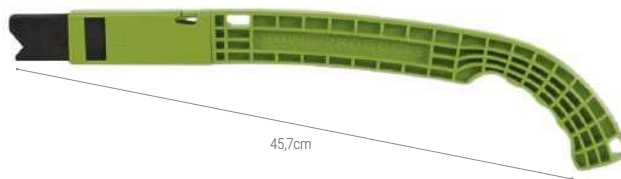

45,7cm

COD	Kg	📦
63107	0,32	1



- Bastón ergonómico en PA con fibra de vidrio para controlar el deslizamiento seguro de piezas de corte.
- Zapata recambiable de doble posición, de goma EVA de alta densidad.
- Módulo de la zapata acoplable a mangos personalizados.

- Ergonomic PA with Fibreglass push stick for comfortable and safety feed control.
- High-density EVA foam pad: replaceable with two positions
- Modular construction: custom made handle which can be mounted to the coupler



## REPUESTO PPR1 REPLACEMENT PADS PPR1

COD	Kg	📦
63108	0,1	1





**PARA SIERRAS DE MESA, DE BANDA Y FRESADORAS  
FOR TABLE SAWS, BAND SAWS & ROUTERS**

FP4

NEW

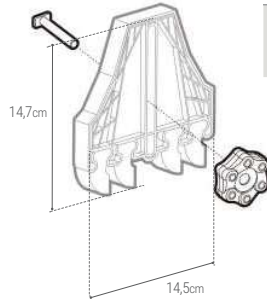

COD	Kg	📦
63109	0,4	1

Fijaciones incluidas para:  
Fit options included for:

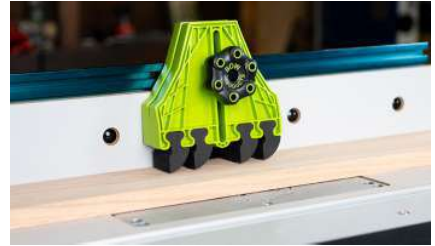

FP5 PLUMA PORTÁTIL · FP5 PORTABLE FEATHER

NEW

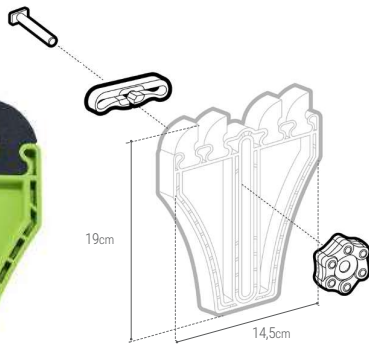

COD	Kg	📦
63110	0,3	1

Fijaciones incluidas para:  
Fit options included for:

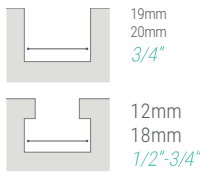

RF45

4 unidades · 4 units



Plumas de Repuesto para FP4 y FP5  
FP4 & FP5 Replacement Feathers

COD	Kg	📦
63111	0,1	1

AP1



para guías de 3/4"  
for 3/4" mitre bar

COD	Kg	📦
63112	0,32	1

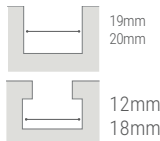

AP3



para guías de 3/4"  
for 3/4" mitre bar

COD	Kg	📦
63114	0,61	1

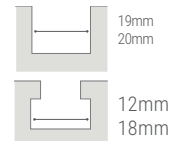

**PARA SIERRAS DE MESA, DE BANDA Y FRESADORAS  
FOR TABLE SAWS, BAND SAWS & ROUTERS**

BM 1824

NEW

COD	Kg	
63117	0,23	1



- Alfombra de uso general de 45x61cm
- Material TPA de 2 capas
- Agarra y estabiliza materiales y herramientas
- Ideal para trabajos delicados, seguimiento de piezas pequeñas y mantenimiento de herramientas

- 18" X 24" General Purpose Mat.
- 2 layer TPA material.
- Grips and Stabilizes Materials and Tools.
- Ideal for Delicate Work, Keeping Track of Small Pieces, and Tool Maintenance



B123

NEW

COD	Kg	
63118	0,26	1



- Bloques de EVA de uso general prácticos para una multitud de aplicaciones de soporte o de corte.
- Utilícelos individualmente o en conjunto para necesidades de profundidad o altura.
- Tres cuadros de 15cm de lado (con grosores de 2,5, 5 y 7,6cm)

- General Purpose EVA Blocks Are Handy For A Multitude Of Support Or Cut Through Applications.
- Use Individually Or Together For Depths Or Height Needs
- Contains Three 6" Square Blocks; (1", 2" and 3" thick)



**AP2 - KIT PARA GUIAS DE 3/4"**  
AP2 - 3/4" MITRE BAR KIT



para guías de 3/4"  
for 3/4" mitre bar

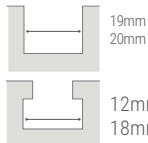

COD	Kg	
63113	0,22	1

**AP4 - KIT PARA GUIAS DE 5/8"**  
AP4 - 5/8" MITRE BAR KIT



para guías de 5/8"  
for 5/8" mitre bar

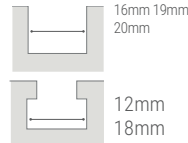

COD	Kg	
63115	0,21	1

**KNB4**



COD	Kg	
63116	0,18	1

## MORDAZAS DE ÁNGULO ANGLE CLAMPS

### MORDAZA DE ÁNGULO PARA MONTAJE · ANGLE CLAMPS FOR MOUNTING WORK



- Mordazas de aleación de aluminio, husillo de acero y partes plásticas de nylon.
- *Aluminum alloy jaws, steel spindle and nylon plastic parts.*

**AL** Hecho en Aluminio  
Made in Aluminium

COD	MOD	A cm	B cm	C cm	Kg	
30003	A-30	0-8	2,7	3	1,05	1

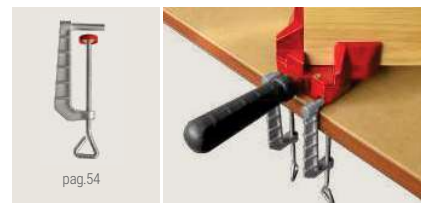

Autoajutable a diferentes espesores.

Self adjustable to different thicknesses.

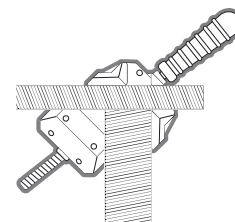

### MORDAZA DE ÁNGULO PARA MADERA · WOOD WORKING ANGLE CLAMPS



- Mordazas de aleación de aluminio y husillo de acero.
- *Aluminum alloy jaws and steel spindle.*

**AL** Hecho en Aluminio  
Made in Aluminium

COD	MOD	A cm	B cm	C cm	Kg	
30002	A-20	0-7	4,5	3,5	1	1

Autoajutable a diferentes espesores.

Self adjustable to different thicknesses.

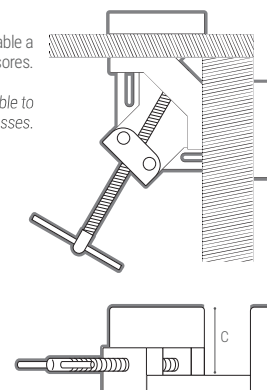

### MORDAZA DE ÁNGULO PARA METAL · WELDER'S ANGLE CLAMPS

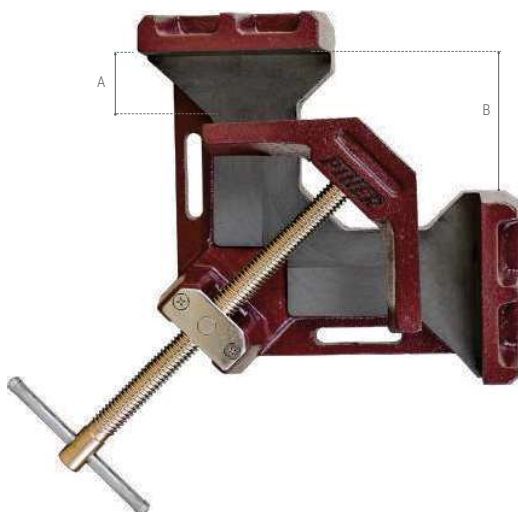

- Material: fundición nodular.
- Ajuste perfecto de las piezas de 90°.
- Tornillo con protección de baño de cobre antiadherente para proyecciones de soldadura.

- *Material: ductile cast iron.*
- *Copper plated non-stick screw for welding work.*
- *Screw with non-stick copper bath protection for welding projections.*

COD	MOD	A cm	B cm	C cm	Kg	
29998*	A-15	0-5,5	4	3,5	4,4	1
30001	A-10	0-8,5	6,5	3,5	5	
29999	A-00	0-12	10	6	9,2	

Autoajutable a diferentes espesores.

Self adjustable to different thicknesses.

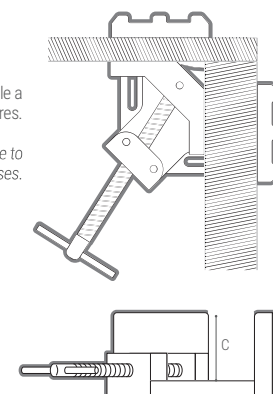

## TORNILLOS DE BANCO BENCH VICES

### TORNILLO DE BANCO CARPINTERO MÓVIL · PORTABLE CARPENTER'S BENCH VICE ·

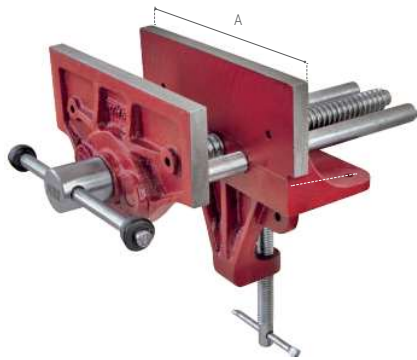

- Doble guía de acero (siempre paralelo).
- Bocas con ángulo de compensación.
- Bocas de fundición nodular.

- *Parallel double steel runners.*
- *Angled opening at rest.*
- *Ductile Cast iron Jaws.*

COD	A cm	B cm	C cm	Kg	📦
54004	15	5,5	12	2,75	1

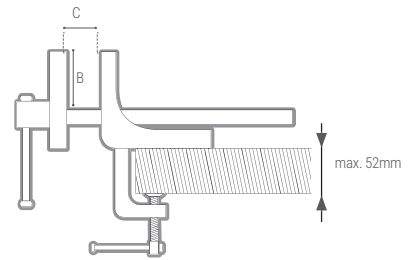

### TORNILLO DE BANCO CARPINTERO FIJO · CARPENTER'S BENCH VICE ·

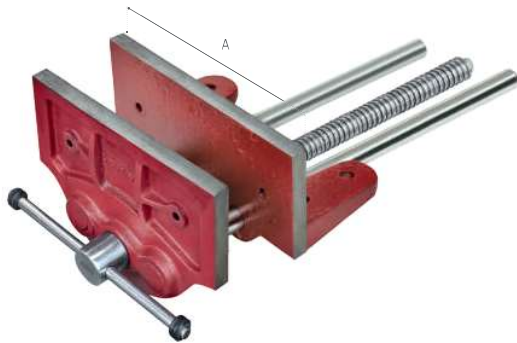

- Doble guía de acero (siempre paralelo).
- Bocas con ángulo de compensación.
- Bocas de fundición nodular.

- *Parallel double steel runners.*
- *Angled opening at rest.*
- *Ductile Cast iron Jaws.*

COD	A cm	B cm	C cm	Kg	📦
54006	15	5,5	12	2,3	1
54007	17,5	8	20	7,25	
54008	22,5	10	36	13,7	

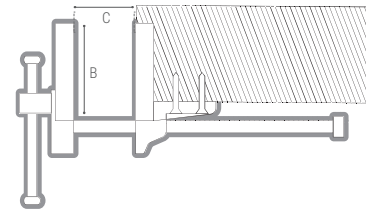

### HUSILLO FRONTAL PARA BANCO DE CARPINTERO · CARPENTER'S BENCH FOREHEAD SPINDLE ·



Fabricado en acero C-40  
Dureza de 45-51 HRC  
C-40 steel.  
Steel Hardness: 45-51 HRC

- Todas las piezas son de acero.
- Husillo, maneral y arandela cincada.

- *All parts are made of steel.*
- *Spindle, handle and galvanized washer.*

NEW

COD	A cm	Ø mm	Kg	📦
58018	37	18	1,4	1
58022	39	22	2	
58026	41	26	2,6	
58030	43	30	4	

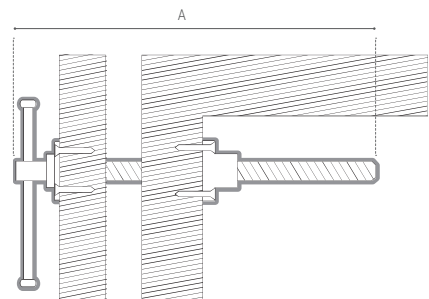

### TORNILLO MÓVIL GUÍA CUADRADA · PORTABLE BENCH VICE WITH SQUARE RUNNER

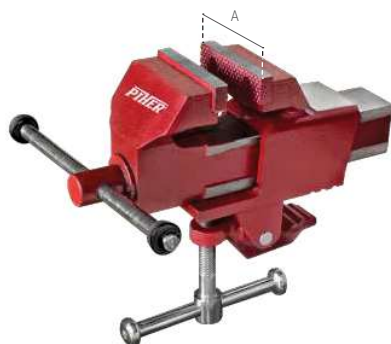

- Fundición nodular
- Mordazas intercambiables de acero templado.

- *Ductile cast iron.*
- *Interchangeable jaws.*

COD	A cm	B cm	C cm	Kg	📦
55007	6,5	4,5	10	3,69	1

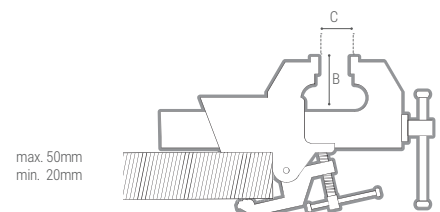

# TORNILLOS DE BANCO BENCH VICES

## TORNILLO DE BANCO GUÍA CUADRADA · ALL STEEL BENCH VICE WITH SQUARE RUNNER



Fabricado en acero forjado C-40  
Dureza de 45-51 HRC

C-40 Forged steel.  
Steel Hardness: 45-51 HRC

- Guía cuadrada ajustable.
- Mordazas intercambiables de acero templado.
- Base de yunque templado por inducción.
- Incluye de regalo mordazas de aluminio imantadas.

- Adjustable square runner.
- Interchangeable jaws.
- Induction hardened anvil base.
- Including magnetised aluminium pressure plates.



Con mordaza de amarre de tubo  
With jaw accessory for gripping tubes



Sin mordaza de amarre de tubo.  
Without jaw accessory for gripping tubes.



**BASE GIRATORIA DE FUNDICIÓN**  
CAST IRON SWIVEL BASE

COD	A cm	B cm	C cm	Max Ø cm	Kg	📦
55200	10,0	6,5	10,5	5	6,5	1
55225	12,5	8	13	6,5	11,94	
55250	15,0	10	16,5	8	19,25	

COD	A cm	B cm	C cm	Kg	📦
55100	10,0	6,5	10,5	6,35	1
55125	12,5	8	13	11,74	
55150	15,0	10	16,5	19	

COD	para-for  cm	Kg	📦
55101	10,0	0,97	1
55126	12,5	1,43	
55151	15,0	2	

### MORDAZAS DE ACERO TEMPLADO TEMPERED STEEL PRESSURE PLATES

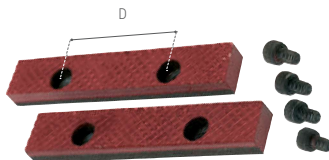

Juego de 2 unidades - Set of 2 units

COD	para-for MOD.	D cm	Kg	📦
55103	55100 - 10,0 cm	5	0,3	2
55128	55125 - 12,5 cm	7	0,4	
55153	55150 - 15,0 cm	8,5	0,7	
55008	55007 - 7 cm	4	0,3	

### PROTECTOR DE ALUMINIO MAGNÉTICO MAGNETISED ALUMINIUM PLATE



COD	para-for MOD.	Kg	📦
55001	55100 - 10,0 cm	0,1	2
55002	55125 - 12,5 cm	0,1	
55003	55150 - 15,0 cm	0,2	

### HUSILLO Y TUERCA GUÍA CUADRADA SQUARE RUNNER NUT AND SCREW



COD	para-for MOD.	Kg	📦
55102	55100 - 10,0 cm	0,7	1
55127	55125 - 12,5 cm	1,6	
55152	55150 - 15,0 cm	2,3	

**MORDAZA 702 · DRILL VICE 702**

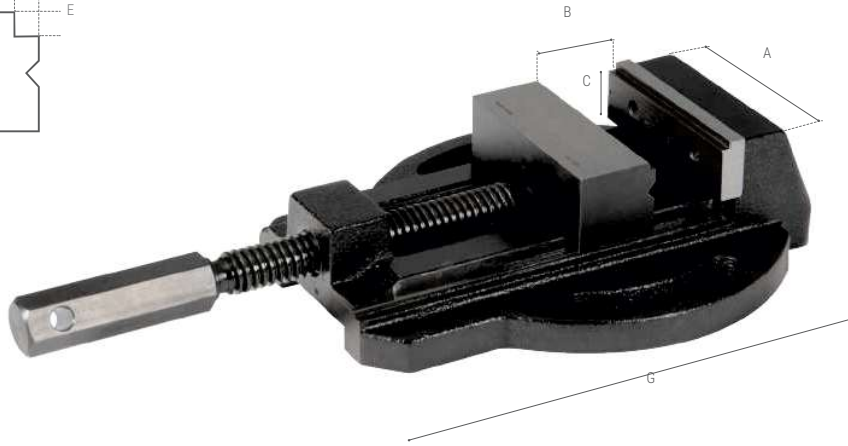
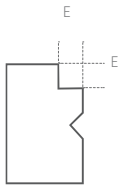

COD	A cm	B cm	C cm	G cm	E cm	Kg	
70210	8,5	9,5	2,55	18,8	0,30	4,0	1
70220	10,0	11,6	3,15	24,1	0,40	8,5	
70230	12,5	16,0	4,15	30,0	0,45	14,7	
70240	15,0	19,0	5,25	34,5	0,60	18,0	

- Fundición nodular.
- Bocas intercambiables de acero templada y rectificadas, con escalón y prisma a 90°.

- *Ductile cast iron.*
- *Smooth tempered steel changeable jaws with 90° step and prism.*

**MORDAZA 701 · DRILL VICE 701**

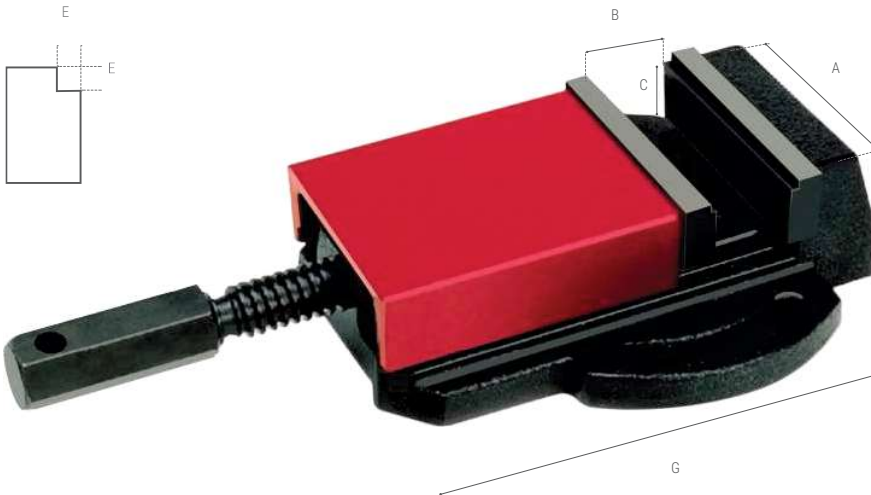
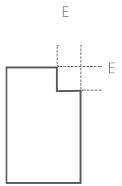

COD	A cm	B cm	C cm	G cm	E cm	Kg	
70110	6,5	7,6	2,55	16,3	0,30	2,7	1
70120	8,5	9,0	2,55	18,8	0,30	4,3	
70130	10,5	11,6	3,15	24,1	0,40	8,5	
70140	12,5	15,7	4,15	30,0	0,45	17,5	
70150	15,0	19,0	5,25	34,5	0,60	23	

- Fundición nodular.
- Bocas intercambiables de acero templada y rectificadas, con escalón.

- *Ductile cast iron*
- *Smooth tempered steel changeable jaws with step.*

**MORDAZA DE ACCIONAMIENTO RÁPIDO 703 · FAST ACTION DRILL VICE 703**



COD	A cm	B cm	C cm	D cm	E cm	F cm	S cm	Kg	
70320	27,5	9,0	2,0	8,5	42,0	10,3	0,8	10,5	1

- Fundición nodular.
- Bocas intercambiables de acero templada y rectificadas.
- Incluye dos juegos de bocas mecanizables de acero.
- *Nodular cast iron.*
- *Smooth tempered steel changeable jaws.*
- *Includes 2 sets of machineable steel jaws.*

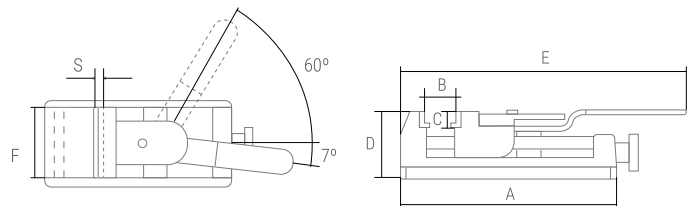

**PARA MESA DE ORIFICIOS PARA METAL Y MADERA  
FOR WORKING ON METAL & WOODEN HOLED TABLES**

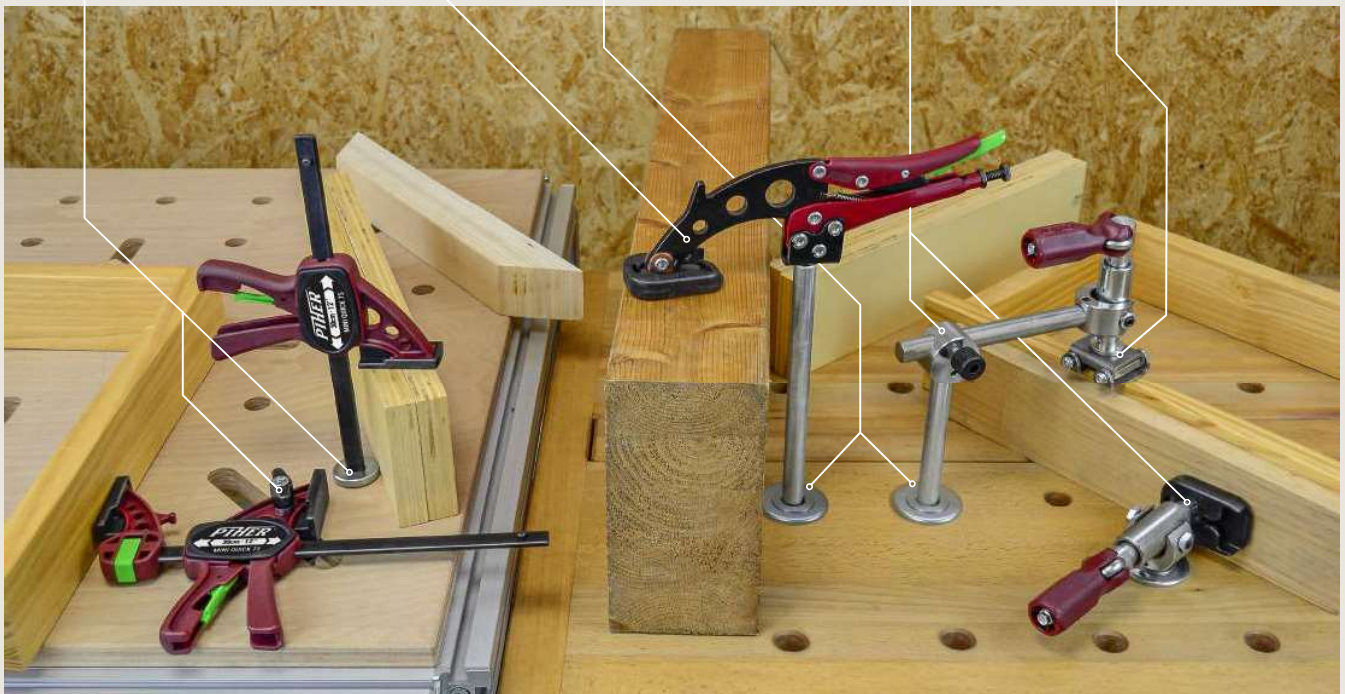
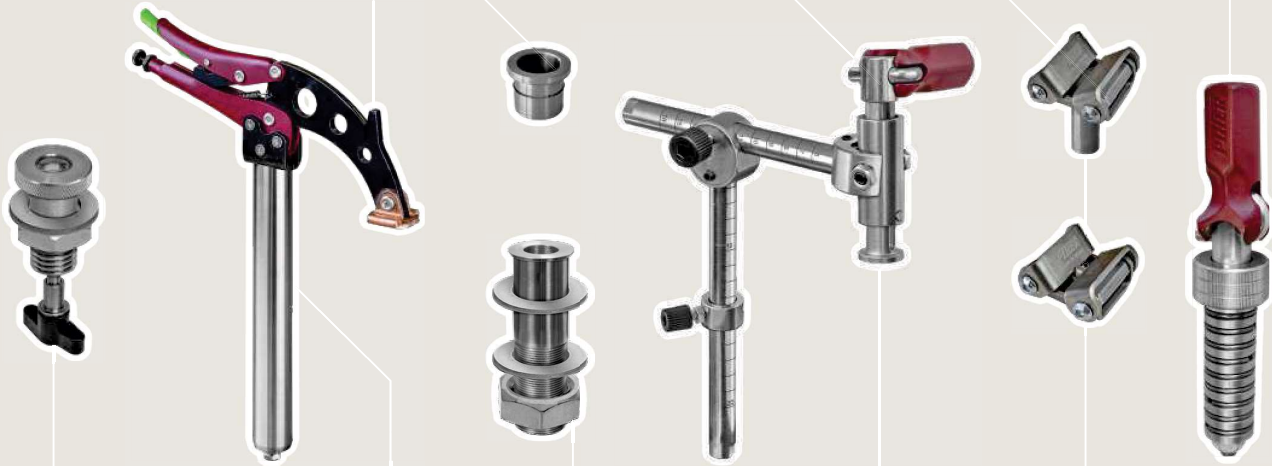
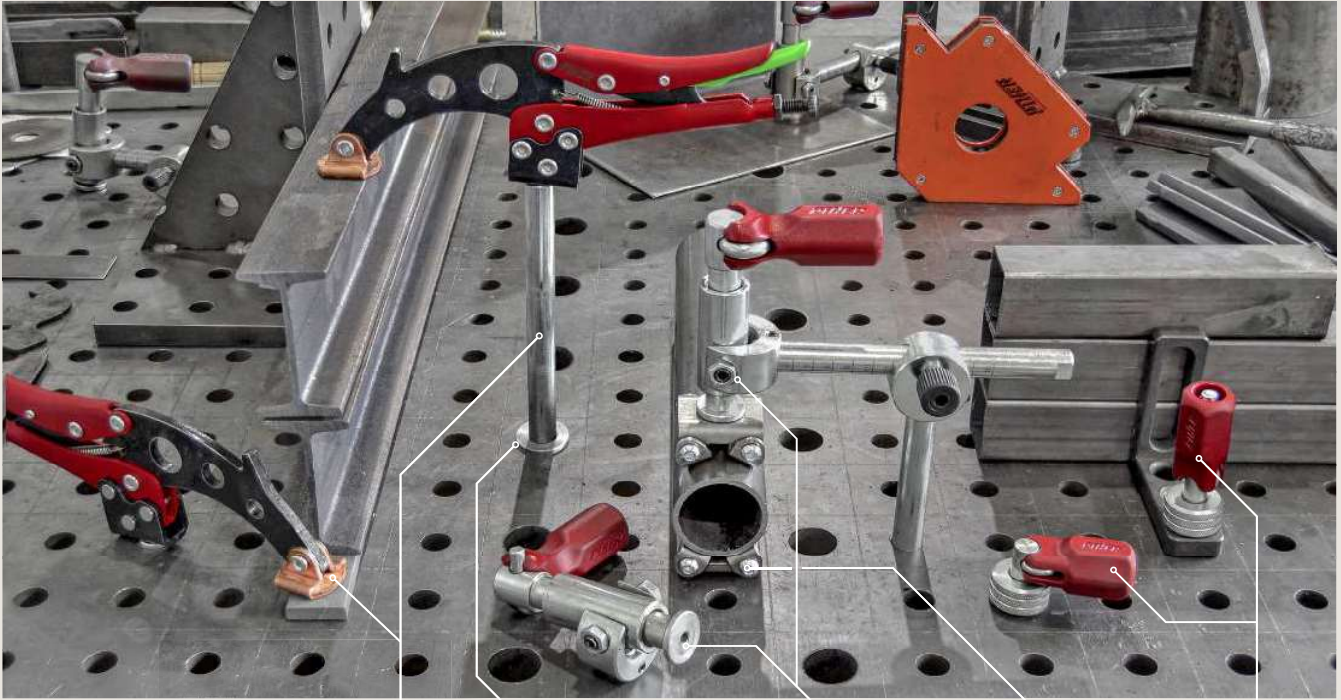

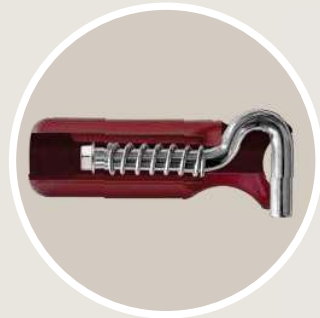

Mango ergonómico  
multiposición y recambiable.

*Ergonomically shaped handle,  
interchangeable  
and multi-positionable.*

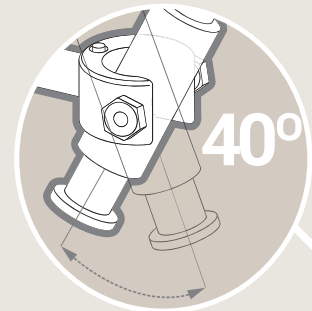

El émbolo bascula 40° para  
adaptarse a cualquier ángulo.

*The piston tilts 40°  
to adapt to any angle*

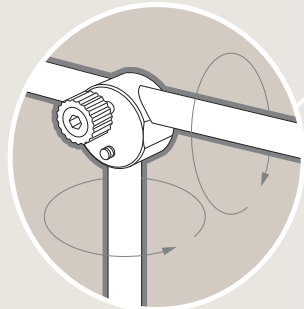

Para sujeción horizontal y  
vertical. Adaptable a 360°.

*For horizontal and vertical  
clamping. 360° adaptable*



La superficie de presión del  
émbolo tiene rosca M6 para el  
acoplamiento de accesorios.

*Piston pressure surface with  
M6 thread for assembling  
accessories.*

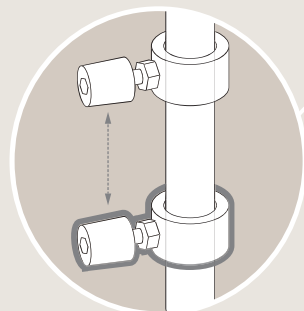

Tope móvil que permite ocultar  
completamente la barra por  
debajo de la mesa.

*Moveable stop that allows the bar  
to be completely hidden below  
the table.*

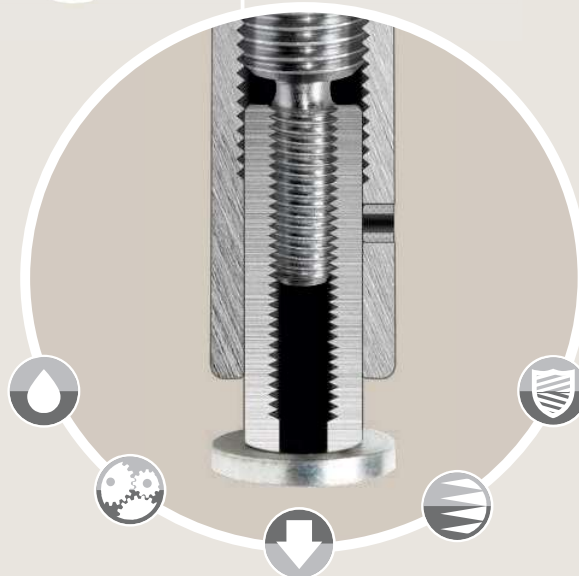

Sistema de émbolo PIHER:  
Doble rosca fina protegida de  
avance recto, sin rotación.

*PIHER Piston system inside:  
Protected double threaded piston  
with straight non rotating advance.*



COD. 19114  
Accesorio para Tubos  
Tube/pipe accessory



COD. 24014  
Protectores de Plástico  
Plastic Protection Caps

