



Motor Control Packages for the Single Phase Workshop

Supplied by



What is a Motor Control Package?

A Motor Control Package allows for the electronic variation of motor speed and typically comprises:

An Inverter / Variable Speed Drive (VSD):

The heart of the motor control package is the Variable Speed Drive. The VSD, also known as an Inverter, connects directly to the 3 phase motor and allows it to be powered from a single phase supply. The speed can be manually adjusted using a potentiometer. The VSD incorporates a soft-start/stop system and has a wealth of parameters that can be changed and customised to meet your machine requirements.



A 3-Phase Motor:

A 3 phase motor is essential for electronic speed control. The package can include a 3-phase, dual-voltage, single speed metric motor.



Motors are available in a range of power ratings & frame sizes, and we can even offer a B56 Imperial motor on some ratings.



The metric motors are available in B3 Foot mount, B5 Flange mount and B14 Face mount options, all of which are "TEFC" (Totally Enclosed and Fan Cooled).

The Imperial motors are available as a B56 Drip Proof Resilient Mount.

A Remote Control Station (RCS):

In order to provide a simple and robust method of controlling the motor, we supply a custom designed Remote Control that connects to the VSD. The RCS has large and easy to operate start and stop buttons, toggle switches for forward/reverse and run/jog as well as a potentiometer to control the speed.



So is a "Digital" Inverter also a Phase Converter?

Yes. "Digital" Inverters offer a 21st century approach to the dilemma of operating three phase motors from a single phase supply. These days, most people who are aware that a device exists to operate three phase equipment from single phase tend to know about inverters and assume that the concept has superseded the traditional "analogue" static or rotary phase converter. However, the two products will always co-exist as the technologies service different market requirements.



In contrast to the "Analogue" Static or Rotary Phase Converter:

- A "digital" **Inverter** fixes the voltage in the conversion (240v single phase to 0-240v 3-phase) and also varies the frequency (e.g. 0-400Hz) thereby offering motor control. The three phase supply at 240v is created by rectifying the ac supply to dc and inverting it back to ac (Hence the name **Inverter**).
- The involvement of DC means that **Inverter** supplies are defined as "Non-Linear". The input and output supply is subject to EMC regulation as the conversion process affects the a.c. single phase supply network. Current harmonics are present as a direct consequence. RF (Radio Frequency) mains filters may be required to ensure your contractual obligations to the electricity supply company are not compromised.
- As the output from an **Inverter** is 240-v 3-phase, an inverter cannot be accommodated without machine modification.
- The output from an **Inverter** can only be applied to one motor, or one load that starts and stops at the same time.
- **Inverter** manufacturers **do not offer product for single-phase supplies in excess of 3kW** to ensure compliance with European Power Quality Standards such as BSEN 61000-3-2:2006 and BS EN 61000-3-12:2005. For similar reasons **Inverter** manufacturers do not offer product with an output voltage that is different to the supply voltage (e.g.: 240v input, 415v output).

Can I retrofit an inverter to my existing single phase machine?

No, motor control is a three phase motor technology available for operation from both single phase and three phase electricity supplies. A single phase input inverter offers the facility to electronically vary the speed of a three phase motor from a single phase supply by varying the frequency of the supply to the motor.

It is not possible to vary the speed of a single-phase AC motor so if your machine is currently single-phase you will have to change the motor.

So are all 3-phase motors compatible with the output of an inverter?

Generally, yes. Most small single speed three-phase motors are wound for operation from **either** a 380/415v **or** a 220/240v 3-phase supply. A typical "dual-voltage" motor plate will indicate a voltage rating such as "**V 220-240 Δ / V 380-415 Y**" together with two current ratings. The lower current will refer to the higher voltage, the higher current to the lower voltage.

STAR CONFIGURATION – In the "Y" or "Star" configuration, the motor will run on a three phase supply from 380v to 415v phase to phase. The "Y" sometimes appears as a three-pointed star.

DELTA CONFIGURATION – In the "Δ" or "Delta" configuration, the motor will run on a three phase supply from 220v to 240v phase to phase. The "Δ" sometimes appears as a "D"

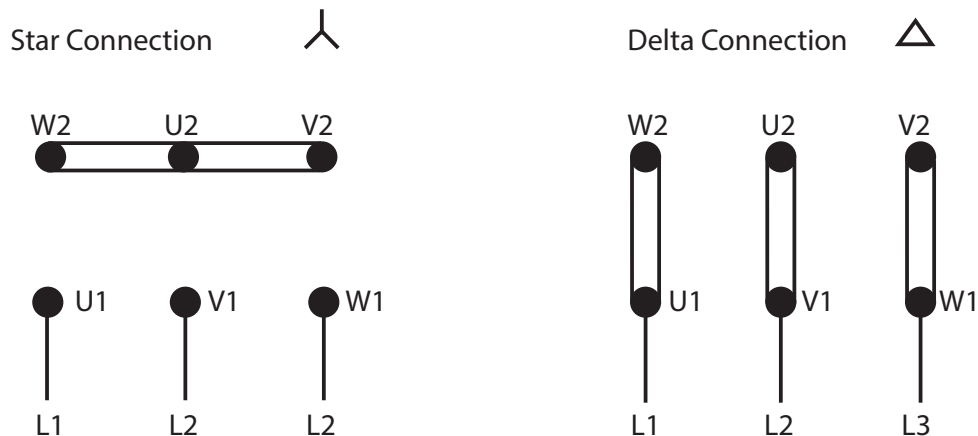

Fig. 1 above shows a typical motor terminal arrangement for the star configuration. Three terminals are linked together with a set of three brass/copper links. The other three terminals (commonly marked U1, V1 and W1) are then connected to the three phase 415v supply (L1, L2 and L3).

Fig. 2 above shows a typical motor terminal arrangement for the delta configuration. The three metal links are simply removed and rearranged. The other three terminals (U1, V1 and W1 as before) are then connected to a three phase 240v supply **or the output of an inverter/frequency converter**.

If the motor plate does not display a 240v three phase connection facility, it may still be possible to reconfigure the voltage rating from 415v to 240v three phase. Seek advice from a local motor repair or rewind company. A pole change three phase motor (displaying more than one synchronous speed e.g. 1400rpm/2800rpm) can only be connected for 380/415v so is usually incompatible with the output of a single phase inverter. This type of motor would have to be changed to a single speed, dual-voltage motor to facilitate the use of an inverter.

How do I connect a machine to the output of an inverter?

Once an existing three phase motor has been reconfigured from 415v operation (STAR) to 240v operation (DELTA), the equipment wiring loom (start/stop/forward/reverse/feed/coolant/limit switches etc) has to be disabled and is made redundant. The reconfigured motor is connected directly to the output of the inverter and the single phase supply is connected to the input of the inverter.

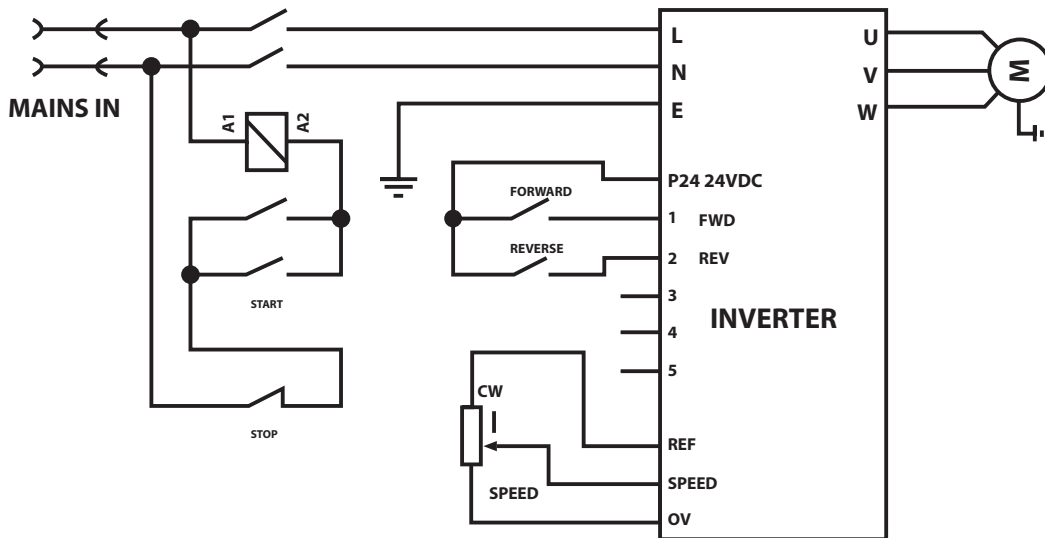

The SD1 inverter offers "local" control in the form of small buttons for start & stop and a potentiometer for speed adjustment.

For some people these buttons are an acceptable means of controlling the motor; however the majority find the buttons too small and impractical.

We highly recommend a remote control station/pendant (see image) for a minimum additional outlay, which offers the basic control functions in an acceptable form. The pendant connects directly to the inverter control terminals and comes with a 2 metre length of cable so it can be mounted in an appropriate area of the machine. The inverter itself can then be put out of harm's way.



The motor must be connected directly to the inverter output so controls should not "make and break" the supply to the motor under any circumstances. Be wary of ancillary motors such as coolants and table feeds. These are likely to have to be disconnected completely and fed from an alternative source, as are lighting circuits and control transformers.

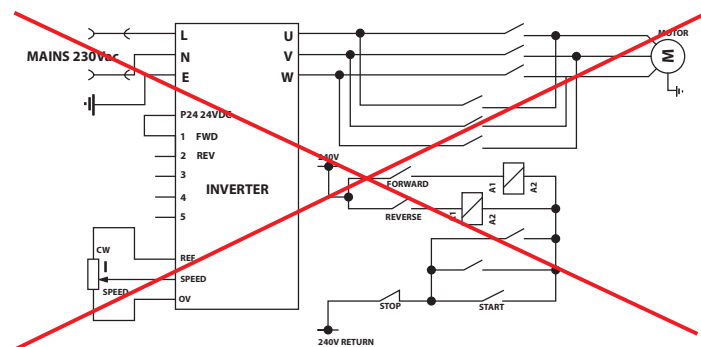

It is possible to rewire a machine wiring loom to the inverter control terminal rail so that existing switchgear/levers/limit switches etc can be used. Seek advice from a competent electrician as there is often a lot of work involved.

What performance can I expect from the motor once it has been connected to the SD1 inverter?

The speed of an induction motor is directly related to its supply frequency. The frequency from your single phase supply is fixed at 50Hz, so if the output from the inverter is set at 50Hz the motor will operate at its synchronous speed (e.g. 750-1000-1500-3000rpm). Any mechanical ratios will operate at plated mechanical speeds. Your inverter is simply acting as a phase converter under these circumstances.

The relationship between frequency and speed is linear, so if the frequency of the supply to the motor is reduced by 50% (to 25Hz) the motor speed is reduced Pro-rata. So, theoretically, as the SD1 inverter offers a range of 0-200Hz, your machine can now operate between zero speed and four times motor speed.

Understandably this leads to an assumption that belt/pulley changing is a thing of the past.

Unfortunately, there is a relationship between the frequency at which a motor operates and the power/torque it can deliver.

We recommend that SD1 Inverters are used in conjunction with, rather than as a direct replacement for, an existing mechanical variation of speed. It is better to achieve a 50rpm shaft speed from a 100rpm geared speed at 25Hz than a 250rpm geared speed at 10Hz.

Users of SD1 inverters, are recommended to pre-set the frequency window to ensure that the level of torque available is acceptable.

At particularly low frequencies, it may be necessary to consider the implications of secondary motor cooling since the fan built into the motor could lose its ability to cool the motor effectively. At higher frequencies than 50Hz, it is in the user's interest to check that the integrity of the driven motor/ machine will not be compromised at the higher speeds involved.

Added benefits of using an inverter are a soft-start in the form of a controlled acceleration over a time determined by the machine-user. Similarly, there is a controlled deceleration option, dc braking and "reverse-on-the-fly", a particularly useful feature when tapping or screw-cutting. Once you have programmed the software parameters to meet your requirements, the parameters do not need to be changed again.





Technical Datasheet

SD1 Series

General Purpose AC Variable Speed Inverter Drives

1 Phase 200/240V 50/60Hz 0.4~2.2kW (0.5~3HP)

3 Phase 200/240V 50/60Hz 0.4~7.5kW (0.5~10HP)

3 Phase 380/440V 50/60Hz 0.75~110kW (1~150HP)

- IP20
- Torque Vector Control
- STO (safe torque off)
- Up to 150% Starting Torque
- Front Mounted RJ45 Socket (<2.2kW)
- Din Rail Mountable (<2.2kW)
- Fixed Keypad with Potentiometer (<2.2kW)
- Detachable Keypad (≥4kW)
- HDI Input (pulse)
- 2 Analogue Inputs
- 1/2 Analogue Outputs
- 2 Output Relays
- Transistor Output
- 4/5 Digital Inputs
- PNP/NPN Selectable
- In Built Modbus RTU / RS485
- PID Control as standard
- Internal DC Reactor (≥18.5kW)
- DC Injection Braking
- Internal Brake Chopper (≤37kW)
- Motor Auto-tune (static & dynamic)
- Internal C3 Filter (≥4kW), C3 Filter Option (<2.2kW)
- C1 & C2 Filter Options (entire range)
- Safety Circuit (SIL2/SIL3 - model dependant)
- CE, RoHS & Reach Compliant
- TUV Approved
- UL / cUL Approval on selected models
- 2 Year Warranty



Ordering Information

SD1 - 2.5A - 43																																					
Series	SD1 Inverter Drive																																				
Output Power kW (HP)	<table border="1"> <tr> <td>0.75kW (1HP)</td> <td>2.5A</td> <td>11kW (15HP)</td> <td>25A</td> <td>45kW (60HP)</td> <td>92A</td> </tr> <tr> <td>1.5kW (2HP)</td> <td>4.2A</td> <td>15kW (20HP)</td> <td>32A</td> <td>55kW (75HP)</td> <td>115A</td> </tr> <tr> <td>2.2kW (3HP)</td> <td>5.5A</td> <td>18.5kW (25HP)</td> <td>38A</td> <td>75kW (100HP)</td> <td>150A</td> </tr> <tr> <td>4kW (5.5HP)</td> <td>9.5A</td> <td>22kW (30HP)</td> <td>45A</td> <td>90kW (125HP)</td> <td>180A</td> </tr> <tr> <td>5.5kW (7.5HP)</td> <td>14A</td> <td>30kW (40HP)</td> <td>60A</td> <td>110kW (150HP)</td> <td>215A</td> </tr> <tr> <td>7.5kW (10HP)</td> <td>18.5A</td> <td>37kW (50HP)</td> <td>75A</td> <td></td> <td></td> </tr> </table>	0.75kW (1HP)	2.5A	11kW (15HP)	25A	45kW (60HP)	92A	1.5kW (2HP)	4.2A	15kW (20HP)	32A	55kW (75HP)	115A	2.2kW (3HP)	5.5A	18.5kW (25HP)	38A	75kW (100HP)	150A	4kW (5.5HP)	9.5A	22kW (30HP)	45A	90kW (125HP)	180A	5.5kW (7.5HP)	14A	30kW (40HP)	60A	110kW (150HP)	215A	7.5kW (10HP)	18.5A	37kW (50HP)	75A		
0.75kW (1HP)	2.5A	11kW (15HP)	25A	45kW (60HP)	92A																																
1.5kW (2HP)	4.2A	15kW (20HP)	32A	55kW (75HP)	115A																																
2.2kW (3HP)	5.5A	18.5kW (25HP)	38A	75kW (100HP)	150A																																
4kW (5.5HP)	9.5A	22kW (30HP)	45A	90kW (125HP)	180A																																
5.5kW (7.5HP)	14A	30kW (40HP)	60A	110kW (150HP)	215A																																
7.5kW (10HP)	18.5A	37kW (50HP)	75A																																		
Input	380-400V Three Phase																																				

SD1 - 2.5A - 23															
Output Power kW (HP)	<table border="1"> <tr> <td>0.4kW (0.5HP)</td> <td>2.5A</td> </tr> <tr> <td>0.75kW (1HP)</td> <td>4.2A</td> </tr> <tr> <td>1.5kW (2HP)</td> <td>7.5A</td> </tr> <tr> <td>2.2kW (3HP)</td> <td>10A</td> </tr> <tr> <td>4kW (5.5HP)</td> <td>16A</td> </tr> <tr> <td>5.5kW (7.5HP)</td> <td>20A</td> </tr> <tr> <td>7.5kW (10HP)</td> <td>30A</td> </tr> </table>	0.4kW (0.5HP)	2.5A	0.75kW (1HP)	4.2A	1.5kW (2HP)	7.5A	2.2kW (3HP)	10A	4kW (5.5HP)	16A	5.5kW (7.5HP)	20A	7.5kW (10HP)	30A
0.4kW (0.5HP)	2.5A														
0.75kW (1HP)	4.2A														
1.5kW (2HP)	7.5A														
2.2kW (3HP)	10A														
4kW (5.5HP)	16A														
5.5kW (7.5HP)	20A														
7.5kW (10HP)	30A														
Input	200-240V Three Phase														

SD1 - 2.5A - 21									
Output Power kW (HP)	<table border="1"> <tr> <td>0.4kW (0.5HP)</td> <td>2.5A</td> </tr> <tr> <td>0.75kW (1HP)</td> <td>4.2A</td> </tr> <tr> <td>1.5kW (2HP)</td> <td>7.5A</td> </tr> <tr> <td>2.2kW (3HP)</td> <td>10A</td> </tr> </table>	0.4kW (0.5HP)	2.5A	0.75kW (1HP)	4.2A	1.5kW (2HP)	7.5A	2.2kW (3HP)	10A
0.4kW (0.5HP)	2.5A								
0.75kW (1HP)	4.2A								
1.5kW (2HP)	7.5A								
2.2kW (3HP)	10A								
Input	200-240V Single Phase								

REF: SD1 Datasheet 0619
 Errors and omissions excepted.
 Subject to change without notice.
 © 2019 IMO Precision Controls Ltd

SD1 Series

General Purpose AC Variable Speed Inverter Drives



Power & Control Connections

Technical Datasheet

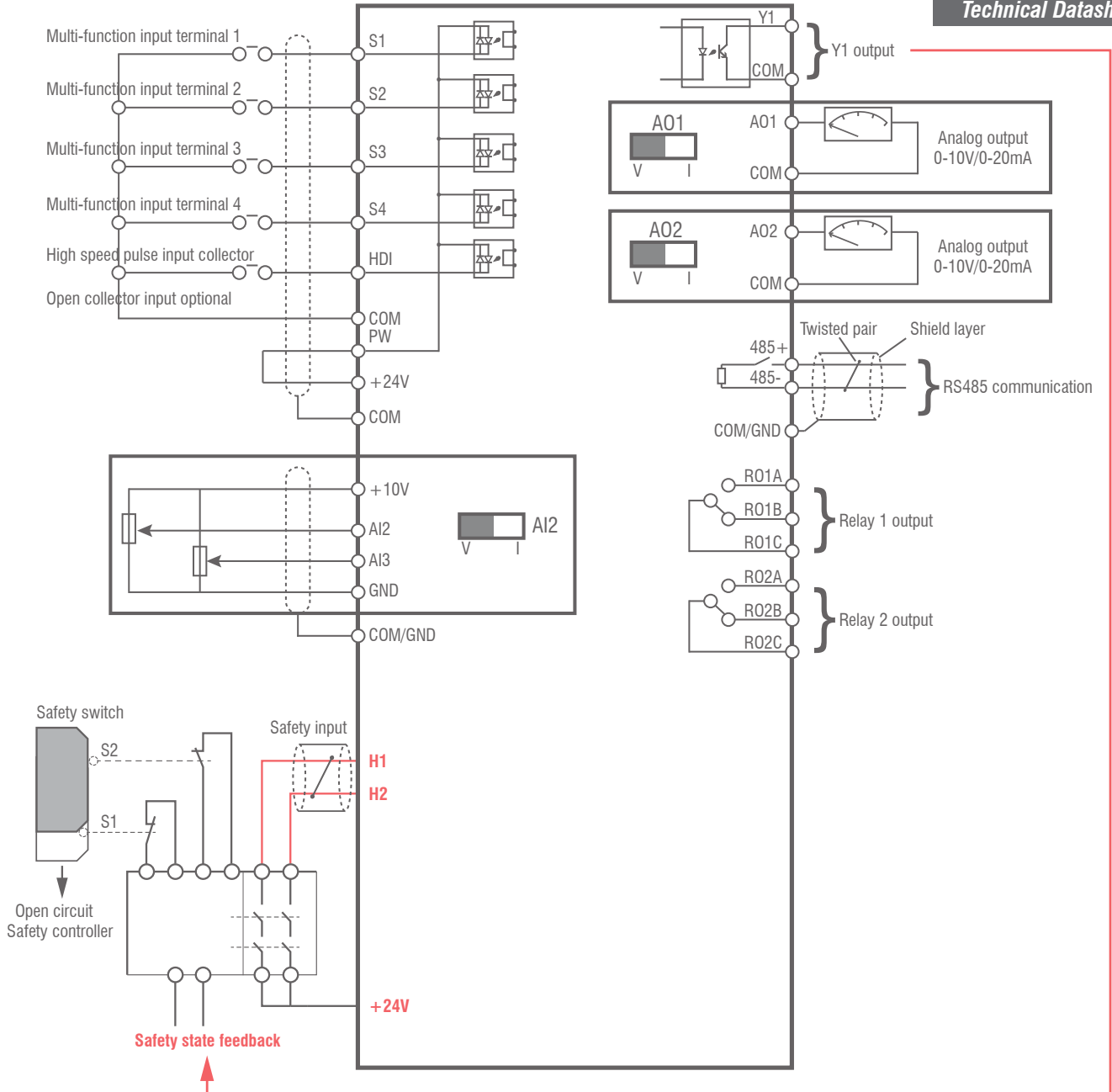

REF: SD1 Datasheet 0619
 Errors and omissions excepted.
 Subject to change without notice.
 © 2019 IMO Precision Controls Ltd

THE RCS:

REMOTE CONTROL STATION for IMO SD1 INVERTER



This control pendant allows you to access the software of the inverter remotely, bypassing the buttons on the inverter itself.

DIMENSIONS

150mm (high) x 80mm (wide) x 50mm (deep). Enclosure has four fixing holes for mounting purposes.

START BUTTON (GREEN)

The inverter software will allow the user to pre-programme the motor acceleration time. Motor will "soft-start" in a controlled fashion when this button is pushed.

STOP BUTTON (RED)

(Incorporating no-volt release safety feature)
Inverter software will allow the motor to coast, decelerate or brake to a stop when this button is pushed. The inverter software will allow the user to pre-programme the motor deceleration time. Motor will stop in a controlled fashion when this button is

pushed. The motor will not re-start automatically if power to the inverter is lost and then restored. This is a very important safety feature not offered by all manufacturers of control pendants.

FORWARD/REVERSE SWITCH & RUN/JOG SWITCH

In "Run" Mode, the motor can be stopped and restarted in the opposite direction using the reversing switch. The motor can also be reversed "on-the-fly". This feature decelerates the motor to a standstill and then accelerates the motor back up to speed in the opposite direction without "stopping" the motor – very useful for screw-cutting and milling applications. In "Jog" mode, the motor will inch/jog at the requested frequency rather than run continuously.

POTENTIOMETER

Rated at 10KΩ, this potentiometer is the means by which the user controls the speed of the motor. Maximum and minimum frequency settings/speeds are pre-programmed via the inverter software.

SCREENED CABLE

The control pendant is fitted with a 2 metre length of 7-core screened cable for connection directly to the inverter control terminal rail.



DIMENSIONAL DATA SHEET

EFF 2 *TECA SERIES*

B3 FOOT MOUNT

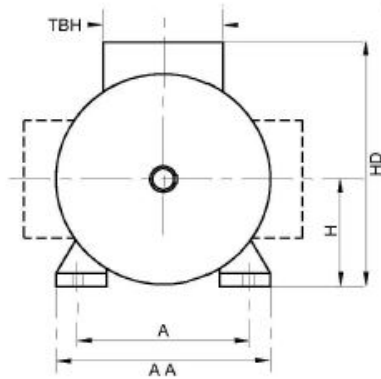
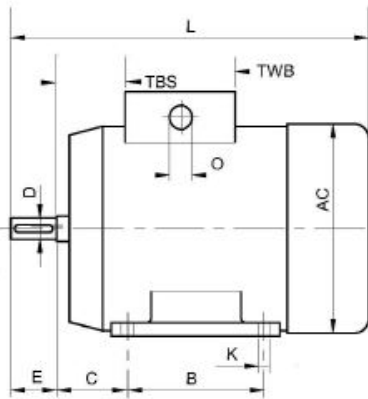

Dimensions in MM
Shaft Dimensions

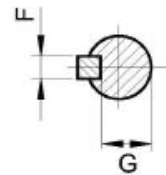

FRAME SIZE	MAIN DIMENSIONS			B3 FOOT DIMENSIONS							SHAFT			TERMINAL BOX			
	L	AC	Ø	AA	B	A	H	HD	K	C	D	E	G	F	TBS	TBW	TBW
56	195	120	1*M16	110	71	90	56	156	5.8	36	9	20	7.2	3	14	88	88
63	215	130	1*M16	120	80	100	63	173	7	40	11	23	8.5	4	14	94	94
71	255	145	1*M20	132	90	112	71	188	7	45	14	30	11	5	20	94	94
80	290	165	1*M20	160	100	125	80	217	10	50	19	40	15.5	6	27	105	105
90S	310	185	1*M20	175	100	140	90	235	10	56	24	50	20	8	30	105	105
90	L1 335	185	1*M20	175	125	140	90	235	10	56	24	50	20	8	30	105	105
	L2 365																
100	386	205	1*M20	196	140	160	100	252	12	63	28	60	24	8	26	105	105
112	395	230	2*M25	220	140	190	112	292	12	70	28	60	24	8	32	112	112
132 S	436	270	2*M25	252	140	216	132	325	12	89	38	80	33	10	38	112	112
132	M 475	270	2*M25	252	178	216	132	325	12	89	38	80	33	10	38	112	112
	L 500																
160	M 620	320	2*M32	290	210	254	160	390	15	108	42	110	37	12	64	143	143
	L 254																

DIMENSIONAL DATA SHEET

EFF 2 **TECA SERIES**

B5 FLANGE MOUNT

Dimensions in MM

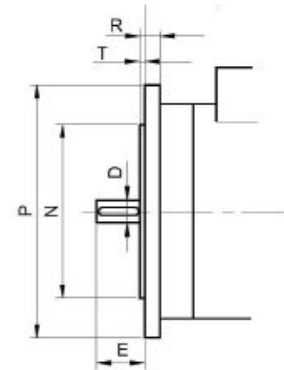
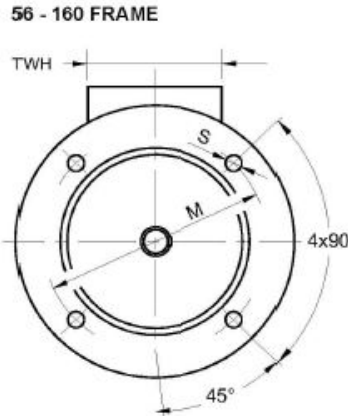
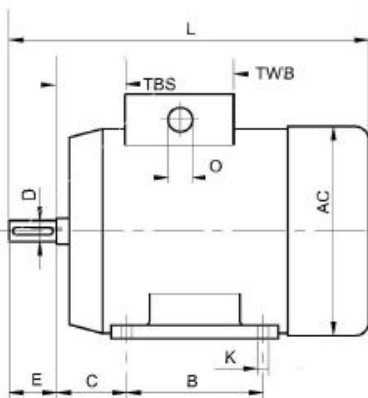

FRAME SIZE	MAIN DIMENSIONS			B5 FLANGEDIMENSIONS							SHAFT				TERMINAL BOX		
	L	AC	Ø	TYPE	P	N	M	R	S	T	D	E	G	F	TBS	TBW	TBW
56	195	120	1*M16	FA	120	80	98	0	7	3	9	20	7.2	3	14	88	88
63	215	130	1*M16	FA	140	95	115	0	10	3	11	23	8.5	4	14	94	94
71	255	145	1*M20	FA	160	110	130	0	10	3.5	14	30	11	5	20	94	94
80	290	165	1*M20	FA	200	130	135	0	12	3.5	19	40	15.5	6	27	105	105
90S	310	185	1*M20	FA	200	130	135	0	12	3.5	24	50	20	8	30	105	105
90	L1 335	185	1*M20	FA	200	130	135	0	12	3.5	24	50	20	8	30	105	105
	L2 365																
100	386	205	1*M20	FA	250	180	215	0	15	4	28	60	24	8	26	105	105
112	395	230	2*M25	FA	250	180	215	0	15	4	28	60	24	8	32	112	112
132 S	436	270	2*M25	FA	300	230	255	0	15	4	38	80	33	10	38	112	112
132	M 475	270	2*M25	FA	300	230	235	0	15	4	38	80	33	10	38	112	112
	L 500																
160	M 620	320	2*M32	FA	350	250	300	0	19	5	42	110	37	12	64	143	143
	L																

Shaft Dimensions

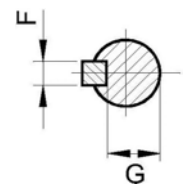

DIMENSIONAL DATA SHEET

EFF 2 IMPERIAL B56 RESILIENT MOUNT

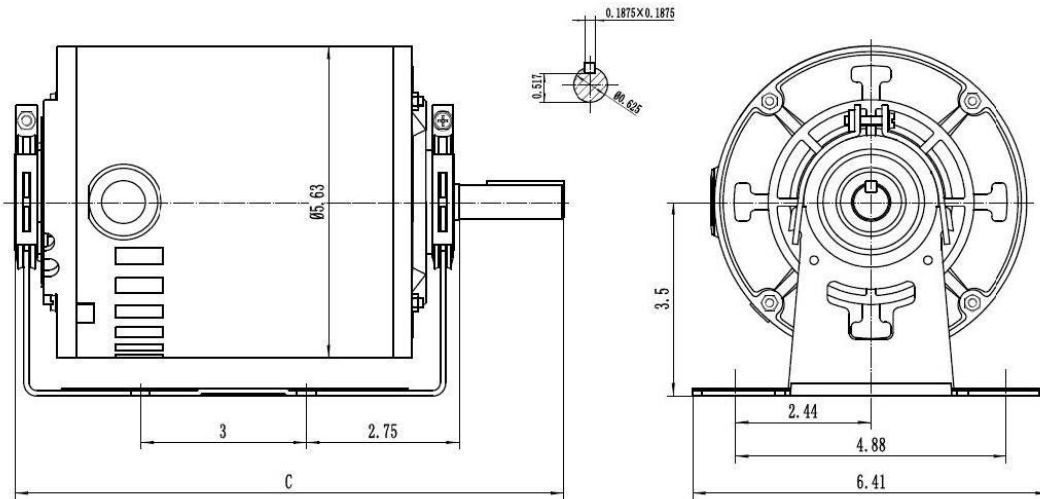

56TT140-SP-560	11.4
56TT140-SP-375	10.8
	C



30 Redfern Road, Tyseley, Birmingham. B11 2BH

Telephone: 0121-708-4522 | Freephone: 0800-035-2027
 transwave@powercapacitors.co.uk | www.transwave.co.uk
 linkedin.com/company/power-capacitors-limited

© Power Capacitors Ltd 2021

