

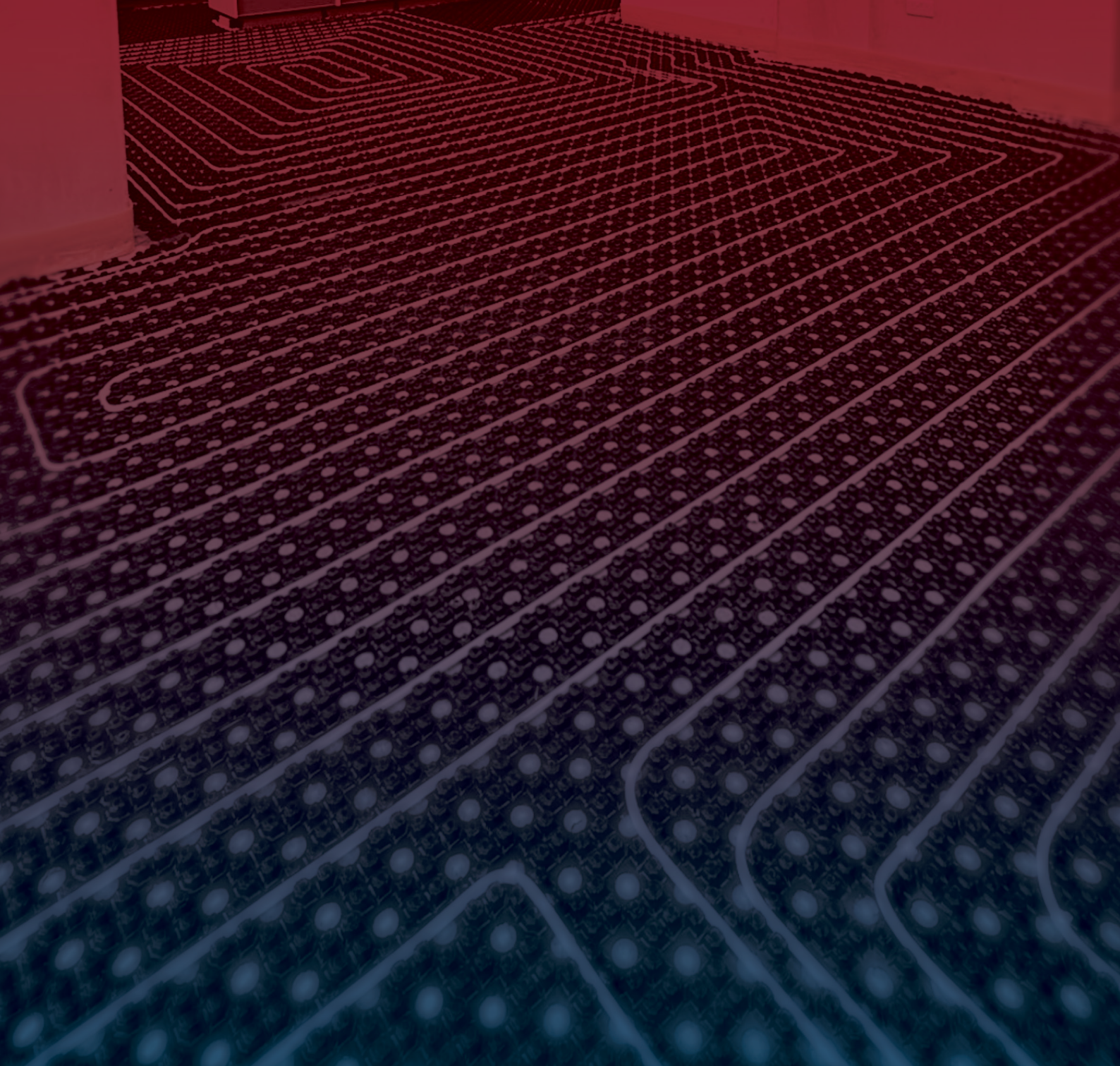

**tio**  
**HeatCool**  
Heating & Cooling System



# Contents

<b>Heating and Cooling</b>	<b>03</b>
<b>Overview</b>	<b>04</b>
<b>Reversible Thermostat</b>	<b>06</b>
<b>Heating and Cooling Switch</b>	<b>07</b>
<b>Dew Point Sensor</b>	<b>08</b>
<b>Wiring Centre</b>	<b>09</b>

**Heating and Cooling**

The Tio Reversible Floor Heating and Cooling System offers a simple and cost-effective solution for floor heating systems where a heat source is able to deliver cool water in summer periods for circulation through a normal Underfloor heating set up.



Product Code	Product Description
TIOSTA0013	230v white floor heating and cooling thermostat
TIOSTA0014	230v black floor heating and cooling thermostat
TIOSWI0001	Tio Smart switch
TIOSEN0002	Tio Dew point sensor
TIOWIRO002	5 Zone wiring control Centre with valve and timer port (230V)
TIOWIRO004	8 Zone wiring control Centre with valve and timer port (230V)

During winter heating periods the system operates in the same way as a normal UFH system, with a basic distribution manifold (non-mixing). A Tio Reversible Room Thermostat allows a dedicated manifold valve to open when the room temperature is below the required temperature set point, the warm water circulates through the floor heating the room.

In summer periods a 230v signal is sent to the manifold wiring centre to switch the unit into cooling mode (the Tio Smart Switch can be used to generate this signal and can also be used to switch a volt free signal from the ASHP/GSHP). When this signal is received, the system and thermostat operation is reversed allowing manifold valve actuators to open when the room temperature is above the desired set point thus allowing cool water through the manifold loops in order to cool the room.

The manifold and wiring centre are fitted with a Dew Point sensor which prevents the system running if condensation build up is present on the manifold body. This is used as a safety feature only to protect building fabric in times of high humidity and not as a primary control, cool water to the manifold should be supplied above dew point.

The system is only suitable for basic distribution manifolds (non-mixing) as there is no capacity for localised blending of water temperature, water must be supplied to the manifold at suitable temperature to circulate through the floor, typically 35°C-45°C for heating and 15°C-20°C (above dew point) for cooling.

Please note that any sized Tio wiring centre can be used in a heating or heating and cooling application.

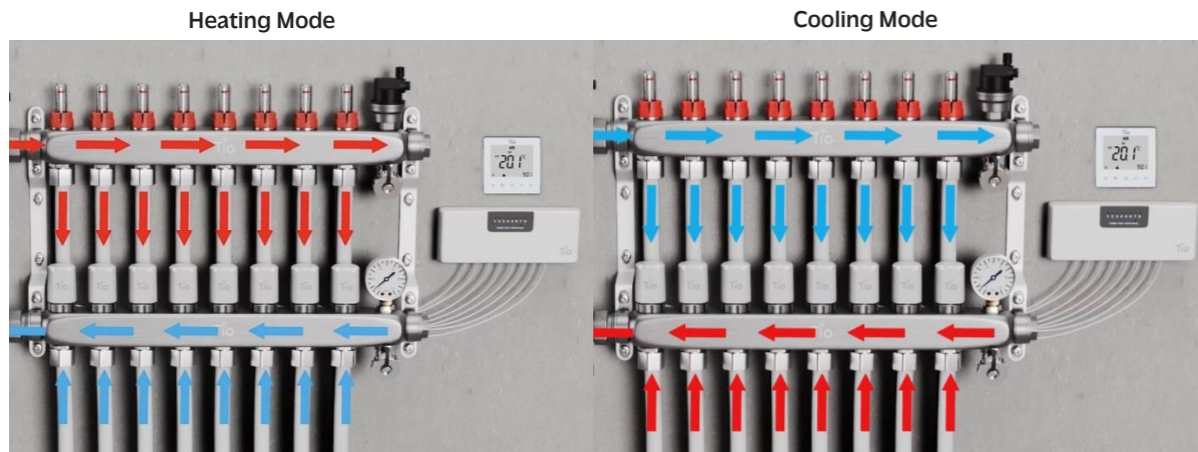

System allows warm water to circulate through the floor.

System allows cold water to circulate through the floor.

**Overview**

There are 5 key components to a heating and cooling system. The manifold, wiring centre, thermostat, heating and cooling switch and a dew point sensor.

Operating your thermostat as you would regularly for heating, setting the temperature to your desired value using up and down, whilst ensuring the switch is in heating mode. Your thermostat will display a sun when it is in heating mode. You will see the wiring centre activate the designated zone.

To switch into cooling mode, toggle the heating and cooling switch into cooling mode. A snowflake icon will appear on your thermostat. You will now have to lower the temperature setting on your thermostat in order to activate the function. You will notice the desired zone on the wiring centre light up.

A Dew Point sensor is fitted to detect condensation on the manifold body. If detected, the pump and demand is disabled.

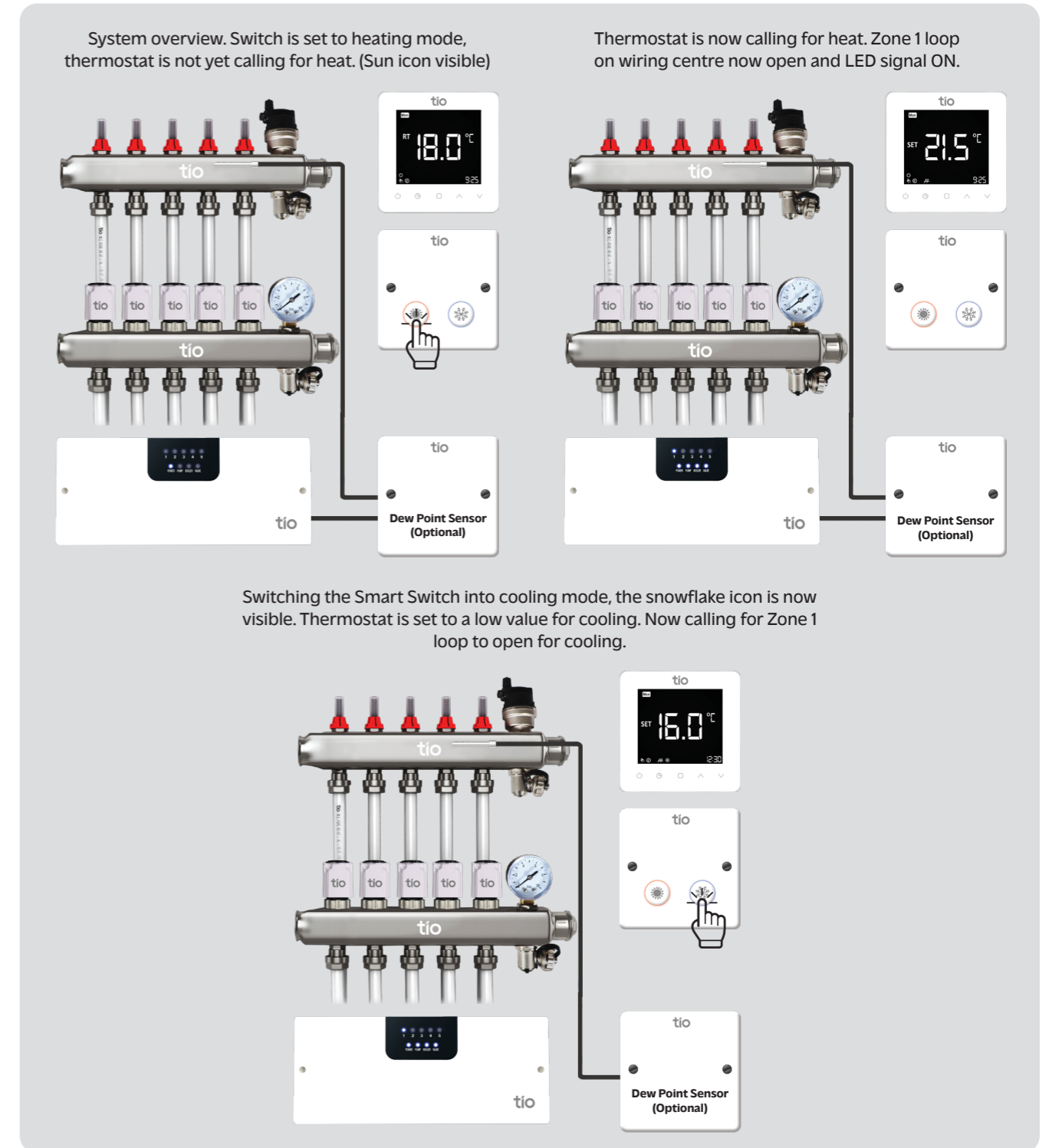

System Flow Diagram

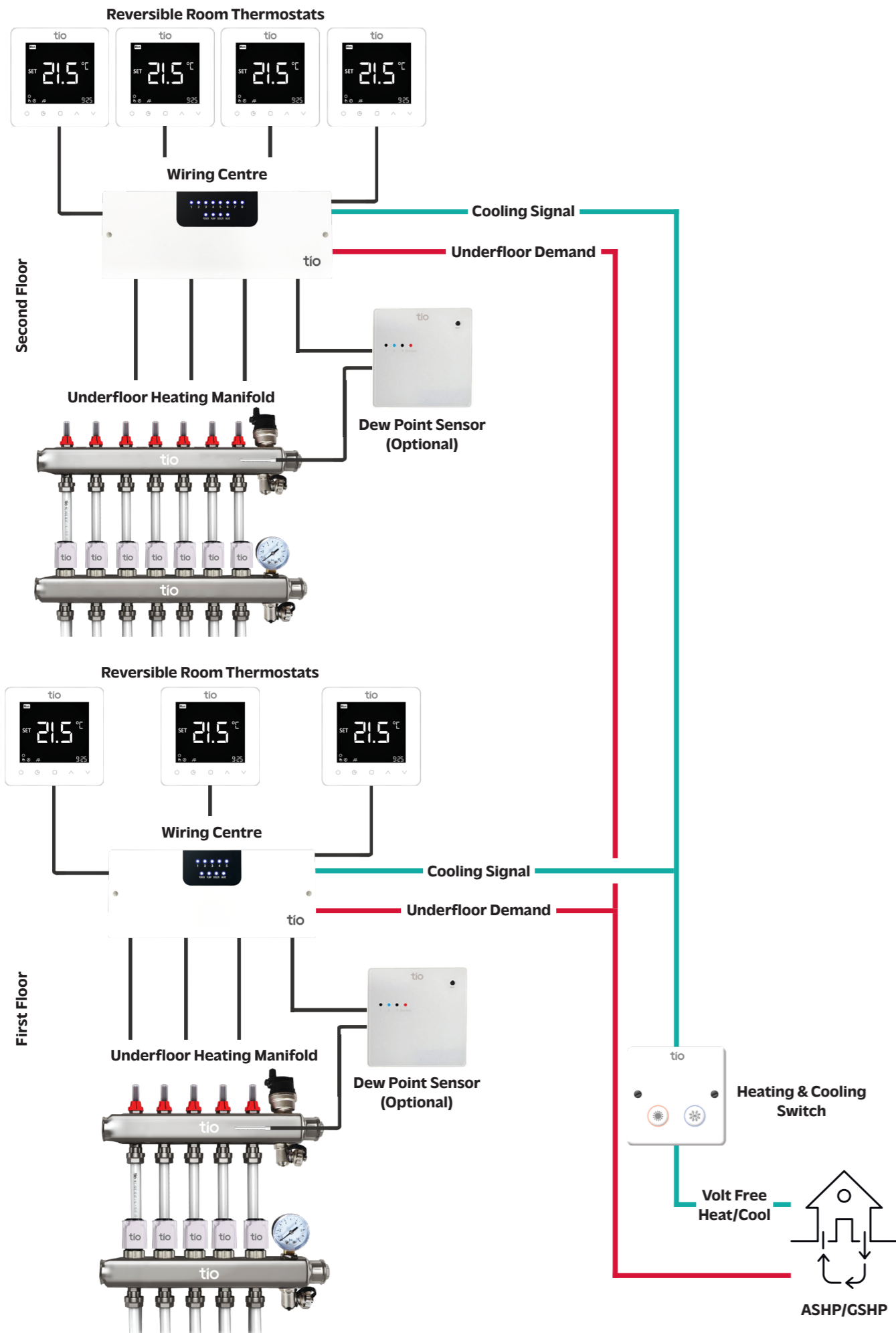

Reversible Heating and Cooling Thermostat with Integral Dew Point Sensing

A Tio Reversible Room Thermostat allows a dedicated manifold valve to open when the room temperature is below the required temperature set point, the warm water circulates through the floor heating the room.



Product Code	Product Description
TIOSTA0013	230v white reversible thermostat with integrated dew sensor
TIOSTA0014	230v black reversible thermostat with integrated dew sensor

Thermostat Details

Power Consumption: < 1.5W Timing Error: <1 %  
 Power Supply: 95 - 240VAC, 50 ~60Hz  
 Current Load: 5A (water heating, water/gas boiler)  
 Shell material: PC+ABS (flame retardant)  
 Dimension: 86x86x13.3mm  
 (Non-condensing) Ambient Temperature: 0-45°C, 5-95% RH  
 Storage Temperature: -5-55°C  
 5 + 1 + 1, six period per day programming  
 Pre-set temperatures maintained within +/- 0.5°C  
 Internal and external sensors for both air and/or floor temperatures

Factory Settings:

Please note that you must first, pick your desired mode (heating or cooling) and then programme accordingly to your personal preference.

Heating Mode:

Time Display	Monday - Friday		Saturday		Sunday	
	Time	Set Temperature	Time	Set Temperature	Time	Set Temperature
Period 1	06:00	22°C	06:00	22°C	06:00	22°C
Period 2	08:00	16°C	08:00	16°C	08:00	16°C
Period 3	12:00	22°C	12:00	22°C	12:00	22°C
Period 4	14:00	16°C	14:00	16°C	14:00	16°C
Period 5	18:00	22°C	18:00	22°C	18:00	22°C
Period 6	22:00	16°C	22:00	16°C	22:00	16°C

Cooling Mode:

Time Display	Monday - Friday		Saturday		Sunday	
	Time	Set Temperature	Time	Set Temperature	Time	Set Temperature
Period 1	06:00	24°C	06:00	24°C	06:00	24°C
Period 2	08:00	28°C	08:00	28°C	08:00	28°C
Period 3	12:00	24°C	12:00	24°C	12:00	24°C
Period 4	14:00	28°C	14:00	28°C	14:00	28°C
Period 5	18:00	24°C	18:00	24°C	18:00	24°C
Period 6	22:00	28°C	22:00	28°C	22:00	28°C

Fig. 1 Thermostat Wiring

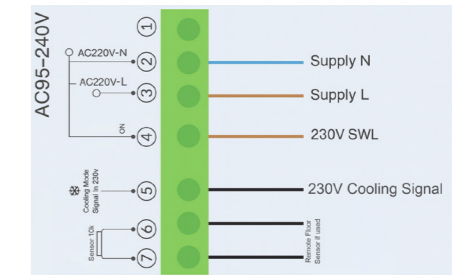

Configuration Menu:

No.	Function	Press ^ v to set	Default
1	Temp. Calibration	-9°C to 9°C	0°C
2	Dead zone	0.5°C to 5°C	0.5°C
3	Lock	0: All buttons will operate 1: All buttons will lock except power	0
4	Sensor selection	IN: Internal sensor OU: External sensor ALL: Both sensors operating	ALL
5	Minimum temperature setting	5°C to 15°C	5°C
6	Maximum temperature setting	15°C to 45°C	35°C
7	Display mode	0: Room Temperature 1: Setting Temperature	0
8	Standby backlight	0 - 100	10
9	High temperature protection setting	25°C to 70°C	45°C
10	Anti-freeze temperature range	2°C to 10°C	5°C
11	Anti-freeze protection	0: OFF 1: ON	0
12	Eco Mode	0: OFF 1: ON	0
13	Eco heating temperature range	5°C to 30°C	16°C
14	Eco cooling temperature range	5°C to 30°C	28°C
15	Backlight	0 - 100	80
16	RH% Humidity Calibration	-10°C to 10°C	0
17	Dew point cut off (external sensor)	0°C to 9°C	2°C
18	Dew point cut off (internal sensor)	0°C to 9°C	4°C
19	Disable cooling function	0: Cooling Function ON 1: Cooling Function OFF	0

Each thermostat is fitted with an integral RH (relative humidity) sensor which monitors RH% valves and calculates the resultant dew point. In cooling mode the thermostat floor probe is used as a cut off to prevent the floor becoming cold enough for moisture in the air to condensate.

Factory setting for floor probe cut off is 2°C above dew point, however this is adjustable between 0 and 9°C within the units configuration menu. If the floor temperature reaches this set point the demand function is disabled and the unit flashes RH%, thermostat demand will automatically resume once atmospheric conditions permit. Hold down the timer button for 7 seconds to show RH%, press again for Dew Point temperature, again for floor probe temperature and finally on/off to return to main display. It is recommended the floor probe is used for system efficiency however, the thermostat can operate without a probe and has a factory setting dew point cut off of 4°C measured at the thermostat location. If the floor probe is not connected the thermostat will flash an error message 'Floor Err'. Change the probe settings within the configuration to 'IN' if no probe is being used.

The cooling function can also be disabled completely for areas where cooling is not required in summer months such as bath and shower rooms, when disabled it is possible to use a remote probe for heating function only.

### Heating and Cooling Switch

The Tio Heating and Cooling switch is used to switch between summer cooling and winter heating periods when used in conjunction with the Heating and Cooling thermostat.

The switch can also be used to switch heat sources such as ASHPs between heating and cooling via an additional volt free relay.



Product Code	Product Description
TIOSWI0001	Tio Smart switch

### Operation

Operating your thermostat as you would regularly for heating, setting the temperature to your desired value using up and down, whilst ensuring the switch is in heating mode. Your thermostat will display a sun when it is in heating mode. You will see the wiring centre activate the designated zone.

To switch into cooling mode, toggle the heating and cooling switch into cooling mode. A snowflake icon will appear on your thermostat. You will now have to lower the temperature setting on your thermostat in order to activate the function. You will notice the desired zone on the wiring centre light up.

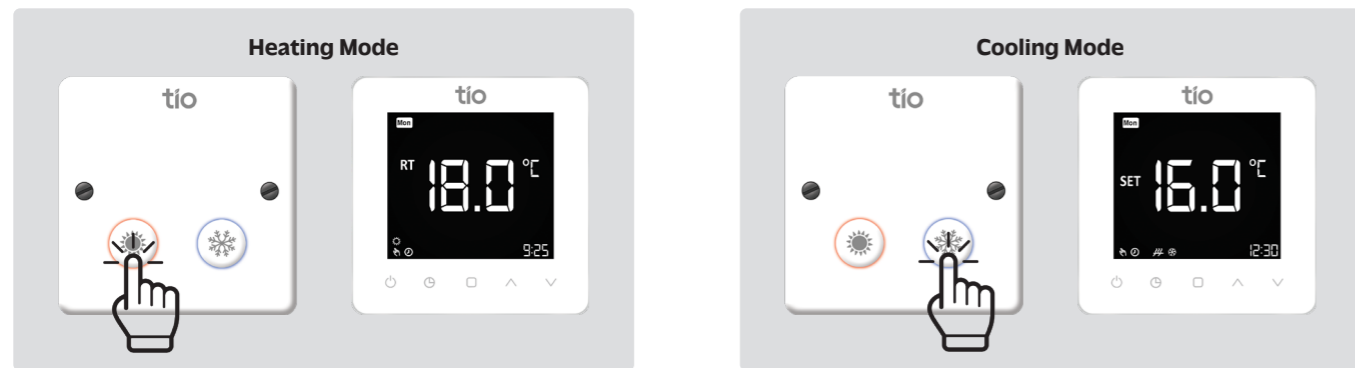
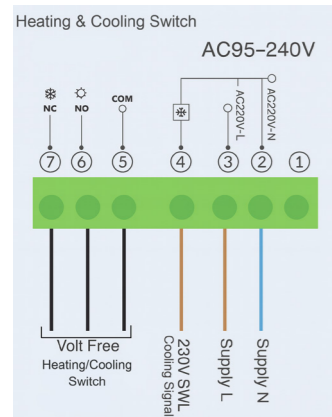

Fig. 2 Switch Wiring



### Dew Point Sensor

The Tio Dew Point Sensor is designed for use in conjunction with the heating and cooling thermostat and Heating and cooling switch, the sensor probe is strapped to the underfloor manifold body and will disable the wiring centre's demand and pump signals and also close the system zone valve as the manifold body approaches dew point. The sensor can also be used in any application where high-level humidity detection is required.



This is an optional feature as our dedicated thermostat has an integral dew point sensor.

Product Code	Product Description
TIOSEN0002	Tio Dew point sensor

The sensor comes with a 2.5m fly lead probe and 8A volt free switching relay.

The unit has 3 pre-programmed settings offering versatile operation and compatibility with both plastic and metal pipework and manifolds.

Set Points can be adjusted by holding down the 'set' button for 3 seconds :

- 1 – **Low Set** – Equivalent to 92-95%RH
- 2 – **Medium Set** – Equivalent to 95-98%RH
- 3 – **High Set** – Equivalent to 100%RH

The Sensor light will illuminate if the set point is exceeded.

Fig. 3 Wiring Centre & Zone Valve Connection

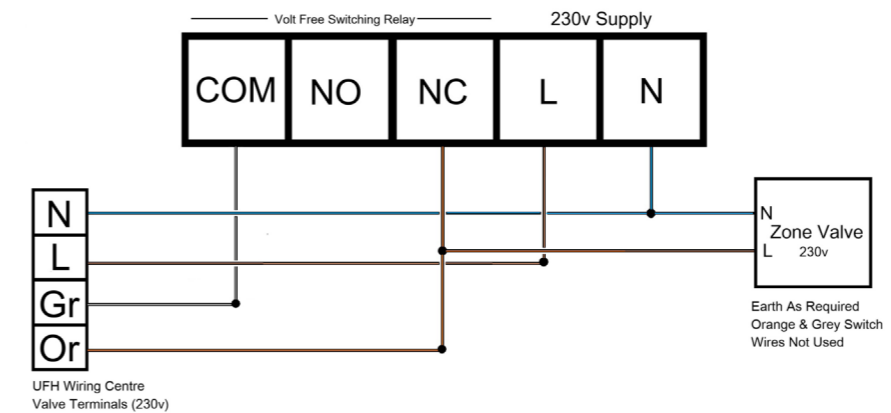

### Wiring Centre

Please note that any sized Tio wiring centre can be used in a heating or heating and cooling application. A 5 zone wiring centre has been used for the purpose of this demonstration.

Product Code	Product Description
TIOWIR002	5 Zone wiring control Centre with valve and timer port (230V)
TIOWIR004	8 Zone wiring control Centre with valve and timer port (230V)



### Wiring Schematic

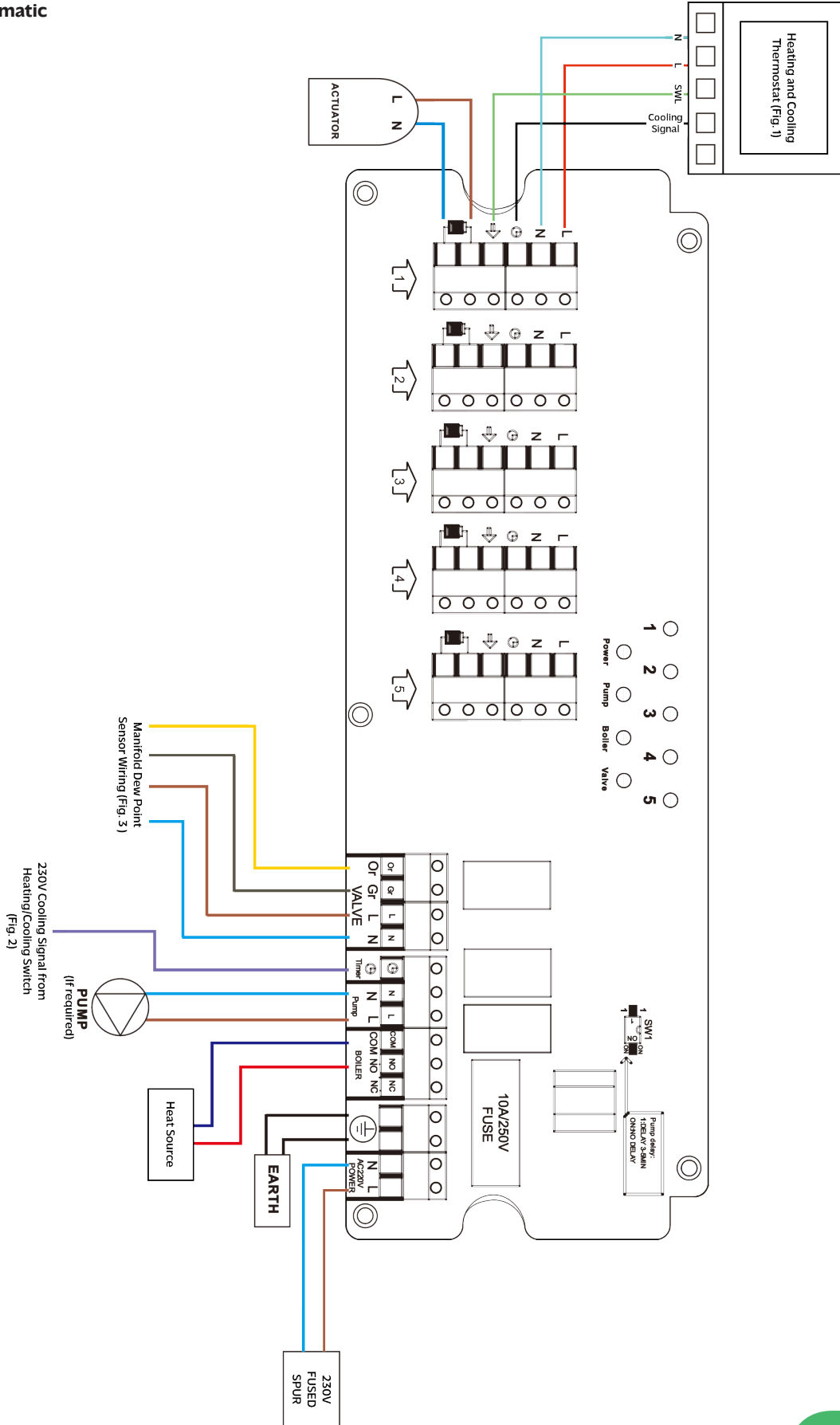

Partnered with  
**PIPEX**  
THINK FLEXIBLE

Products for the  
**Built Environment**



[www.tioclimatesolutions.co.uk](http://www.tioclimatesolutions.co.uk)