

maskin mekano

**SH 1202**

MOBILE FINAL SCREEN



# Screening made safe and easy

A screening plant is a workplace. During development work much emphasis has been placed on creating a safe work environment. Maskin Mekano's engineers have developed several new and reliable safety guards.

To facilitate the change of screen meshes, Maskin Mekano also has a number of unique solutions. Proper catwalks are located on the side and behind the screen box and are reached via hydraulic folding stepladders equipped with handrails and a self-closing barrier. The feeding conveyor folds straight up for complete access to the upper deck. In front of the screen, the chute can be rolled away hydraulically.

In addition, Maskin Mekano's development team have worked hard to minimise the need for operator intervention on the machine. An example of this is that all bearing components on the conveyors have centralised lubrication.

SH 1202 has large rubber wheels for transport at the site. The handling hook is located at the "right" end of the machine, and fits easily under the loading conveyor from crusher, feeder or other sorting plant. It's fast to set up and move. The high hydraulic jacking legs make it easy keep the area around the machine tidy in the quarry. They are also designed for easy loading onto a trailer, just back up between the support legs, hoist them up and fold them in. This results in a transport width of less than 3 m (9.8'). It is also possible to transport the machine with a hook truck that can carry 18 tons.

The electrical distribution box is ready for interlinking with forward or connecting machine. SH 1202 can be equipped with an online electrical cabinet that enables our service technician to help users troubleshoot or calibrate the machines remotely.

## DECKS



2

## SCREEN AREA



1.4 X 4.8 (4.6 x 15.7')

## WEIGHT



18.000

## TRANSPORT



Trailer

## CONSUMPTION



20 kW

## SET UP TIME



10 minutes





- Easy transports thanks to the hook-lift frame
- Easy to load on a trailer thanks to the high jacking legs
- Easy to place under a conveyor thanks to the hook in the rear
- Easy to tow thanks to the rubber wheels
- Easy to set up, will only take a couple of minutes
- Easy to change meshes thanks to clever design
- Easy maintenance thanks to accessible construction and few lubrication points
- Easy stockpiling thanks to long side conveyors



Because of the handy format and wide application possibilities the SH 1202 will undoubtedly increase the versatility of your fleet of machines. Use it as a standalone screen, together with the crusher, a screening plant or in a stationary production line to split a fraction, instead of stopping the entire application for change of screening meshes.

## Screen STE 2-67

The STE 2-67 is a four bearing screen with a strong 12 mm circular stroke and 11° elevation, operating at 800 rpm. It measures 1.4 x 4.8 metres (4.6 x 15.7') on two decks. The STE-screen has an unsurpassed screening ability and responds very well to current clean screening requirements as well as high capacity demands.

The on-board wrap around sturdy cat walks ease inspection and provide maximum accessibility to the screen box. The upper deck screening media is side tensioned, and the

feeding conveyor can be risen for a total overview of the upper deck. Also the chutes in front of the screen box are slideable to facilitate the change of meshes even more. The lower deck is end tensioned. There are covered inspection panels in the sides of the screen box for inspection. The lower deck can be installed with ball deck.

## The Vibroblock concept

The Maskin Mekano Vibro Block concept means the screen box is mounted on a vibration damped frame which prevents the vibrations from the screen from transmitting to the chassis. This saves the entire plant from damages caused by vibration, whilst the screening motion remains efficient. The Vibro Block design allows the STE screen to operate with the capacity of a four bearing screen as smooth as a two bearing screen, and keeps the power in the screen-box where it belongs.



### FEATURE

**Powerful stroke**

### EFFECT

**Effective stratification**

### RESULT

**High capacity**

**Shallow inclination**

**Effective separation**

**High quality**



## Feeding

The feeding conveyor is wide in order to present an optimal spread across the screen. The feed-in-height in the highest operation level is 3.2 m (10.5'), but it is easily adjusted with the jacking legs.

## Stockpiling

The SH 1202 is fitted with three hydraulically foldable on board stockpiling conveyors. Folding is performed without any twisting of belts and without any manual handling, which reduces set-up time. All drum motors are cambered and gummed.

## Construction

The SH 1202 is mounted on a sturdy chassis. The four jacking legs are raised and lowered hydraulically, so the area around the plant is easy to keep clean. They also facilitate loading on a trailer. SH 1202 is fitted with big rubber wheels for towing on site, and there is a hook for handling placed

in the rear, which makes it simple to place the screen under feeding conveyors or a crusher conveyor. For maximum operator security there are fully integrated stairs, hydraulically folded, with handrails and there are solid on board catwalks.

## Electric drive for low costs

All Maskin Mekano plants are electrically driven which means their diesel consumption is up to 60% lower than hydraulically driven plants. Noise impact is reduced to a minimum. The electrical cabinet is fitted with sockets for interlocking with crusher or extra conveyors, providing possibility to stop these units via the emergency stops on the SH 1202.

## Profitable investment

Because of the rugged construction a Maskin Mekano plant keeps the value like no other plant. The outstanding capacity and low operating costs make the investment profitable. The high second-hand value makes it safe. All wear and spare parts are stored in Jönköping and all customers are given professional advise and support from our service engineers.



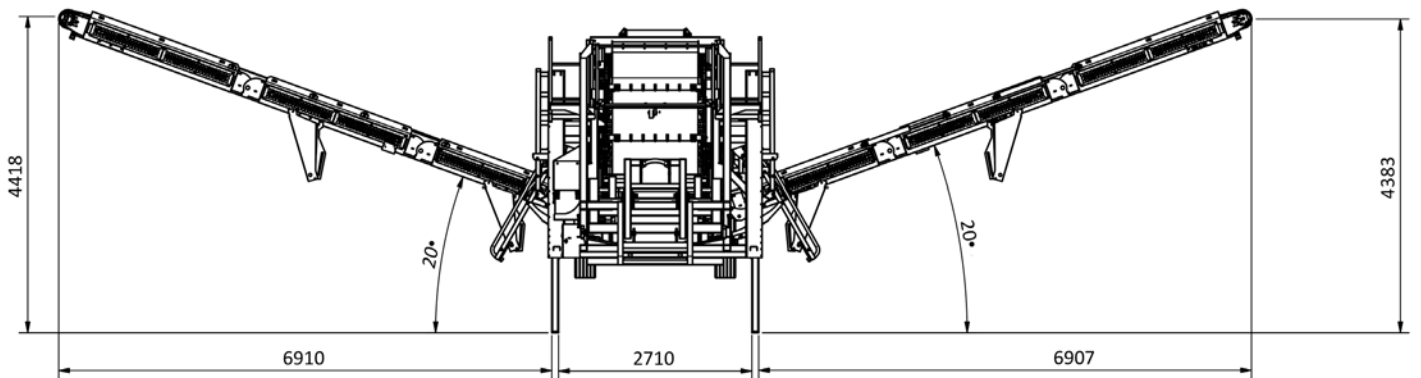
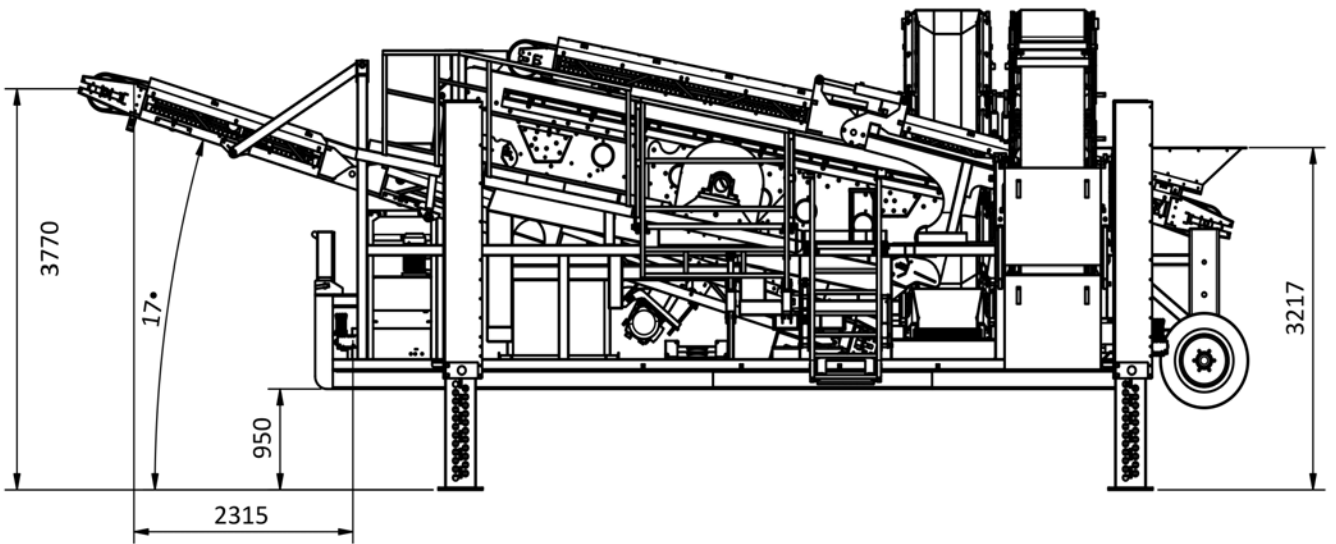
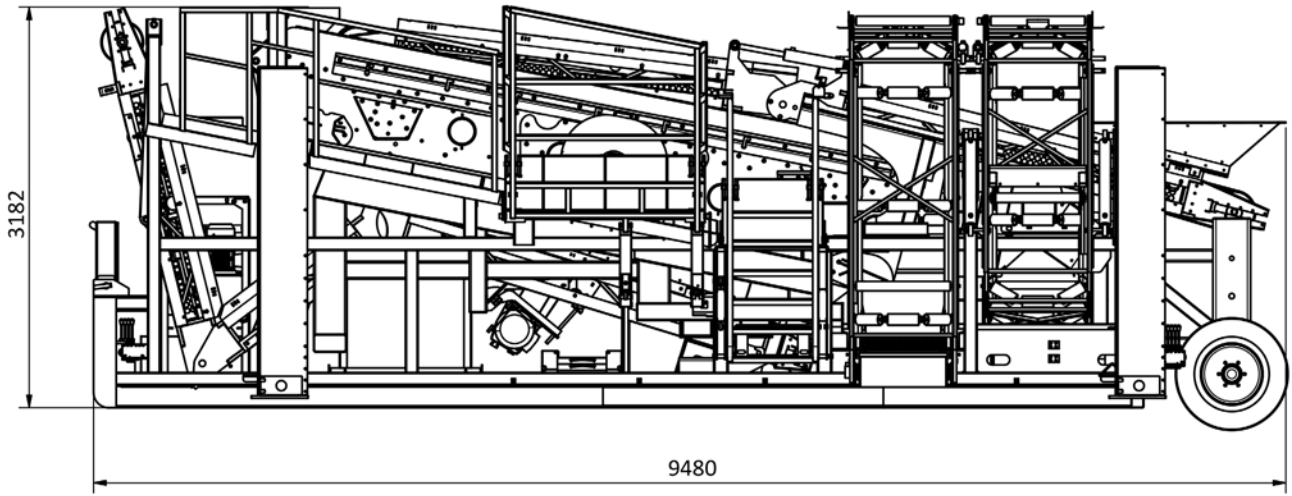

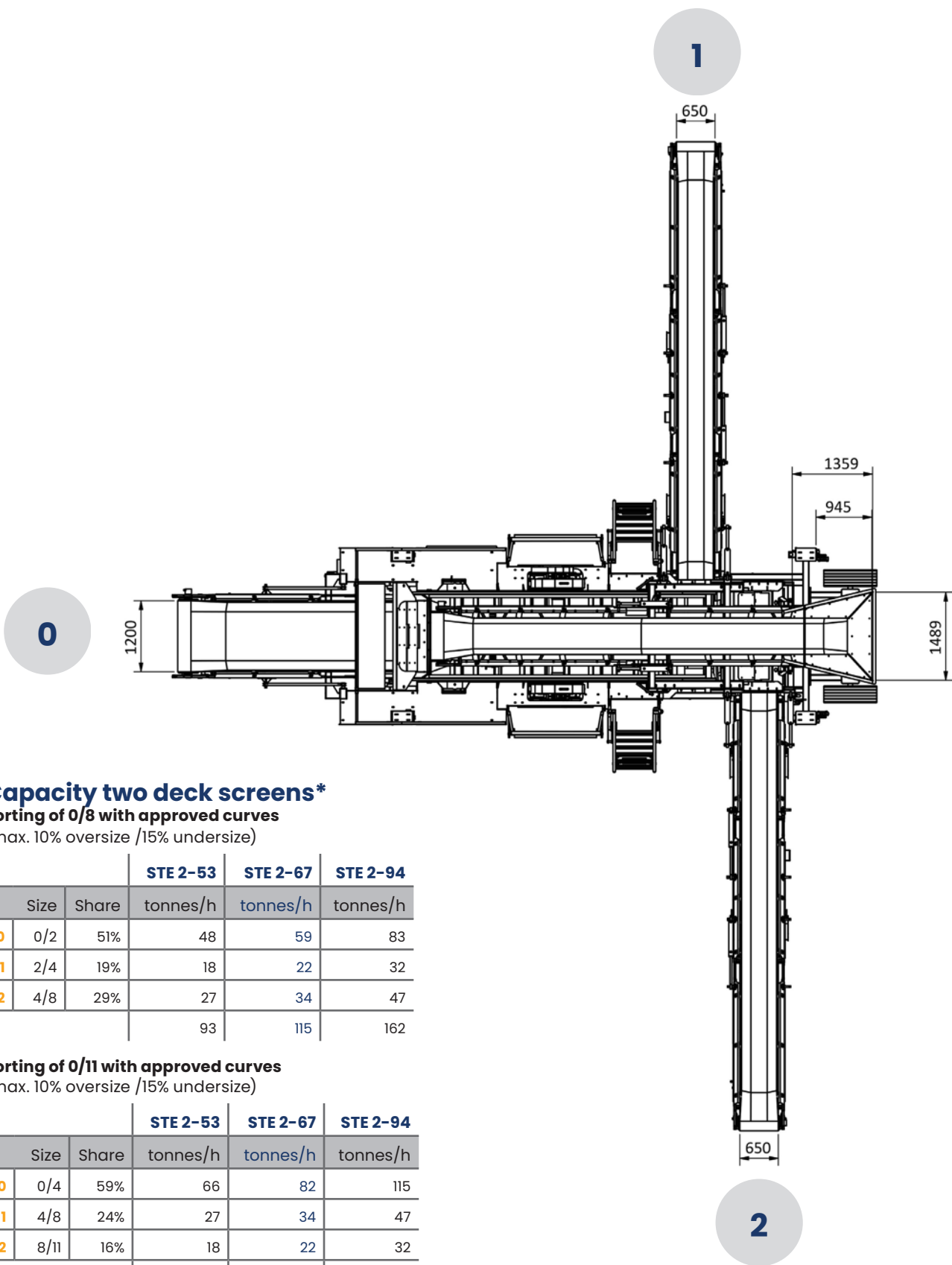

### Capacity two deck screens\*

Sorting of 0/8 with approved curves

(max. 10% oversize /15% undersize)

			STE 2-53	STE 2-67	STE 2-94
Size	Share		tonnes/h	tonnes/h	tonnes/h
0	0/2	51%	48	59	83
1	2/4	19%	18	22	32
2	4/8	29%	27	34	47
			93	115	162

Sorting of 0/11 with approved curves

(max. 10% oversize /15% undersize)

			STE 2-53	STE 2-67	STE 2-94
Size	Share		tonnes/h	tonnes/h	tonnes/h
0	0/4	59%	66	82	115
1	4/8	24%	27	34	47
2	8/11	16%	18	22	32
			111	138	194

Sorting of 0/16 with approved curves

(max. 10% oversize /15% undersize)

			STE 2-53	STE 2-67	STE 2-94
Size	Share		tonnes/h	tonnes/h	tonnes/h
0	0/4	51%	66	82	115
1	4/8	21%	27	34	47
2	8/16	28%	36	45	63
			129	160	225

\*These capacity examples are done in crushed granite, the performance in crushed concrete is similar

## Technical Specification Maskin Mekano SH 1202

<i>Transport Length</i>	9.5 m (31')
<i>Transport Width</i>	3.0 m (9.8')
<i>Transport Height</i>	3.2 m (10.5')
<i>Machine Weight</i>	approx. 18 tonnes, depending on equipment
<i>Screenbox</i>	STE 2-67 Screening surface 1.4 x 4.8 m (4.6 x 15.7') on two decks Single axle mechanically controlled with 12 mm stroke 11° incline Motor 11.0 kW, 400 V
<i>Feeding conveyor</i>	Belt width 800 mm (2.6') Length 7.0 m (23') Drum motor 5.5 kW, 1.25 m/s
<i>Mid size conveyor</i>	Belt width 650 mm (2.1') Length 9.0 m (29.5') Drum motor 4.0 kW, 1.0 m/s Height under the drum drive 4.4 m (14.4') (in elevated mode)
<i>Over size conveyor</i>	Belt width 650 mm (2.1') Length 9.0 m (29.5') Drum motor 4.0 kW, 1.0 m/s Height under the drum drive 4.4 m (14.4') (in elevated mode)
<i>Fines conveyor</i>	Belt width 1200 mm (3.9') Length 9.0 m (29.5') Drum motor 5.5 kW, 1 m/s Height under the drum drive 3.8 m (12.5') (in elevated mode)
<i>Catwalks and ladders</i>	Catwalks and ladders are hydraulically folded Access for changing the screening media provided behind the screen box
<i>Hydraulic equipment</i>	Hydraulic aggregate for folding of conveyors, stairs, and jacking legs. Motor 4.0 kW, 24 V pump
<i>Electric equipment</i>	Distribution box with integrated touchscreen and push buttons, safety breaker, safety disconnection breaker, emergency stop, preregulator as well as extra motor socket. Emergency stops also on conveyors and chassis. Power inlet with 125 A CEE-device
<i>Wheel- and towing device</i>	Hook-lift frame for transport as well as handling within the work site Optimized for easy trailer loading Hydraulic jacking legs for elevation to production mode

Our policy is one of continuous improvement and we reserve the right to change the detailed specification of our products at any time without prior notice.



# maskin mekano

Maskin Mekano AB, Box 9083, 550 09 Jönköping, SWEDEN,  
+ 46 36 31 74 00  
info@maskinmekano.se

[www.maskinmekano.se](http://www.maskinmekano.se)