

# TOP TOWER

THE FUTURE IS NOW



# TOP TOWER

Long-lasting roads and energy savings are the main considerations of road constructors today. The composite materials have to be suitable for all types of recycling and modern low-energy formulas, and at the same time they have to be adaptable to all recent technical developments for producing low cost asphalt.

These are the guide lines for the development of our complete range of new generation TOP TOWER asphalt plants.



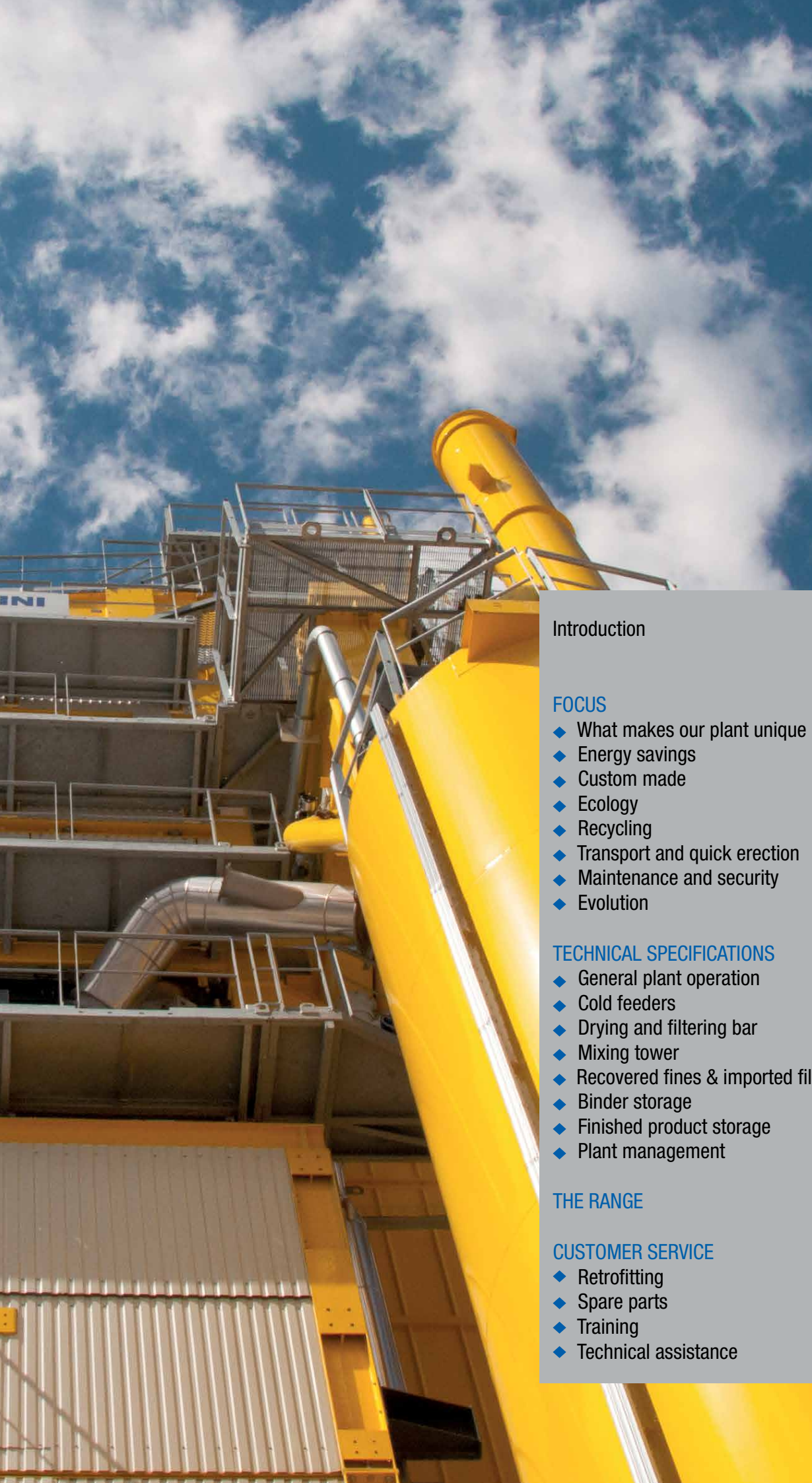

Introduction 02

#### FOCUS

- ◆ What makes our plant unique 04
- ◆ Energy savings 07
- ◆ Custom made 08
- ◆ Ecology 10
- ◆ Recycling 12
- ◆ Transport and quick erection 14
- ◆ Maintenance and security 15
- ◆ Evolution 16

#### TECHNICAL SPECIFICATIONS

- ◆ General plant operation 18
- ◆ Cold feeders 20
- ◆ Drying and filtering bar 21
- ◆ Mixing tower 22
- ◆ Recovered fines & imported filler circuit 23
- ◆ Binder storage 24
- ◆ Finished product storage 24
- ◆ Plant management 25

THE RANGE 26

#### CUSTOMER SERVICE

- ◆ Retrofitting 30
- ◆ Spare parts 31
- ◆ Training 31
- ◆ Technical assistance 31

# What makes our plant unique

## ENERGY SAVINGS

### **Our technology is your profit**

Whatever type of plant you have, the operational costs will be less.

High performance motors, insulation, reduction in heat loss, energy savings, CYB-\$AVE software for consumption control – these are some of the innovative solutions for making energy savings.

## ECOLOGY AND RECYCLING

### **The widest range of solutions available on the market**

A correct balance between ecology and profit thanks to four different solutions for use with RAP. Quality and high performance with the right investment.





## QUICK AND EASY ERECTION

### Quick erection accelerates productivity times and earnings

Pre-wired and tested modules, electric cabling above ground plus the possibility of steel foundations mean cost savings during erection and reductions in the overall costs of installation.

The surface space of the drum/filter bar is less than 30% when compared with the ground-based filter solution.

## MAINTENANCE AND SECURITY

### How to make a difficult job easy

Special long-life components, easy access to maintenance ports and the possibility of finding short-term solutions to problems help to maximise plant productivity whilst satisfying all safety regulations.

## EVOLUTION

### Ready to solve present and future problems

RAP technology can be easily implemented with low expenditure.

Low cost technical up-dating is available at all times. The plant is designed to use Warm Mix Asphalt technology which can be fitted at any point of time.





MARINI

MARINI

# Energy savings



## Environment

- the innovative concept of TOP TOWER means substantial savings in electric power and fuel consumption; in fact this plant results in a considerable reduction of CO<sub>2</sub> emissions
- the emission of fines into the atmosphere is in line with the most recent environmental specifications
- the mixing tower is insulated and cladded to eliminate heat loss, fines emissions and noise pollution
- the overall ground surface area is greatly reduced when compared with traditional plants

## Energy savings

- gas and recovered fines circuits are optimised thanks to the positioning of the filter above the dryer drum and the new dryer tower concept
- reduced heat loss of exhaust gases thanks to shorter dryer-filter connection; burner consumption is significantly reduced
- the fines are recovered by gravity in the hopper under the filter, near the weigh hopper with consequent reduction in the length of the screw conveyor and the electric power required. The recovered fines fall into a warm air environment and are fed into the final mix at the highest possible temperature
- the screen with hopper underneath are insulated and panel-lined, to cut down on heat loss



# Custom made



*In the global world with its continual research into standardizing every single product, MARINI remains true to form and goes against the grain.  
Customer satisfaction is its aim. How? By making every individual client feel UNIQUE.*

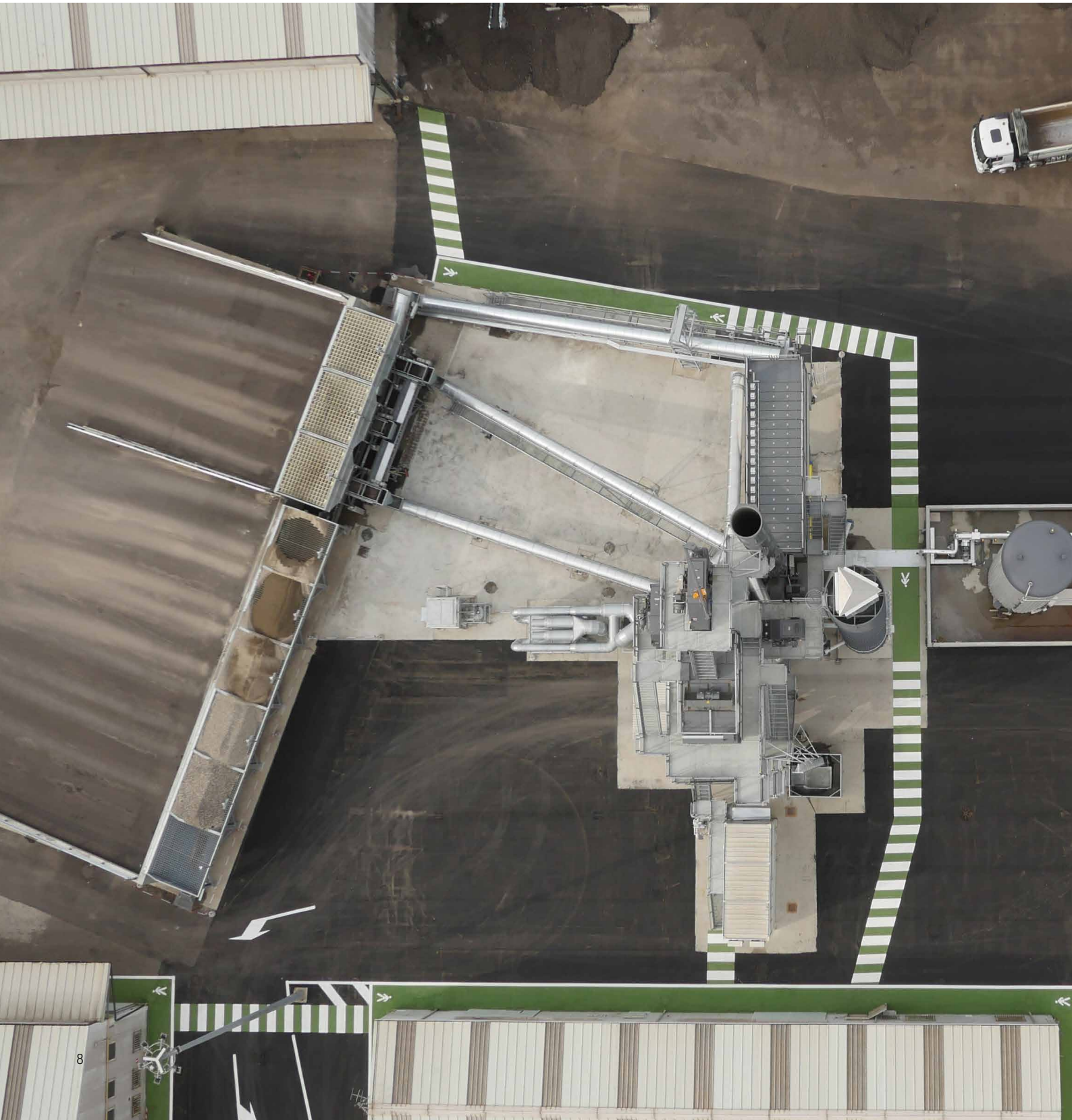



MARINI puts highly professional experienced sales and technical staff into the field, together with a service team to accompany the plant throughout its working life.

This is the reason why every MARINI plant becomes a unique, personal and exclusive product which can satisfy all the requirements of each and every customer in terms of operational flexibility and plant performance, together with the Italian DESIGN which makes all our asphalt plants stand out!

# Eco friendliness



*Regard for the environment is essential in our society. MARINI is especially sensitive to eco friendliness, which can be seen in the development of their new fumes treatment system (capturing, filtering and heat treatment).*



At the end of the asphalt production process, when the new mix comes into contact with the atmosphere, the vapours released may have the characteristic smell of bitumen.

These emissions can be classed into 2 types:

- **conveyed emissions** which are caused by the drying and mixing phases and are characterised by defined points of emission with limit values that depend on the type of asphalt being produced
- **diffuse emissions** which are generated during the loading and unloading stages and during other secondary phases in plant operation, and although there is no specific point of measurement the emissions can be reduced using specific collection technologies.

In order to eliminate the diffuse emissions, a special exhaust system can be fitted to convey the fumes into the stack which is the only exhaust point on site. To make the process effective, the exhaust must be effected at the moment the fumes are generated and as near as possible to the emission points.

The vapours produced by the bitumen tanks and those generated during tanker discharge can be collected and processed with specific systems of carbon active treatment designed and produced by MARINI.

### Fumes cleaning and treatment

MARINI has developed and successfully fitted AeroFILTER, a new filtering system for fumes and blue smokes produced at certain points of the plant, such as the mixer discharge or along the skip track if the plant is fitted with a lateral storage bin plus the truck discharge points.

Filtering takes place in a series of steps and the oils are recovered in the lower part of the hopper before being evacuated through special tanks, without any external dispersion.

The treated fumes can be sent to the stack of the plant or receive further heat treatment in the MARINI EvoDRYER.

The new technology, combining the AeroFILTER with the use of the EvoDRYER system, is called ZEROVOC and results in effective and efficient fumes management plus treatment of VOC emissions.

This product, which is available at a very affordable price, is compact in terms of space but extremely effective in terms of filtering capacity and performance, making it an essential part of the plant.

### Heat treatment of the fumes

As well as the benefits and improved performance with RAP use, the new EvoDRYER system also provides heat treatment of the fumes which could contain classified substances such as VOC.

The conveyed air is fed behind the burner flame through a special cylinder entrance.

This patented system means the air is distributed around the external periphery of the combustion chamber where the fumes are quickly and effectively treated and the residual organic composites of the gases are eliminated.



# Recycling



Over the years there has been a growing interest in the use of recycling which can no longer be considered an optional.

Throughout the world, specialists are working towards recycling for a series of reasons:

- reduction of waste resulting from the degrading of the road network
- elevated amounts of RAP with problems of storage
- reuse of raw materials, since there is a lack of aggregates due to the decreasing number of active

quarries at national and international level

- energy savings, since consumption is lowered due to the reduction in aggregate quarrying, transportation and traffic hold-ups
- bitumen recycling, because not just aggregates are reutilized, but also the binder is recuperated in part

## Recycling ring

The position of the recycling ring after the flame means RAP can be fed at the ideal point of the dryer drum without any infiltration of parasitic cold air. RAP does not enter into direct contact with the hot gases of the burner flame, but is gradually heated in the drum through heat-recovery flights and mixed with the virgin aggregates which have been heated up to a suitable temperature. In this way the risk of damaging the bitumen is avoided, which is the most considerable advantage of this technology.

## Recycling into mixer

The feeding of RAP can be made directly into the mixer through a special feed line which consists of:

- cold feeder and belt
- cold RAP metering unit with bucket elevator, surge hopper, weigh belt with variable RAP feed management, depending on moisture content
- modular exhaust system for RAP produced in the mixer with stoppage of fumes from drum to filter

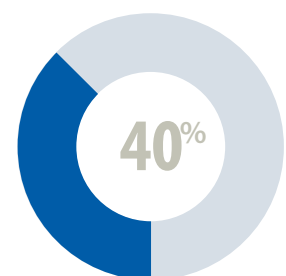
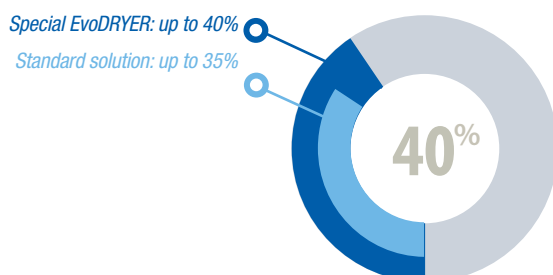



### Combined technology: ring + mixer

A combination of the two technologies mentioned above proves to be the best technical solution in terms of flexibility and performance when using RAP.



### Recycling in parallel drum

The RAP is dried and heated in a specially designed drum. Various technologies are available which allow both the increase of RAP percentages and the decrease of plant emissions.

Naturally each solution has a balance between expected performance and level of investment.

The line consists of:

- cold feeders and feed belt
- bucket elevator and RAP dryer drum

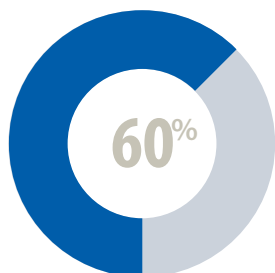

*Hot air generator: up to 90%*

*Full recycling technology: up to 80%*

*Equi-flow parallel drum: up to 70%*

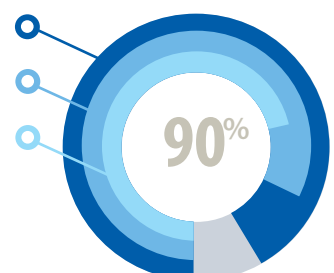

# Transport and quick erection

The modular concept of the plant with its pre-wiring system greatly facilitates transport and speeds up the erection time of the component parts.

Plant ergonomics have been studied to improve comfort and ensure maximum safety for the operators.

## Transport and quick erection

- plant models TOP TOWER 2000, 2000 P, 2500 are fully container-loaded for quick, affordable and safe transport
- steel supporting bases mean the plant can be erected on stabilised ground ( $2,5 \text{ kg/cm}^2$ ) without cement foundations, resulting in easy transfer
- all mixing tower cabling is an integral part of the structure and walkways

## Erection sequence

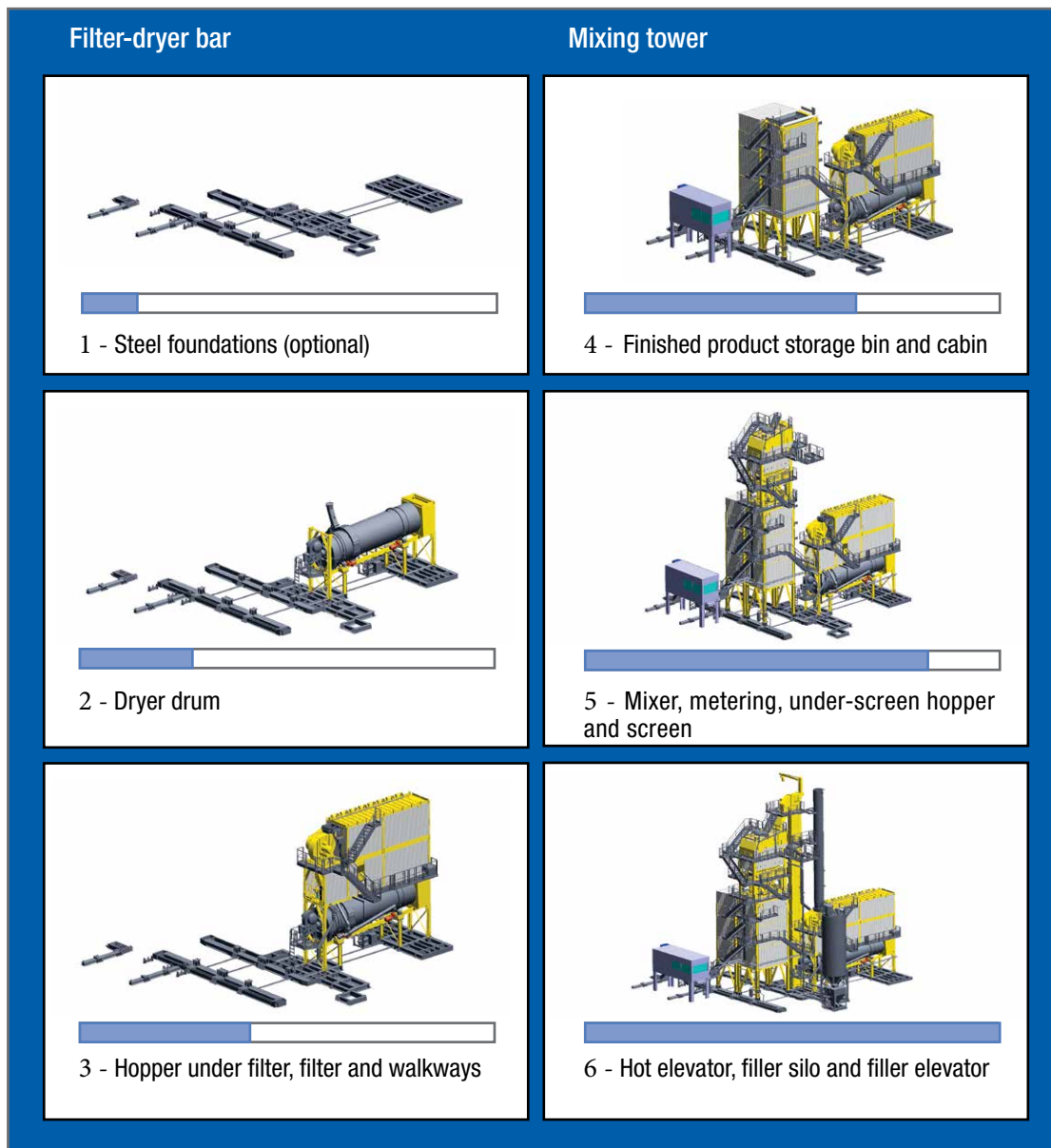

# Maintenance and safety



*The entire TOP TOWER range has components which are built to last and facilitate maintenance operations thanks to professional design, choice of high-quality materials and scrupulous assembly.*

The plant is built in accordance with international law and the most stringent technical regulations in the sector. It is fitted with high-performance safety devices to guarantee the well-being and safety of the operators at all stages of work, including maintenance operations.

All plants have good-sized access ports for maintenance (up to 600 mm wide) and the majority have centralized grease points to optimize and reduce maintenance operations.

## Assisted maintenance

- arms and paddles with bolted anti-wear components
- symmetrical paddle shape
- bolted anti-wear plates on mixer bottom, made from special highly resistant cast iron
- special anti-wear plates (optional) to increase life of components subject to abrasion (up to 6 times)
- easy replacement of screen grills thanks to patented system to reduce dismantling and assembly time
- two ample access points (with integrated by-pass)
- quick adjustment of dryer drum thanks to easy regulation of rolling rings

## Improved ergonomics

- optimum plant layout to simplify vehicle movement on site
- electric cabinets fitted in spacious cabin, with complete view of site
- ladders and catwalks for access to all points of plant
- ample access ports for easy and safe movement

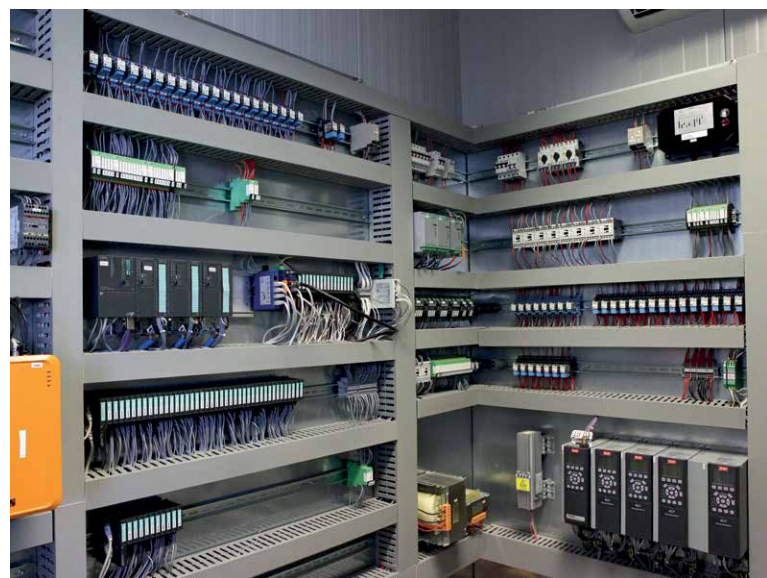

# Evolution

*The plant's innovative design allows the use of all types of additive in order to manufacture a wide range of asphalts. A special kit (optional) can be fitted to the plant at any time.*



TOP TOWER plants can work with:

- **cellulose fibres:** highly fibrillated cellulose pellets, designed to increase stabilization of the asphalt mix
- **pigments:** iron oxide, yellow blue and white colorants
- **bitumen polymer modifiers** (Cera, EVA, SBS, Latex)
- **neutral binder:** synthetic asphalt binder for special colouring flexibility
- **rubber crumb:** high quality recycled car and truck tyres for better binder elasticity and lower thermal

sensitivity - reducing deformation, road vibration, noise pollution and moisture damage

- **adhesion modifier:** in liquid and pellet form for improved bitumen-aggregate bonding
- **clear synthetic binder:** for greater colour flexibility and brightness of road mat



Warm Mix Asphalt (WMA) is already the asphalt mix of tomorrow. Most commonly produced at 30°C below Hot Mix Asphalt (HMA) temperatures, WMA ensures high mechanical performances similar to those of HMA, while providing a whole range of benefits:

- reduction of bitumen VOC emissions
- reduction of CO<sub>2</sub> (carbon dioxide) and other gas emissions due to energy savings when drying and heating virgin aggregates
- reduction of fumes, emissions and odours
- faster opening to traffic
- higher workability
- better compaction performances and extension of paving season
- delivery of asphalt mix to longer distances
- reduction of energy consumption = low production cost
- higher plant recycling performances



*Foaming system*

Water based WMA technology is the best performing solution, especially the micro-bubbled foam bitumen solution (with high pressure water) which offers the widest range of technical and economical advantages.

#### **Foaming system: easily fitted kit**

Based on the long experience of the Fayat Mixing Plant division (FMP) in this field, the foaming system has proved to be the best performing equipment for producing higher quality foam bitumen with the micro-bubble method and low water percentage in the bitumen.

It consists of:

- a unit for pressurized water metering
- a foaming gun for injecting water into the bitumen feed
- total integration of the system into the main plant software for new plants or into independent panel for retrofitted plants

# General plant operation



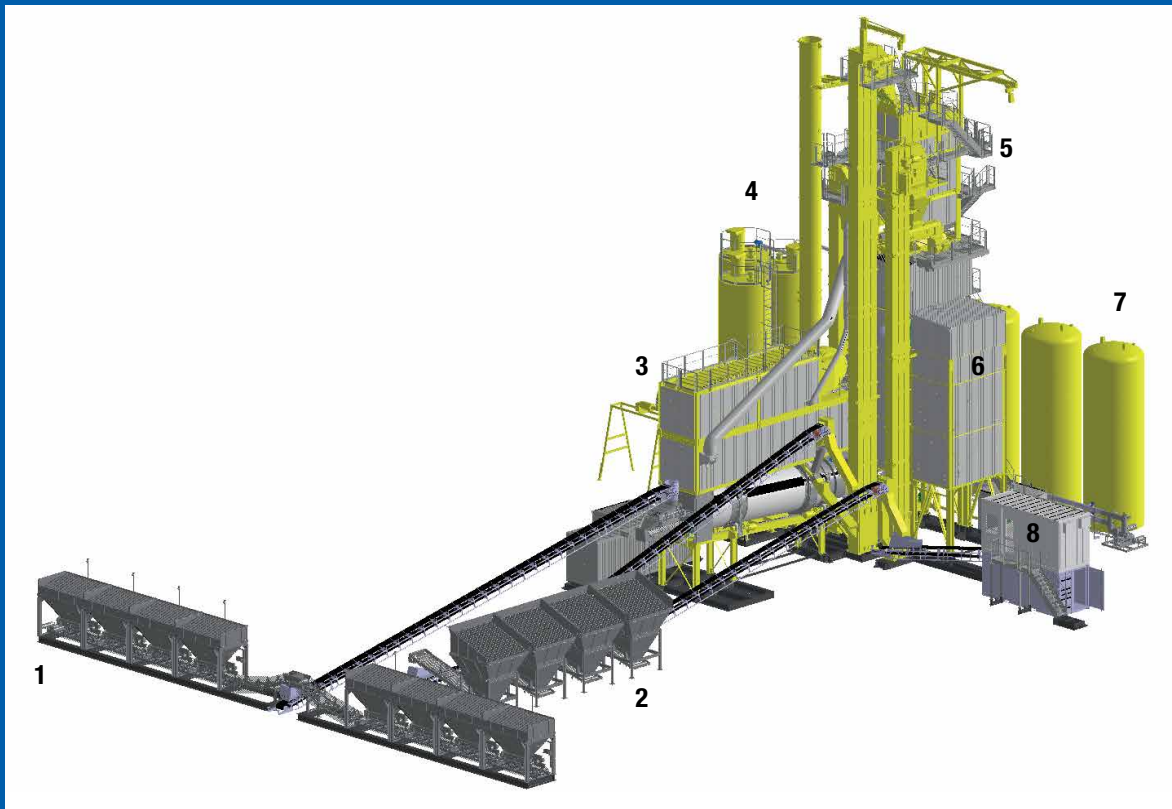

**1** storage and metering of virgin aggregates

**2** storage and metering of RAP

**3** dryer tower

- dryer drum and recycling ring
- recovered fines storage under filter
- bag filter

**4** Imported fines storage

**5** mixing tower

- hot elevator
- fines elevator
- screen
- hopper under screen
- metering of components
- mixer

**6** storage bin

**7** binder storage

**8** control cabin and automation



## Cold feeders

*Storage and metering of the materials with re-composition of the grading curve.*

### Hopper

- Base capacity/loading width  
11m<sup>3</sup> / 3.5 m  
18 m<sup>3</sup> / 3.5 m  
20 m<sup>3</sup> / 4.0 m
- from 1 to 15 hoppers
- increased capacity available upon request

### Features

- preset synchronised extraction capacity for individual extractors
- LED indicators for extractor operations and hopper reloading
- reduced loading height

### Extractor

- volumetric metering
- capacity 6 - 150 t/h

### Options \*

- weigh extractor
- anti-adherent lining
- protection grills
- steel foundations
- cold feeder covering

# Drying and filtering bar

*The filter is positioned directly above the dryer drum. Optimum gas and material flows, rationalized ground space requirements, facilitated vehicle circulation.*



## High performance counter-flow dryer drum

- shape and location of flights optimizes heat exchange between combustion gases and aggregates
- quick and easy adjustment of drum position

## Burner

The burner/dryer unit is designed for maximum thermal performance: energy consumption is optimized and CO<sub>2</sub> emissions limited

- suitable for all types of fuel available on market: diesel fuel, dense oil, natural gas, lignite dust

## Filter and storage hopper

### Filter

- the elliptical shape of the aramid bags means reduced volume, with consequent reduction of the overall size of the filter, while maintaining the same filtering capacity as circular models

### Recovered fines hopper

- the hopper is situated directly under the filter, meaning the fines are collected by gravity and then reintroduced into the mixing process

# Mixing tower

*Thanks to more ample, comfortable access and a new patented system for the rapid replacement of the screen meshes, tower maintenance has never been easier. Gravity metering of the binder is a new additional feature of TOP TOWER.*



## **Vibrating screen with 5 or 6 meshes and direct discharge**

- lateral position of by-pass does not impede access to screen meshes, but guarantees easy maintenance
- easy and quick replacement of meshes (patented method)

## **Bitumen metering**

The metering of the bitumen by gravity means the type of binder can easily be changed, without wasting time and materials.

## **Mixer**

Reliable and high-performing, thanks to the honeycomb paddles and well-designed seal system.

Versatile:

- designed for use with all types of additives
- fitted with system for removal of water vapour

Reliable:

- support bearings and seals of the shafts located internally, for easy maintenance access and unequalled durability

# Recovered fines and imported filler circuit

*The concept of the dryer bar optimizes the recovered fines circuit.*

## Recovered fines circuit

Given that the bag filter is positioned immediately above the drum, the fines can be recovered in the hopper through gravity, making their journey as short as possible and allowing the fines to be re-fed into the mix without any heat loss.

The pre-separator integrated into the filter means the larger fines can be recovered and then reintroduced into the formula directly at the dryer drum exit.



## Binder park

*Binder parks are designed to guarantee the loading of tanks and supply to the plant in total safety. Both vertical and horizontal, with electric or hot oil heating, the tanks allow all types of binder (hydro carbonic and synthesis types) to be stored.*



## Finished product storage

*The storage silos can have a variety of capacities and configurations to satisfy all site requirements. Their design allows up to three modules to be combined, side-by-side or stacked.*



# Plant management

*The coordination of production efficiency together with plant maintenance and safety must be guaranteed by an adequate management system - the new Marini Cybertronic system.*

**Ergonomics, safety and ecology in the simplest of control methods:**

- Integrated Diagnostic System (IDS) for a quick and simple identification of possible procedural errors
- innovative graphic design, easy to understand, real time plant visualization
- wide range of operational languages which can be customized
- client training programme for improved competency
- dual monitor control system (upon request)

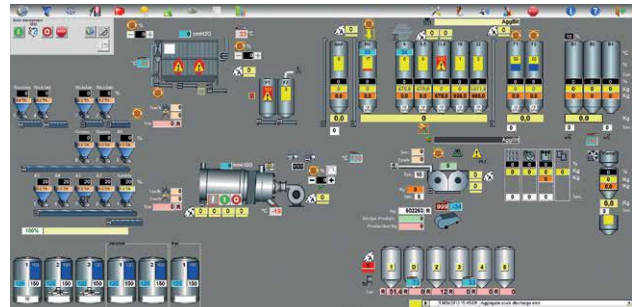

**Plant components management:**

- **production planning:** automatic production cycle planning for optimum results
- **maintenance module:** automatic non-stop management of maintenance activities of individual components
- **calibration management system:** specific integrated system for efficient calibration of plant components and extractors
- **binder park management system:** control of loading, storage and decanting to ensure the product's total integrity
- **WMA production management:** automatized management module for WMA production with foaming system
- **CYB-R@P module:** automatic RAP and virgin material modification with regard to customer requirements
- **interface with weigh bridge:** weighing operations automatically connected to planning operations

**In addition:**

- **CYB-SAVE module:** control system for containing energy consumption and limiting environmental footprint
- **geo-tracking system:** accurate geo-location of customer system of logistics
- **worldwide online service:** remote connection to MARINI plants with 24/7 hotline support for rapid technical intervention



# TOP TOWER : range up to 200 t/h

Type	TT 2000	TT 2000 P	TT 2500	TT 2500 P
<b>MAX production</b>	<b>160 t/h</b>		<b>200 t/h</b>	
Nominal production 3% moisture	160 t/h		200 t/h	
Nominal production 5% moisture	120 t/h	160 t/h	180 t/h	200 t/h
Cold feeders: capacity and number	at customer request			
Dryer drum	E180 (L=8.5 m/D=1.8 m)	E206 (L=8.5 m/D=2.06 m)		E220 (L=9 m/D=2.2 m)
Burner power	9 MW	13.4 MW		16.8 MW
Hopper under filter (only recovered fines)	22 t	25 t		
Filtering surface	525 m <sup>2</sup>	663 m <sup>2</sup>		750 m <sup>2</sup>
Total screen surface	16.5 m <sup>2</sup> / 20.8 m <sup>2</sup>		26.9 m <sup>2</sup> / 32.1 m <sup>2</sup>	
Compartments under screen	4 ( 5 optional) + 1 by-pass		5 ( 6 optional) + 1 by-pass	
Storage capacity under screen	22 t / 53 t			
Mixer capacity	2 t		2,5 t	
Imported filler storage	at customer request			
Binder storage	at customer request			
Product storage / compartments	- direct discharge - under mixer: 30 t in 1 compartment 2 x 30 t in 2 compartments 2 x 70 t in 2 compartments - lateral silo: 2 x 30 t in 2 compartments 36 + 45 t in 2 compartments (option up to 221 t) (on request load cells / long life silo)			
Recycling up to 40%	Special MARINI metering system for high % in mixer			
Recycling up to 40%	Recycling ring			
Recycling up to 60%	Ring + mixer combination			
Recycling up to 90%	-		Parallel drum	



# TOP TOWER: range up to 260 t/h

Type	TT 3000	TT 3000 S	TT 3000 P
<b>MAX production</b>	<b>240 t/h</b>	<b>260 t/h</b>	
Nominal production 3% moisture	200 t/h	250 t/h	
Nominal production 5% moisture	180 t/h	200 t/h	250 t/h
Cold feeders: capacity and number	at customer request		
Dryer drum	E220 (L=9 m/D=2.2 m)		E250 (L=10 m/D=2.5 m)
Burner power	13.4 MW	16.8 MW	19 MW
Hopper under filter (only recovered fines)	25/70 t		40/80 t
Filtering surface	750 m <sup>2</sup>		1012 m <sup>2</sup>
Total screen surface	27.2 m <sup>2</sup> / 32.6 m <sup>2</sup>	32.0 m <sup>2</sup> / 38.4 m <sup>2</sup>	
Compartments under screen	5 ( 6 optional) + 1 by-pass		
Storage capacity under screen	25 t / 60 t		
Mixer capacity	3 t	3 t / 4 t	
Imported filler storage	at customer request		
Binder storage	at customer request		
Product storage / compartments	- direct discharge		
	- under mixer		
	30 t in 1 compartment 2 x 50 t in 2 compartments up to 320 t in 6 compartments - lateral silo from 126 t in 2 compartments up to 504 t in 8 compartments (on request load cells / long life silo)		
Recycling up to 40%	Special MARINI metering system for high % in mixer		
Recycling up to 40%	Recycling ring		
Recycling up to 60%	Ring + mixer combination		
Recycling up to 90%	Parallel drum		

# TOP TOWER: range up to 360 t/h

Type	TT 4000	TT 4000 S	TT 4000 P	TT 5000
<b>MAX production</b>	<b>320 t/h</b>			<b>360 t/h</b>
Nominal production 3% moisture	280 t/h	320 t/h		360 t/h
Nominal production 5% moisture	250 t/h	280 t/h	320 t/h	360 t/h
Cold feeders: capacity and number	at customer request			
Dryer drum	E250 (L=10 m/D=2.5 m)		E270 (L=11 m/D=2.7 m)	
Burner power	19 MW	22 MW	24 MW	27 MW
Hopper under filter (only recovered fines)	40 t / 80 t		70 t	
Filtering surface	1012 m <sup>2</sup>		1280 m <sup>2</sup>	1300 m <sup>2</sup>
Total screen surface	37 m <sup>2</sup> / 45m <sup>2</sup>	48.2 m <sup>2</sup> / 58.5 m <sup>2</sup>		
Compartments under screen	5 ( 6 optional) + 1 by-pass			
Storage capacity under screen	line up of hoppers: 25 t / 80 t / 140 t – double line of hoppers: 2 x 100 t			
Mixer capacity	4 t	4 t / 5 t		5 t / 6 t
Imported filler storage	at customer request			
Binder storage	at customer request			
Product storage / compartments	- direct discharge			
	- under mixer			
	30 t in 1 compartment			
	2 x 50 t in 2 compartments			
	2 x 90 t in 2 compartments			
	up to 600 t in 6 compartments			
	- lateral silo			
	from 126 t in 2 compartments up to 504 t in 8 compartments			
	(on request load cells / long life silo)			
Recycling up to 40%	Special MARINI metering system for high % in mixer			
Recycling up to 40%	Recycling ring			
Recycling up to 60%	Ring + mixer combination			
Recycling up to 90%	Parallel drum			





# After sales service

*Innovation. Everywhere. With you. Complete customer satisfaction lies at the heart of our job and this requires a superior after sales service. MARINI can boast a high-quality service, backed up by an expert team of professionals who are at the constant service of the customer.*

## Retrofitting

Retrofitting gives new life to all site components and increases plant efficiency, even with regard to the strictest of new eco standards

- **up-grading:** gradual integration of new competitive technologies into existing plants
- **replacement:** substitution of obsolete solutions / dated or well-worn components
- **ecology:** implementation of RAP / WMA technologies and treatment of emissions
- **consultancy:** expert teams of specialists ready to collaborate with customers to identify the necessary modifications
- **not just MARINI:** ability to integrate MARINI technologies and components into asphalt plants of all brands

## Spare parts

A quality service for all plant types, based on 120 years of MARINI experience

- **highly qualified teams:** professional MARINI staff offer their vast expertise to identify and supply the necessary parts
- **out of stock parts:** ability to trace spares which are currently out of stock or find alternative solutions
- **stock management:** optimum stock control to ensure more than 80% availability of original spare parts
- **long-life guarantee:** original MARINI spare parts designed to guarantee superior durability when compared with cheaper alternatives
- **widespread market presence:** availability of a vast sales network which is in continual expansion
- **last minute shipments:** two daily shipments (plus last minute) with express service and special transport. Special Saturday and Sunday morning shipments upon request





## Training

MARINI is aware of the importance of well-prepared, competent staff who can ensure the efficiency and productivity of the plant and exploit its potential to the full.

It offers the customer a comprehensive training programme, held either in the modern Marini Training Academy or directly on site

- **foundation course for plant operators:** basic training for safe and better asphalt production with MARINI plants
- **burner management course:** basic concepts for burner management to reduce consumption and improve product margins
- **software course:** training programme for increasing awareness and competence when using MARINI software
- **maintenance course:** basic concepts for ordinary maintenance of MARINI plants with the aim of reducing down-time

## Technical assistance

The “Marini Service” programme guarantees continual support for its plants worldwide. This is possible thanks to a team of constantly up-dated technicians and local Marini partners. Consultancy, support and rapid intervention, even at long distance, are at the heart of “Marini Service”, with the aim of establishing beneficial, long-lasting customer relationships based on:

- **quality:** rapid and reliable action in all services thanks to MARINI's competence and experience
- **erection:** supervision of all assembly stages to ensure total adherence to budget plans and time scales
- **testing:** customer support during final plant testing to guarantee optimum installation
- **maintenance:** regular inspections and programme planning for custom-made preventive maintenance
- **support H24/7 :** long-distance customer assistance and support around the clock, with qualified staff ready to respond to all demands

**MARINI SpA**

Via Roma, 50  
48011 Alfonsine (RA)  
ITALY  
Ph.: +39 0544 88 111  
Fax: +39 0544 81 341  
info@marini.fayat.com  
www.marini.fayat.com

**MARINI CHINA**

20, Huaxiang Road  
Langfang  
Economic and Technical  
Development Zone  
Hebei 065001  
CHINA  
Ph.: +86 (0)316 608 7001  
Fax: +86 (0)316 608 7002  
info@marini.com.cn  
www.marini.com.cn

**MARINI INDIA PVT LTD**

AV/39-40-41 GIDC,  
Sanand - Industrial Estate II,  
BOL, Sanand Ahmedabad  
382110 - Gujarat  
INDIA  
Ph.: +91 (0)75 7485 2816  
support@marini.co.in  
www.marini.co.in

**MARINI MAKINA A.Ş.**

N: 10 06930  
1. OSB Kırım Hanlığı Caddesi  
Cad. Sincan  
Ankara  
TURKEY  
Ph.: +90 (312) 386 33 22  
Fax: +90 (312) 386 33 23  
info@marini.com.tr  
www.marini.com.tr

**FAYAT MIDDLE EAST FZE**

Jafza South  
FZS1AH03 Dubai  
U.A.E.  
Ph.: +971 (0)4 8863233  
Fax: +971 (0)4 8863234  
marinime@emirates.net.ae  
www.marini.fayat.com



This is not a contractual document and reference should be made to individual offers. The manufacturer reserves the right to make modifications at any time (03/2018)

