

LSM • PUMPER



ATLANTIC
PUMPS

MOVING WHAT MATTERS

OFFICIAL UK DISTRIBUTOR
FOR LSM PUMPS

Atlantic Pumps are the
official UK distributor for

LSN • PUMPER



LSM Pumps are a Danish based company and are a key player in the peristaltic pumps market. Their pumps are used globally and are known for their low energy consumption, low and easy maintenance and their exceptional build quality.

LSM produce a range of different sizes of peristaltic pump ranging from common sizes such as the LSM-25 (1") up to the LSM-200 (8") model – recognised as being the largest peristaltic pump in the world.



What is a peristaltic pump and how do they work?

Peristaltic pumps, also known as hose pumps, are a type of positive displacement pump. The main components of an LSM hose pump are the pump casing, the hose and the rotor.

When the rotor turns, the rollers on the rotor squeeze the hose flat. In front of the roller, pressure builds up and because of the hose's elasticity a vacuum builds up behind the roller. The pressure pushes the fluid out of the hose and the vacuum sucks the new fluid in.

Where are they used?

LSM pumps are used in a wide range of industries and applications across the globe.

Examples include:

- Food
- Mining
- Chemical
- Fishing
- Agriculture
- On and off shore
- Anaerobic digestion/biogas
- Concrete
- Paint

LSM pump advantages

- It is reversible. Depending on what the rotation direction is set to, the inflow and outflow for the pump can be either at the top or at the bottom.
- It is self-priming
- Easy to service
- The pump contains very few moving parts
- Can run dry
- Low energy consumption compared to other pumps. The glycerine in the pump casing lubricates the hose and the rollers in the pump, which results in a very low energy consumption.
- The pump is sealed and protected against back flow, even when it is not in operation as the rollers always push the hose flat.
- Good hygiene. Only the hose is in contact with the fluid which is being pumped. Bearings and gaskets are not affected. Abrasive fluid does not affect the pump.
- Solid objects can to a certain extent pass through the hose. Depending on the hose's diameter, it is possible to handle foreign objects such as sand, pebbles and similar. It can even handle fish up to a certain size, without damage.
- Is suitable for fluids with a high viscosity and a high dry matter content.





LSM pump options

LSM model	10	15	25	32	40	50	65	80	100	125	150	200
Hose diameter	1/4"	1/2"	1"	1 1/4"	1.5"	2"	2.5"	3"	4"	5"	6"	8"
LSM pump versions												
Plastic (PP)	•	•										
Stainless steel (AISI304)			•	•	•	•	•	•	•			
Steel (coated / lacquered)			•	•	•	•	•	•	•	•	•	•
Upgrades to the LSM pump:												
Electric control								•	•	•	•	•
ATEX	•	•	•	•	•	•	•	•	•	•	•	•
Heavy duty version									•	•	•	•
Additions for LSM pumps												
Stainless steel screen over gear / motor			•	•	•	•	•	•	•	•	•	•
Operational monitoring	•	•	•	•	•	•	•	•	•	•	•	•
Vacuum pump								•	•	•	•	•
Air expansion vessel			•	•	•	•	•	•	•	•	•	•
Pulsation damper	•	•	•	•	•	•	•	•	•	○	○	○
Coating of connecting pipes	•	•	•	•	•	•	•	•	•	•	•	•
Frequency converter	•	•	•	•	•	•	•	•	•	•	•	•
Pipes, fittings etc.	•	•	•	•	•	•	•	•	•	•	•	•
Installation, mounting etc.	•	•	•	•	•	•	•	•	•	•	•	•

• Possible ○ On Request

Technical data

	LSM10	LSM15	LSM25	LSM32	LSM40	LSM50
Flow	105 l/h	230 l/h	1 m3/h	2 m3/h	3 m3/h	6 m3/h
Revolutions	35 rpm/min	35 rpm/min	28 rpm/min	28 rpm/min	28 rpm/min	28 rpm/min
Max pressure	15 bar	15 bar	15 bar	15 bar	15 bar	15 bar
	LSM65	LSM80	LSM100	LSM125	LSM150	LSM200
Flow	12 m3/h	20 m3/h	40 m3/h	60 m3/h	120 m3/h	300 m3/h
Revolutions	26 rpm/min	26 rpm/min	26 rpm/min	26 rpm/min	26 rpm/min	26 rpm/min
Max pressure	15 bar	15 bar	15 bar	15 bar	15 bar	15 bar

The technical specifications mentioned in the table are based on our standard setup. It is possible to vary the required flow by changing the revolutions.

Dimensions of LSM pump variants

Model:	Measurement A	Measurement B	Measurement C	Measurement D1	Measurement D2	Weight	Motor:
LSM-10	338mm	270mm	470mm	89mm	212mm	25kg	0.18kW
LSM-15	340mm	270mm	476mm	93mm	304mm	25kg	0.37kW

Drawing Example

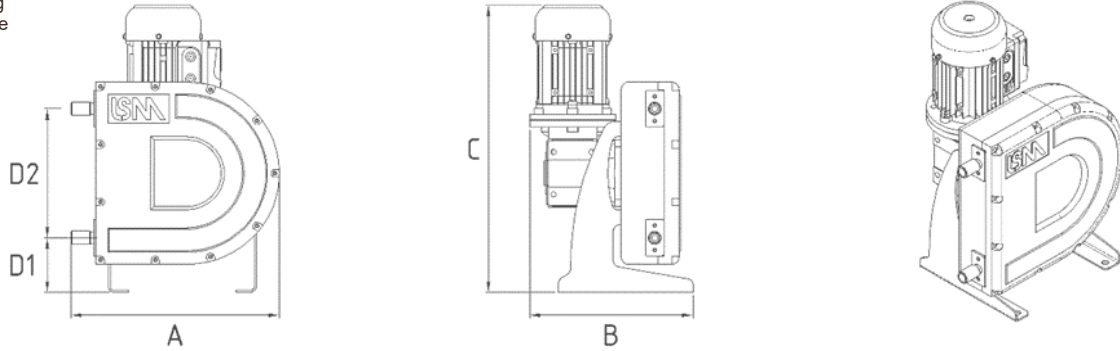

Model:	Measurement A	Measurement B	Measurement C	Measurement D1	Measurement D2	Weight	Motor:
LSM-25	510mm	543mm	543mm	137mm	336mm	65kg	0.37kW
LSM-32	640mm	531mm	675mm	162mm	436mm	105kg	0.55kW
LSM-40	781mm	670mm	771mm	160mm	520mm	140kg	0.75kW
LSM-50	889mm	788mm	895mm	195mm	594mm	250kg	1.5kW
LSM-65	1040mm	910mm	1040mm	201mm	720mm	400kg	2.2kW
LSM-80	1260mm	1063mm	1211mm	235mm	860mm	500kg	4.0kW

Drawing Example

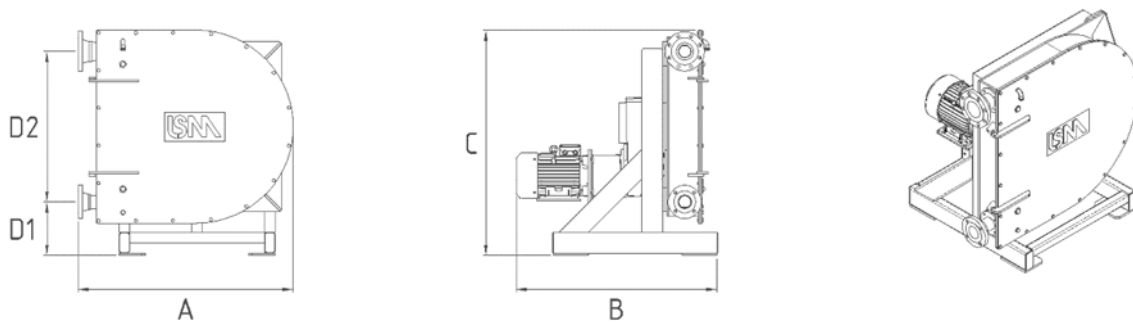

Model:	Measurement A	Measurement B	Measurement C	Measurement D1	Measurement D2	Weight	Motor
LSM-100	1472mm	1156mm	1642mm	367mm	1090mm	700kg	7.5kW
LSM-125	1743mm	1455mm	1816mm	410mm	1205mm	1,300kg	11kW
LSM-150	1953mm	1561mm	2132mm	461mm	1420mm	1,800kg	15/18kW
LSM-200	2744mm	1944mm	2909mm	527mm	1970mm	4,500kg	37/45kW

Drawing Example

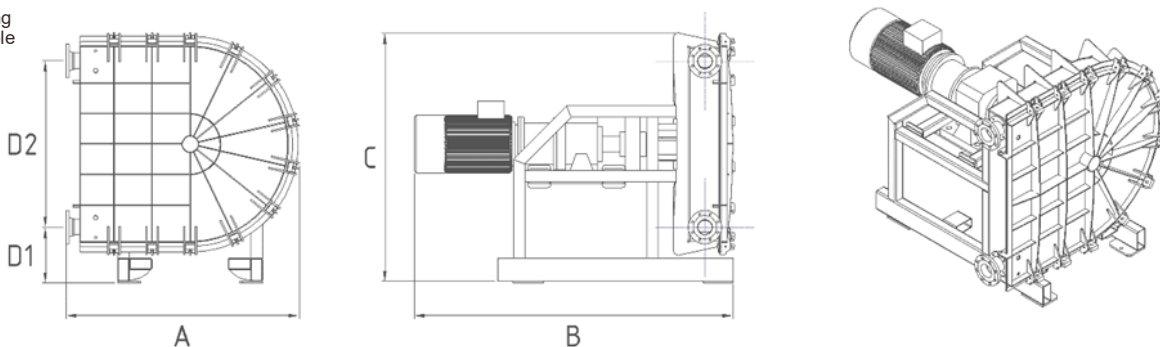

Please note: Deviations of dimensions may occur



ATLANTIC
PUMPS

T: +44 (0)1246 284 420

E: hello@atlantic-pumps.com

W: atlanticpumps.co.uk

Copyright © 2026 Atlantic Pumps Limited. All rights reserved.
Atlantic Pumps Ltd is registered in England company number: 09400148. VAT Number: 249459267.
Registered Office: Atlantic Pumps, Carrwood Road, Chesterfield, Derbyshire, United Kingdom, S41 9QB.