



KUTAVAR



KUTAVAR





About Us

KUTAVAR is a high precision, high performing, robust CNC plasma machine, designed to be simplistic and intuitive.

A British company with in-house design, manufacturing, and assembly.

Having been established for over two decades in the design and supply of CNC plasma cutting machines, KUTAVAR is at the forefront of delivering premium solutions to its market sector.

Our Team consists of highly skilled design and service engineers, located at our UK premises in Herefordshire.

Product innovation and expansion in the range of machines is at the strategic forefront of the company, as KUTAVAR continues to expand.





Design

KUTAVAR is designed to push the boundaries of the market sector it sits within, simply by introducing component design and tolerances that are unrivalled, only present in larger-scale machinery sectors.

KUTAVAR has been designed to micron (μm) tolerances, not millimetres. Components are precision machined from graded aluminium alloy tooling plate, guaranteeing the fundamental characteristics specified at the design stage. These being: mechanical strength, corrosion resistance, and dimensional stability.

The KUTAVAR machine bed is applied with a powder coated surface, ensuring a durable and long-lasting coating, allowing it to perform in the most severe of environments. The machine gantry is surface anodised, allowing a high adhesion with the aluminium alloy without compromise to the dimensional tolerance of components.



Performance at its core

Quality, repeatability, and precision are at the heart of every KUTAVAR machine.

When working to the Thermal cutting industry standard, ISO 9013:2017, alignment, stability and accuracy are critical to the machine's performance when consistent clean cut surface quality is expected.

The dimensions of a cut piece are expected to reflect those of the drawing. We test and measure cross sectional areas up to 4,000 mm, where results are within 100µm. Dimensional tolerances in each part work together to create repeatable performance in every machine.

Our precision engineered planetary gearboxes are positioned in a way that allows smooth movement, which is reflected in the quality of parts produced on KUTAVAR machines.

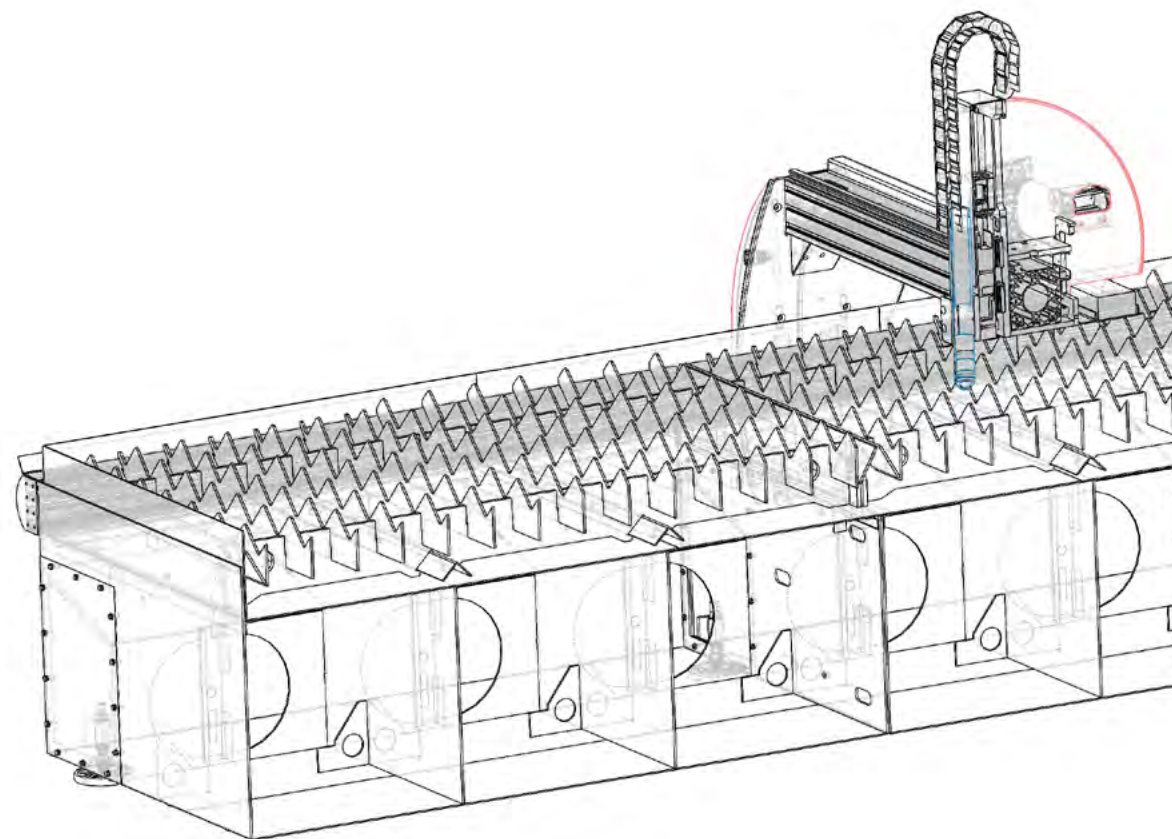



Assembly

Supplier quality assurance of outsourced manufactured components go through rigorous visual and dimensional inspection prior to being allocated as assembly stock.

Production staff are trained in line with standard instructions accompanied by visual aids. Using the poka-yoke process for assembly eliminates operational assembly mistakes and ensures right-first-time metrics for production build are 100%.

Every KUTAVAR machine undergoes precision testing using the Renishaw® ballbar. This allows us to calculate the machine's volumetric error, which ensures repeatable accuracy on all CNC plasma machines that are dispatched from our factory.



Our Machines

Our three-axis cutting machines consist of two distinct models: the **KUTAVAR MAX**, for air plasma and oxy-fuel cutting, or the **KUTAVAR MAX ULTRA**, for high-definition plasma.

We offer two extraction options: Waterbed or Zoned Extraction.

The machine's motion control and software incorporate CAD, CAM, CNC, with a pre-loaded library of standard flexi-shapes and profile nesting capabilities. Motor options available include NEMA 34 hybrid stepper or servo motors. Imports of DXF/DWG, G-code files, and image imports are also a standard feature. Customers will find the KUTAVAR software simple and intuitive to use, realising its powerful and seemingly endless capabilities.

KUTAVAR has the capability of incorporating *oxy-fuel gas cutting in addition to plasma, allowing cut thicknesses of up to 100 mm of mild steel. This is made possible by the heavy-duty build design, with permissible payloads of up to 5,000 Kg.

* (Zoned Extraction machines only).

A machine that is robustly engineered and built, capable of consistently performing in the most challenging of working environments, whilst producing guaranteed positional accuracy.

KUTAVAR machine sizes and weights can be found on page 11. In the event that a customer wishes to specify a machine outside of the standard sizes produced, please speak with us as we may be able to offer a bespoke solution.



Motors and Gearboxes

Configurable with NEMA 34 high torque stepper motors or, NEMA 34 servo motors with encoder, combined with high precision planetary gearboxes.



Integrated Software

Our software incorporates CAD, CAM, and CNC, with a pre-loaded library of standard flexi-shapes and profile nesting capabilities.



Weight Capacity

Design of build constructed for heavy-duty use, with a permissible weight load capacity of up to 5,000 Kg.



Manufacturer's Warranty

A comprehensive 5-year manufacturer's warranty.



MAX

For use with Oxy-Fuel,
Hypertherm Powermax and
MAXPRO200 Power Sources

- Precision Machined Components, Machined from Aluminium Tooling Plate
- Linear Rack and Pinion System
- NEMA 34 Hybrid Stepper Motors
- Available as Waterbed or Zoned Extraction

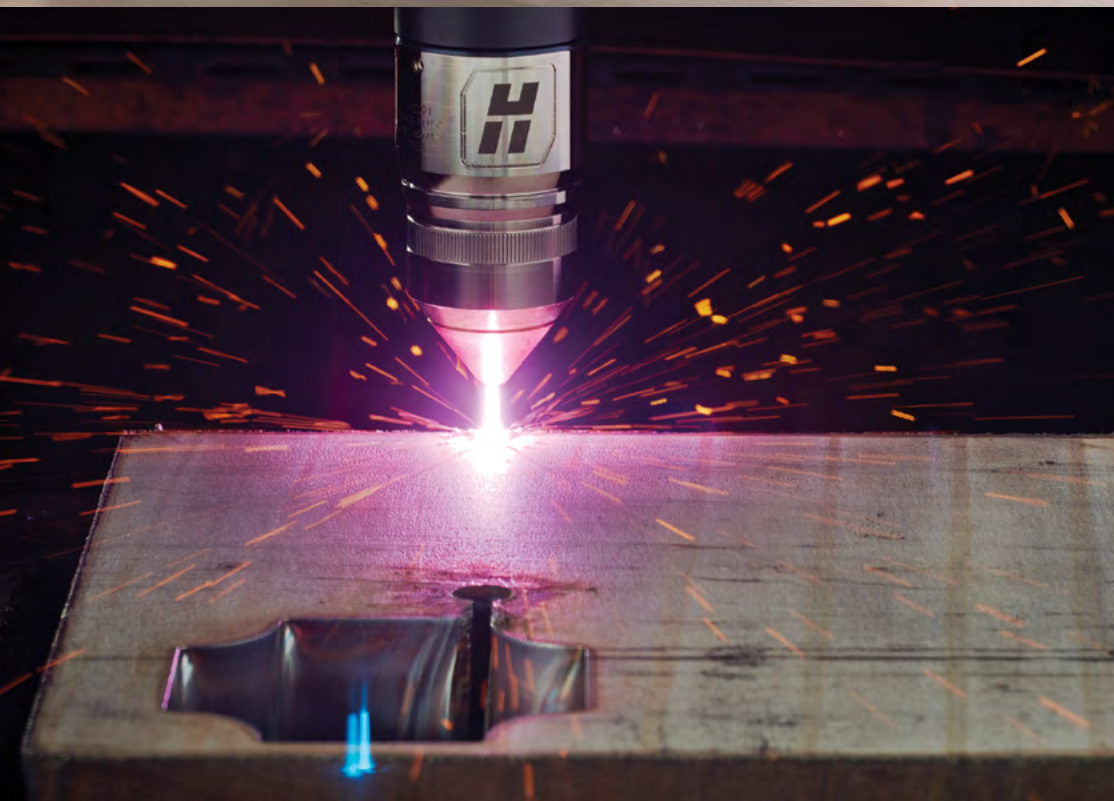

MAX ULTRA

For use with the High Definition
Hypertherm XPR Power Sources

- Precision Machined Components, Machined from Aluminium Tooling Plate
- Helical Rack and Pinion System
- NEMA 34 Servo Motors
- Available as Zoned Extraction
- Automatic Plasma Gas Control Console



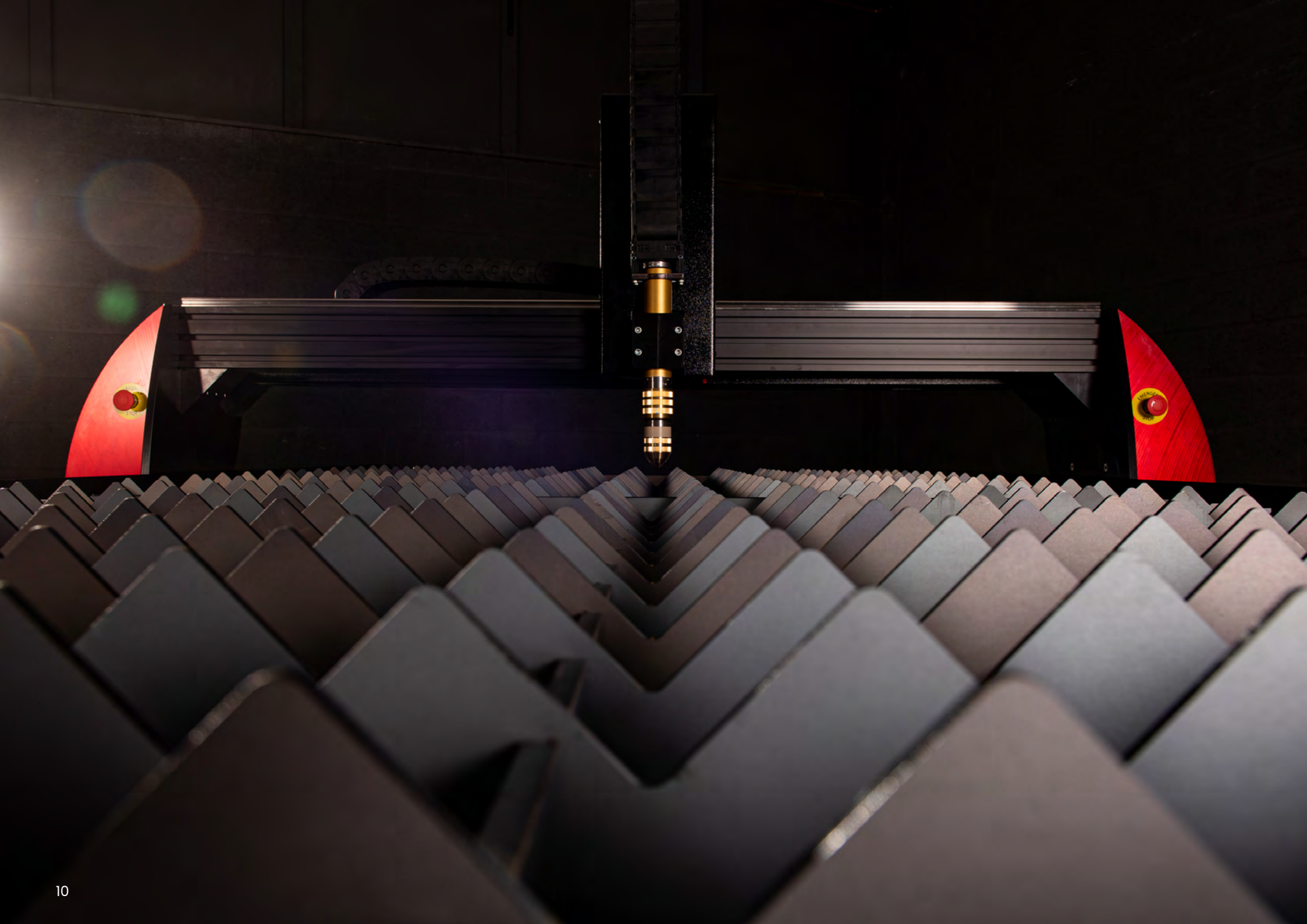

KUTAVAR Dimensions & Weights

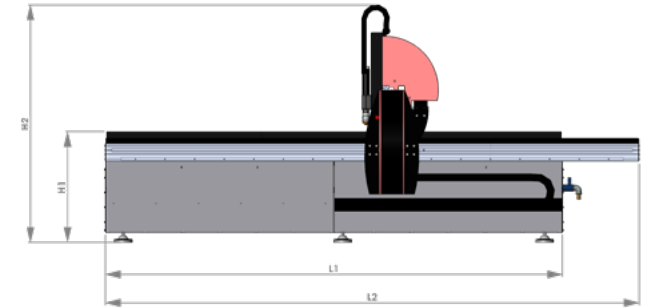
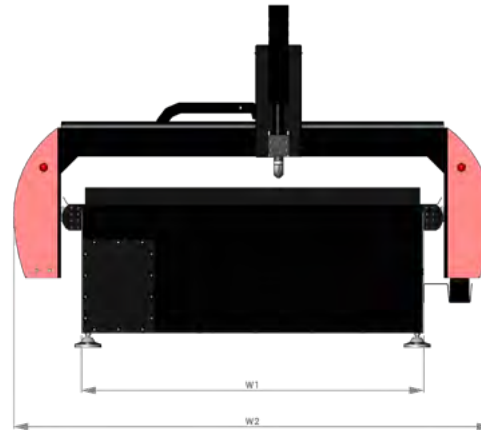
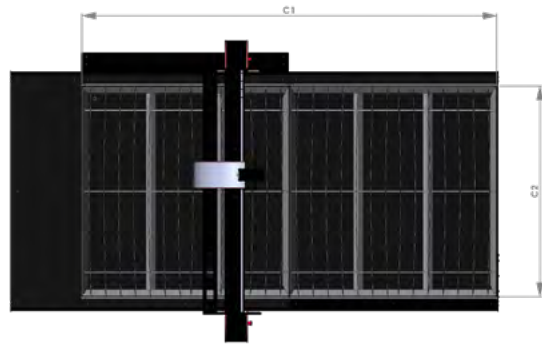

Reference	1250 x 1250	2500 x 1250	3000 x 1500	4000 x 2000
W1	1350	1350	1600	2100
W2	1980	1980	2230	2730
L1	1545	2575	3090	4120
L2	2065	3095	3610	4640
H1	750	750	750	750
H2	1600	1600	1600	1600
C1	1250	2500	3000	4000
C2	1250	1250	1500	2000

**All dimensions are in mm*

Approx. Weight	700 kg	1100 kg	1400 kg	2300 kg
-----------------------	--------	---------	---------	---------



Our Software

Simple yet powerful

If you have little to no CAD experience, KUTAVAR software makes it simple for you. In its 2D CAD suite you can quickly create your own shape, import DXF or DWG files, images, or choose from the library of pre-drawn shapes.

From design to cutting

From modifying drawings, nesting of multiple parts, and creating bolt-ready holes. KUTAVAR makes it a seamless process from design to manufacture.

Fully integrated solution

With integrated plasma and oxyfuel charts including Hypertherm, Kjellberg and other popular brands, it takes the guesswork out of important cutting parameters like feedrate, kerf, cut height and arc voltage.

Advanced controls

Advanced controls make cutting easier and more efficient. The true shape nesting feature can duplicate and automatically best place parts to maximise sheet yield, allowing you to increase your profitability.

Cost calculation

Easily calculate the price of each part in the nesting feature by inputting your material KG price.





CAD Features

- ✓ Shape Library
- ✓ Fix Drawing Tool
- ✓ Bridge Entities Tool
- ✓ Shape Welding Tool
- ✓ Measuring Tool
- ✓ Part Shading
- ✓ Free Form Stretching
- ✓ Free Form Manipulation
- ✓ Layer Support
- ✓ Centreline Image Support
- ✓ Silhouette Image Support
- ✓ Multi-Layer Colour Image Import
- ✓ DXF/DWG Import
- ✓ Arc Fitting



CAM Features

- ✓ TrueShape Nesting
- ✓ Automatic Kerf Compensation
- ✓ Import of parts from external files
- ✓ Grid Nesting
- ✓ Corner Looping
- ✓ Tabbng
- ✓ Overburn Support
- ✓ Advanced Leading Lead Out Editing
- ✓ Animated 3D Cutting Simulation
- ✓ Cut Sequencing
- ✓ Operation Sequencing
- ✓ Cutout or Part Mode
- ✓ Advanced Small Hole Processing
- ✓ Customisable Post Processor
- ✓ Multiple Tabs
- ✓ Drag, Delete, Rotate, Copy Parts on the Nest
- ✓ Multi-sheet and Fill Sheet True Shape Nesting
- ✓ Graphical Editing of Leading Lead Out Location
- ✓ Custom Views of Kerf Width, Cut Direction, Toolpath, Rapids and Part Geometry

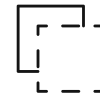

CNC Features

- ✓ Automatic Lead-In on Restart
- ✓ Dynamic THC on/off
- ✓ Jump to Line
- ✓ Dry Run
- ✓ Momentary Run
- ✓ Run File Forward and Backwards
- ✓ Kerf Crossing Detection
- ✓ Progress Meter
- ✓ Move to Point in Viewport
- ✓ Rip Cutting
- ✓ THC Performance History Chart
- ✓ Smart Touch Off



Application Features

- ✓ Plasma
- ✓ Oxyfuel
- ✓ Marker and Plasma Marking
- ✓ DXF Export
- ✓ Part Shading
- ✓ Commonly Used Plate List
- ✓ 3D Cutting Simulation
- ✓ Customisable Cut Charts
- ✓ Customisable Default Lead In, Lead Out Strategies
- ✓ Material Database (Cut Chart Support)
- ✓ Printing Support for Part Number Labels, Nest Report and Nest
- ✓ Advanced Text including True Type Font Support Without Exploding and Curved Text Around any Shape



In Partnership with Hypertherm



KUTAVAR CNC plasma cutting machines are powered by the leading global brand in plasma cutting, Hypertherm. We are uniquely positioned as one of the UK's only manufacturers of Compact CNC Cutting Machines with direct access to the full range of Hypertherm's Thermal Cutting Products. From the Powermax family, up to the advanced plasma cutting technology, the XPR Range. Depending on which power source is selected, a maximum pierce capacity of 50 mm is achievable.

Powermax Family



Dramatically simplifying the consumable changeover process, new SYNC cartridges can be changed in approximately 10 seconds.

Capable of piercing between 12 mm (Powermax45 SYNC) & 22 mm (Powermax105 SYNC) on mild steel. The SYNC series is a popular choice for most SMEs.

POWERSOURCE	Powermax45 SYNC	Powermax65 SYNC	Powermax85 SYNC	Powermax105 SYNC	Powermax125
Pierce Capacity (MS)	12 mm	16 mm	20 mm	22 mm	25 mm
Pierce Capacity (SS)	12 mm	12 mm	16 mm	20 mm	25 mm
Pierce Capacity (ALU)	10 mm	12 mm	16 mm	20 mm	25 mm

MAXPRO200

Hypertherm MAXPRO200 offers the fastest cutting speeds in its class, with a 32 mm pierce and 100% duty cycle at 200 A.

Engineered for heavy-duty, high-capacity mechanised cutting, the MAXPRO200 delivers repeatable performance across a range of industrial applications.

Bridging the gap between air plasma and high-definition, MAXPRO200 includes the option of cutting with pure oxygen plasma gas. Providing a cleaner edge and faster cutting compared to air plasma.



XPR Range

High-Definition (Hi-Def) plasma offers superior cut quality, tighter tolerances, and increased cutting speed when compared to conventional plasma.

Benefits include smoother cuts with minimal dross, narrower kerf width for reduced material waste, greatly improved accuracy for holes and intricate shapes, and enhanced edge squareness. Hi-Def plasma excels in cutting thicker metals while minimising the Heat-Affected Zone (HAZ), which is particularly valuable when cutting high volumes of stainless steel and aluminium.



POWERSOURCE	MAXPRO200	XPR170	XPR300	XPR460
Pierce Capacity (MS)	32 mm	40 mm	50 mm	64 mm
Pierce Capacity (SS)	25 mm	22 mm	38 mm	64 mm
Pierce Capacity (ALU)	32 mm	25 mm	38 mm	50 mm



Engraving Device

The engraving device allows operators to scribe part numbers, identification tags, logos, and illustrations into your sheet material. There are several other uses for the device such as:

- Fold lines for bending
- Precision hole drilling
- Weld positions

The KUTAVAR engraver significantly enhances the flexibility and efficiency of working with sheet materials, streamlining the process of marking and preparing materials while guaranteeing precision and consistency in the final product. The pneumatically powered engraver retracts when not in use, protecting it from the environment.





Slat Options

We offer two distinct types of slats, standard and HVAC.

Our standard triangular slats offer a durable and stable surface for most materials cut with a CNC plasma machine. We opted for a triangular design over the flatter slats commonly found in entry-level machines for ease of maintenance and to reduce the risk of fusing the material to the slat.

HVAC slats are designed for when increased contact is necessary between thin sheet material and the table itself. By limiting the degree of sheet material deflection, following heat distortion generated from the plasma power source, this provides greater stability for the material, maximising cut quality and yield.

KUTAVAR provides free DXF file drawings of both slat types to all of our customers. Allowing them to easily replace worn slats when required.

Oxy-fuel Cutting Head

Operated from the KUTAVAR Control Unit - control gas flow, ignition, pre-heat and cut, in complete safety

Available with all KUTAVAR MAX, zoned-extraction tables is the option of cutting with Oxy-fuel. With a simple manual changeover, this allows the operator to swap from the plasma torch to the gas torch in seconds.

The Oxy-fuel cutting head is paired with our raised gantry, allowing for cutting of a fully sized metal sheet up to 100mm thick.

Oxy-fuel provides a cost-effective and highly accurate straight-edge cut on a variety of materials, although due to its slower travel speed when compared to plasma, it is typically used on materials in excess of 30mm.

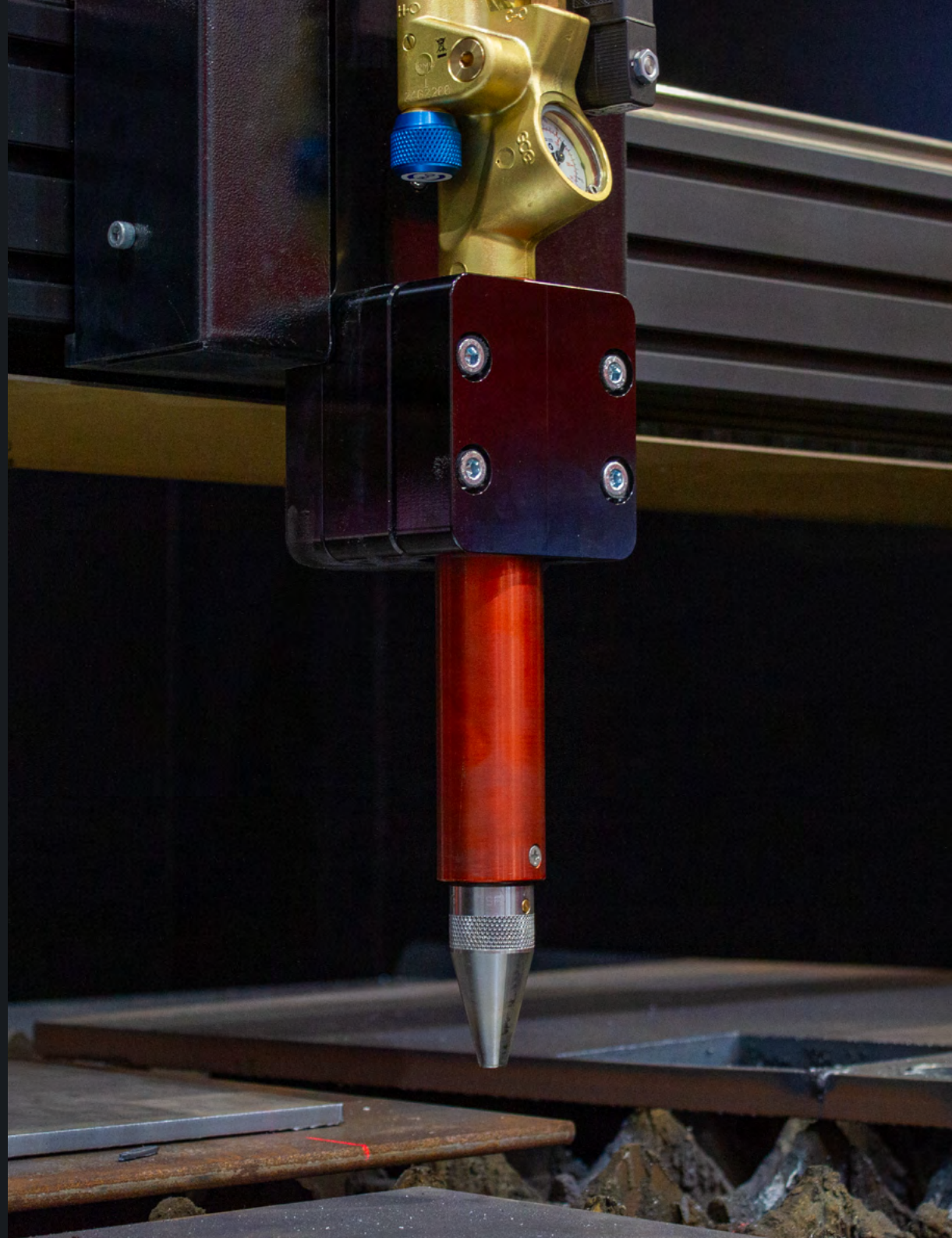

KEMPER®

Fume Extraction

KEMPER PlasmaFil - specifically suited for plasma or flame cutting processes

A central extraction and filtration system, designed to capture both smoke and dust particles, and recirculate clean air. The unit is standalone and is especially suited when ductwork through an exterior wall is not practical.

The unit comes installed with KemTex® ePTFE membrane filter cartridges, designed to capture and separate ultra-fine dust particles below 0.1 μm (0.1 microns).



Training

The KUTAVAR training programme is aimed at delivering the essential knowledge to Operators, so that they can become competent in the use of their machine.

Depending on the KUTAVAR package purchased, you will receive a minimum 2 days of installation and training on your new KUTAVAR Machine at your site, making it personal and very intuitive.

Our experienced engineers will simply demonstrate the capabilities of your new machine, ensuring optimised cutting performance. This can be tailored in several ways to suit your individual needs;

- Customer on-site training (as standard)
- KUTAVAR in-house training facilities
- Partnering agent facilities
- Remotely via online platforms.

Additional training can be easily accessible by contacting our technical aftercare support team or, by visiting the helpful support resources which can be found on our website.





Warranty & Aftercare

Each KUTAVAR machine comes with a comprehensive five-year manufacturer's warranty.

To ensure this level of protection and performance, the warranty is only valid subject to signing our Annual Service Agreement. This agreement guarantees your machine receives the expert care, maintenance, and support it needs to stay operating at peak performance.

We are committed to offering a total aftercare service through our highly experienced and knowledgeable support team, with the ability to offer a quick and dependable service to assist with queries and general maintenance.

Our Service Team are here to help, giving you access to technical expertise and common-sense advice.



What Our Customers Say

“Any issues we have, they’re there to sort it for us.”

Stevend Engineering - Film Industry

Machine Specification: KUTAVAR MAX,
3 x 1.5 m Waterbed, Hypertherm Powermax105, Engraver

What Our Customers Say

“The plasma is doing three processes in one, and has increased production.”

Powell & Co. Construction - Steel Frame Building

Machine Specification: KUTAVAR MAX, 3 x 1,5 m Zoned Extraction, Hypertherm MAXPRO200, BOGE Compressor, KEMPER Extraction System





KUTAVAR

Redefining the design and manufacture of CNC plasma cutting machines

1 Beacon Road,
Hereford, Herefordshire
HR2 6JF
United Kingdom

Phone: +44 (0)1432 805700

Email: sales@kutavar.com

Website: www.kutavar.com



British

© KUTAVAR UK | 2026 - V4

