

HEAVY LINE
Crushers | Screeners | Trommels | Conveyors



SCREENPOD.CO.UK



DESIGN & MANUFACTURE OF
INNOVATE PRODUCTS AND
SOLUTIONS FOR THE WORLDS
RECYCLING & AGGREGATE SECTORS

Revo 1200T Crushing 6mm grit to make 0-2.5mm agg-lime product.

ABOUT SCREENPOD DESIGN & MANUFACTURING

Established in 2013, Screenpod Design & Manufacturing produce a comprehensive portfolio of unique & innovative products renowned for their outstanding performance and durability at our headquarters in Dungannon, Co. Tyrone.

From humble beginnings, we have rapidly gained an acclaimed name for our exceptional range of machines and continue to build upon this foundation by striving forward with relentless research and development to further forge our reputation for creating world class products.

Our core value is to construct machines that are built to last, and this ethos drives us to not only exceed our customer's expectations but to create machines that can be relied upon to perform at the highest-level day after day for years to come.

Screenpod electrical and control systems are built and supported inhouse, for rapid and effective world class product support and quality control.



6-9	Scalpers
10-11	Trommels
12-15	Tracked Conveyors
16-19	Tracked Finishing Screens
20-23	Reversible Tertiary Impactor
24-25	Primary/Secondary Impactors
26-27	Jaw Crusher
28-29	Cone Crushers

HEAVY LINE - ENVIRONMENTAL SCALPERS

The range of heavy duty screens offer optimum screening and stockpiling of materials. Designed with the contractor in mind the scalpels offer high productivity whilst also allowing flexibility within the easily portable tracked system.

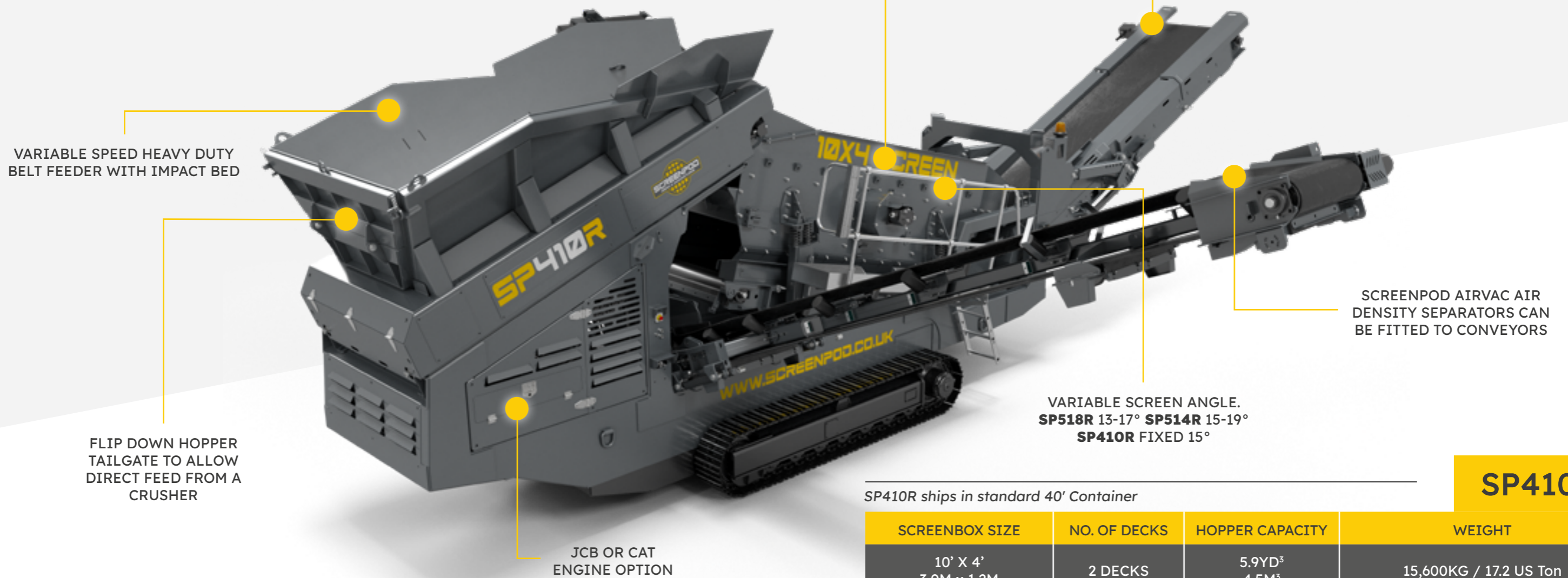

OPTIONS

APRON FEEDER (SP518R - SP514R)

RADIO REMOTE CONTROL

OVERBAND MAGNET

SCREEN DECKS - MESH, BOFAR BAR, FINGER SCREENS OR PUNCH PLATES

SP410R WILL FOLD AND SHIP WORLDWIDE IN STANDARD 40' SEA CONTAINER

SP514R LONGEST SCREENBOX IN COMPACT SCREENING SEGMENT

SP518R AVAILABLE IN BOTH APRON AND BELT FEEDER OPTIONS TO SUIT MULTIPLE APPLICATIONS

			SP410R
SCREENBOX SIZE	NO. OF DECKS	HOPPER CAPACITY	WEIGHT
10' X 4' 3.0M x 1.2M	2 DECKS	5.9YD ³ 4.5M ³	15,600KG / 17.2 US Ton

SP410R ships in standard 40' Container

			SP514R
SCREENBOX SIZE	NO. OF DECKS	HOPPER CAPACITY	WEIGHT
14' X 5' 4.27M x 1.5M	2 DECKS	9.4YD ³ 7.2M ³	Apron - 27,500KG / 30.1 US Ton Belt - 24,300KG / 26.7 US Ton

			SP518R
SCREENBOX SIZE	NO. OF DECKS	HOPPER CAPACITY	WEIGHT
18' X 5' 5.5M X 1.5M	2 DECKS	10.5YD ³ 8M ³	Apron - 32,000KG / 35.3 US Ton Belt - 30,500KG / 33.6 US Ton



HEAVY LINE - ENVIRONMENTAL SCALPER GRID

The Screenpod SPG100 Scalping Screen is engineered for heavy-duty screening of coarse material in tough working conditions. It removes fines and small debris early in the process, improving efficiency and protecting crushers and other downstream equipment. Ideal for use with aggregates, soil, rubble, and demolition waste, the SPG100 ensures only oversized material moves forward. Compact, robust, and reliable — it's built for productivity in quarries, recycling, and construction sites.

TIPPING FUNCTION
ACTIVATED
HYDRAULICALLY

ANGLE ADJUSTABLE
VIBRATING GRID

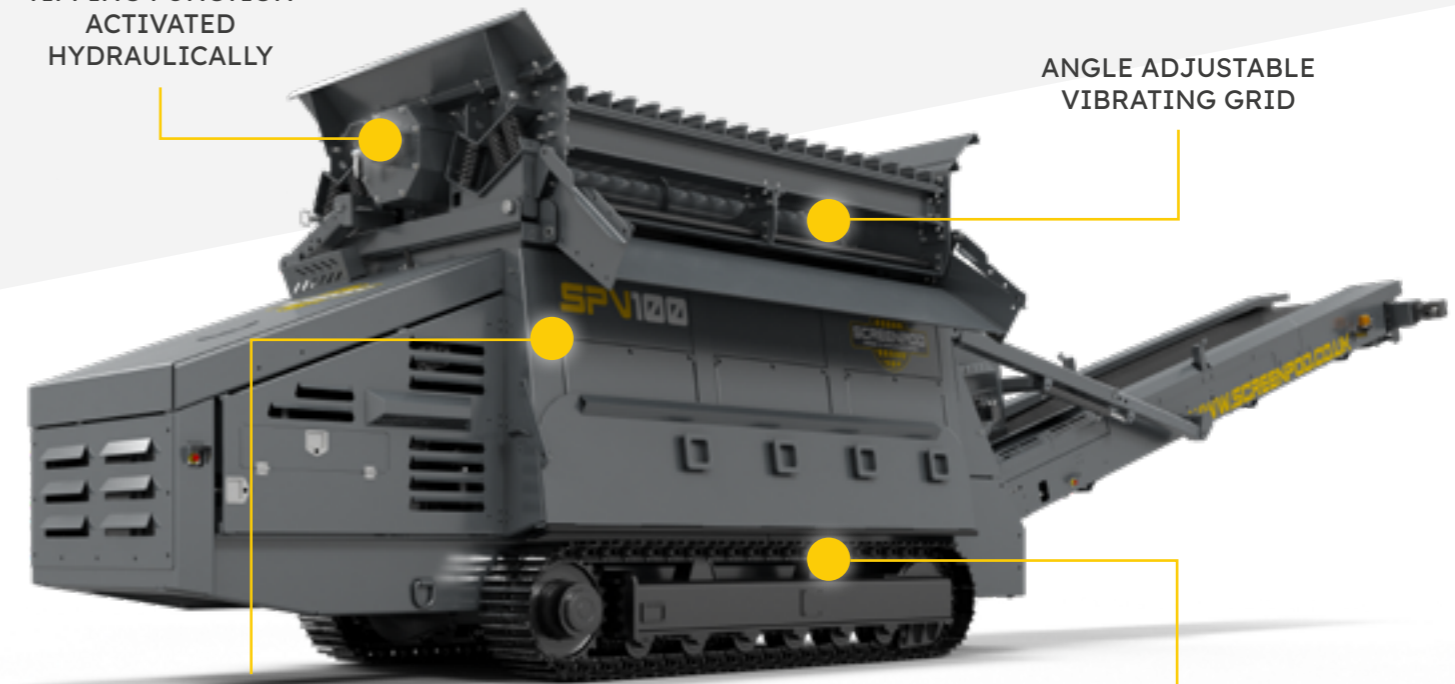

INDEPENDENTLY
CONTROLLED FEEDER
AND DISCHARGE BELTS

ROBUST CHASSIS & TRACK
FRAME ENSURES MAXIMUM
DURABILITY

OPTIONS

- VIBRATING GRIND WING EXTENSIONS
- OVERBAND MAGNET
- WEAR RESISTANT HOPPER LINERS
- RADIO REMOTE CONTROL
- DUST COVERS

SPG100 ships in standard 40' Container

SPG100

VIBRATING GRID	CAPACITY	HOPPER CAPACITY	WEIGHT
12' X 6' 3.7M X 2M	UP TO 600 TPH	6.3YD ³ 4.8M ³	18,900KG / 20.8 US Ton

HEAVY LINE - ENVIRONMENTAL TROMMELS

With organic waste comes a magnitude of problems but the Screenpod trommel range can handle any application. With a unique lift bar system within the drum material is lifted and thrown in order to break up material more easily. Suitable for many applications including compost, organic, wood chip and aggregate.

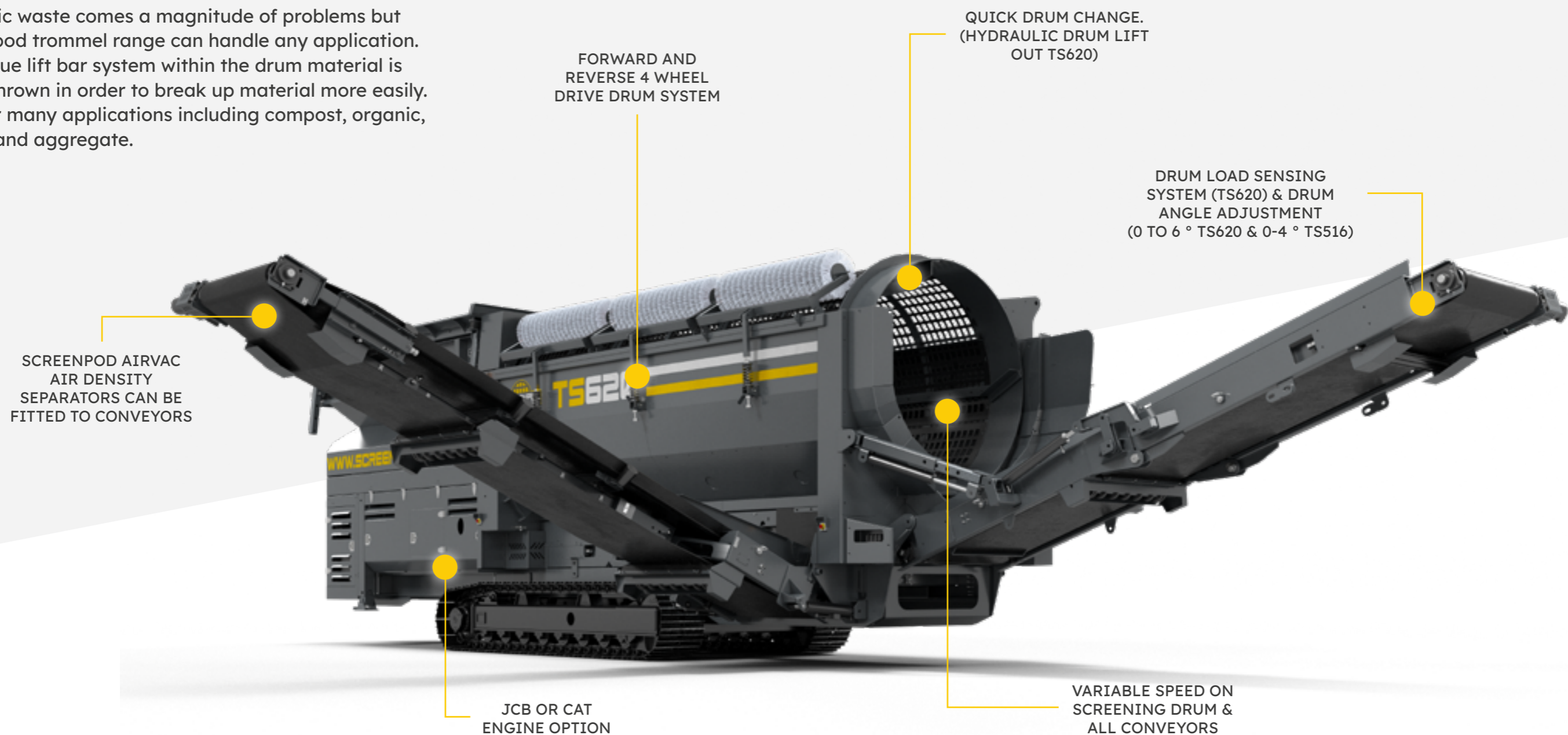

OPTIONS

- PUNCH PLATE MESH
- SCROLL SCREENING DRUM
- REMOTE TIPPING GRID
- RADIO REMOTE CONTROL
- HOPPER EXTENSIONS
- WHEEL CHASSIS
- TS620** SINGLE DECK VIBRATING GRID



TS620

VIBRATING GRID	DRUM SIZE	HOPPER CAPACITY	WEIGHT
12' X 6' 13.7M X 2M	18' X 6' 7" 5.5M X 2M	12.6YD ³ 9.6M ³	20,000KG / 22 US Ton

TS516

TS516 ships in standard 40' Container

CAPACITY	DRUM SIZE	HOPPER CAPACITY	WEIGHT
UP TO 150 TPH	16' 9" X 4' 5" 5.15M X 1.37M	5.2YD ³ 4M ³	14,500KG / 16 US Ton

HEAVY LINE - ENVIRONMENTAL TRACKED CONVEYORS

Screenpod have a comprehensive range of tracked conveyors designed to suit a wide variety of applications. From taking feed from a primary jaw crusher to recirculating material in a crushing train. By reducing double handling and your cost per ton these heavy duty mobile stockpilers will enhance your operation and bottom line.

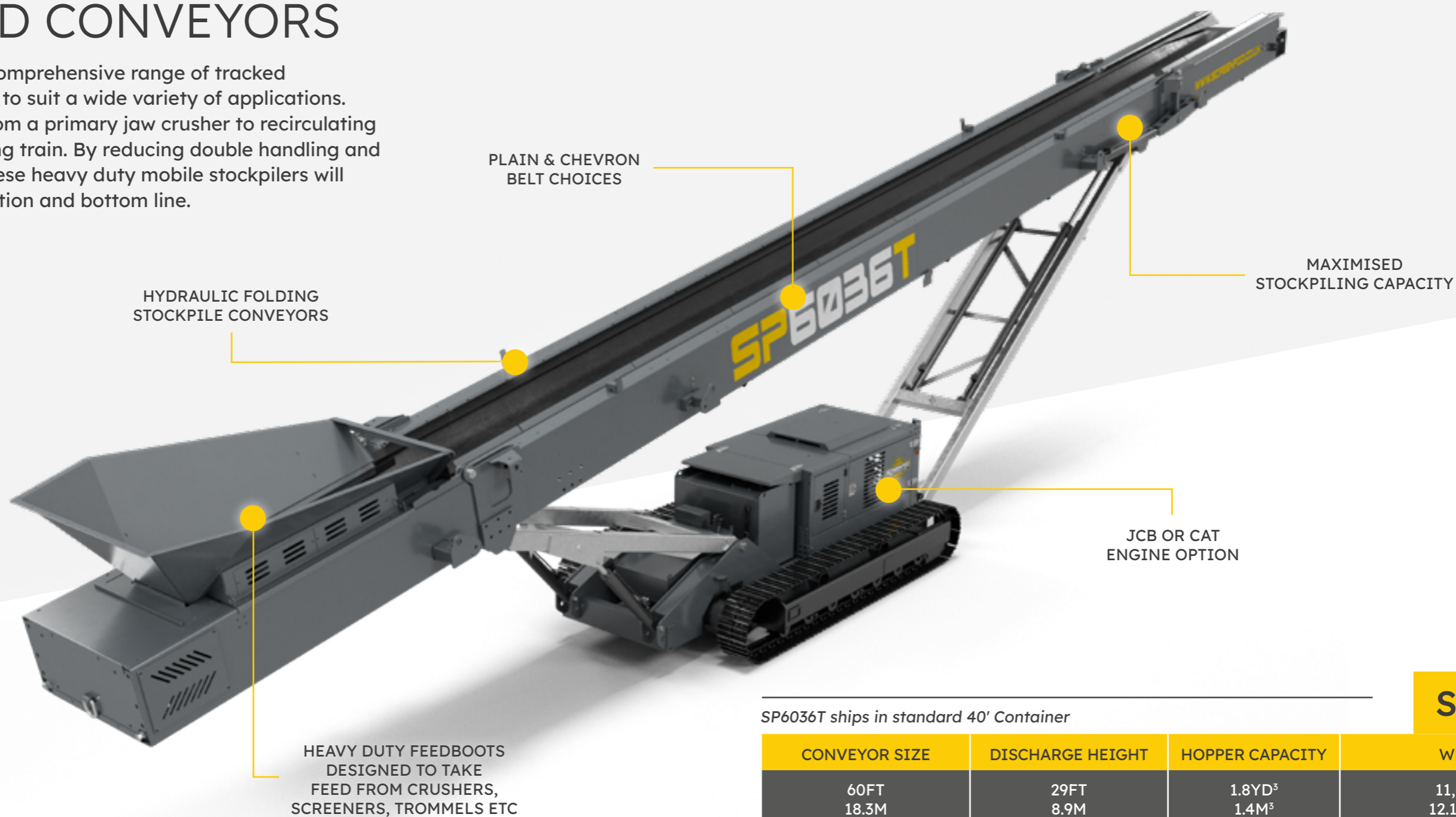

OPTIONS

- OVERBAND MAGNET
- CHEVRON BELT
- EXTENDED FEEDBOOTS
- ENCLOSED SKIRTING
- DUST COVERS



SP6036T ships in standard 40' Container

SP6036T

CONVEYOR SIZE	DISCHARGE HEIGHT	HOPPER CAPACITY	WEIGHT
60FT 18.3M	29FT 8.9M	1.8YD ³ 1.4M ³	11,000KG 12.1 US Ton

SP8042T ships in standard 40' Container

SP8042T

CONVEYOR SIZE	DISCHARGE HEIGHT	HOPPER CAPACITY	WEIGHT
75FT 23M	34.5FT 10.5M	2.1YD ³ 1.6M ³	14,500KG 16 US Ton

SP10042T

CONVEYOR SIZE	DISCHARGE HEIGHT	HOPPER CAPACITY	WEIGHT
101FT 31M	44FT 13.5M	2.1YD ³ 1.6M ³	19,200KG 21.16 US Ton

HEAVY LINE - ENVIRONMENTAL TRACKED BELT FEED CONVEYORS (FEEDER STACKERS)

Screenpod range of tracked belt feeder conveyors, (feeder stackers) are designed for heavy duty loading operations. With a separate large hopper for direct feeding with belt feeder, material can be regulated onto the main discharge belt. The direct feed hopper can be fitted with tipping grid, extensions or 2 deck vibrating grid.

SPF100

SPF100 ships in standard 40' Container

CONVEYOR SIZE	DISCHARGE HEIGHT	HOPPER CAPACITY	WEIGHT
32.8FT 10M	12.8FT 3.9M	13YD ³ 10M ³	Open Feed - 12,700KG / 14 US Ton w/ Tipping Grid - 14,400KG / 15.8 US Ton w/ Livehead - 17,200KG / 18.9 US Ton

SPF150

SPF150 ships in standard 40' Container

CONVEYOR SIZE	DISCHARGE HEIGHT	HOPPER CAPACITY	WEIGHT
49.2FT 15M	20.8FT 6.35M	13YD ³ 10M ³	Open Feed - 13,300KG / 14.7 US Ton w/ Tipping Grid - 15,000KG / 16.7 US Ton w/ Livehead - 17,800KG / 19.6 US Ton

SPF200

CONVEYOR SIZE	DISCHARGE HEIGHT	HOPPER CAPACITY	WEIGHT
65.5FT 20M	28.5FT 8.7M	13YD ³ 10M ³	Open Feed - 14,495KG / 15.9 US Ton w/ Tipping Grid - 17,000KG / 18.7 US Ton w/ Livehead - 18,985KG / 20.9 US Ton

HEAVY DUTY DESIGN & BUILD

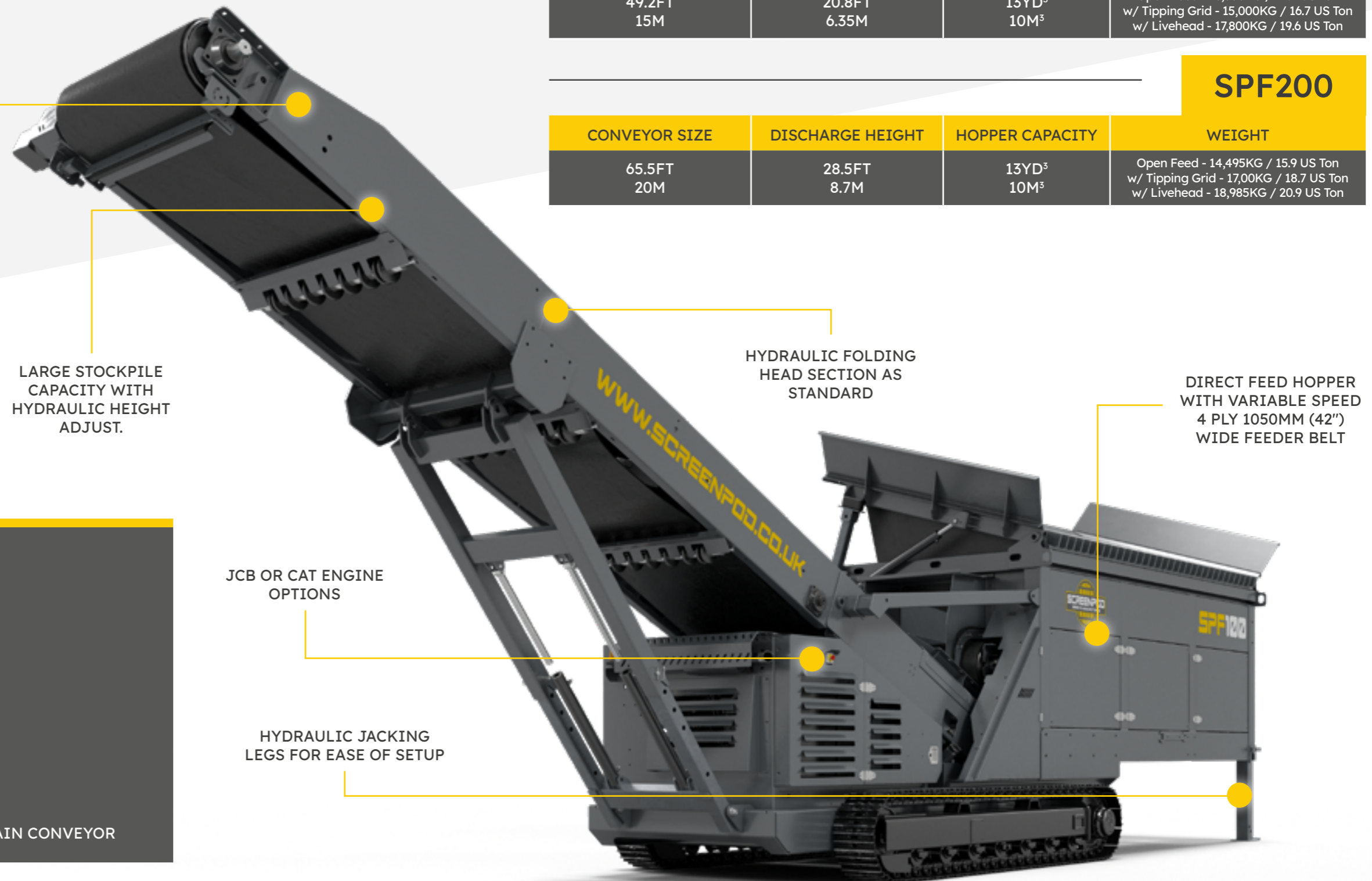

LARGE STOCKPILE CAPACITY WITH HYDRAULIC HEIGHT ADJUST.

HYDRAULIC FOLDING HEAD SECTION AS STANDARD

DIRECT FEED HOPPER WITH VARIABLE SPEED 4 PLY 1050MM (42") WIDE FEEDER BELT

JCB OR CAT ENGINE OPTIONS

HYDRAULIC JACKING LEGS FOR EASE OF SETUP

OPTIONS

- TWIN DECK VIBRATION GRID
- STRAIGHT EXTENSIONS
- MULCHING DRUM
- REMOTE CONTROL TIPPING GRID
- OVERBAND MAGNET
- ANTI-ROLL BACK ON MAIN CONVEYOR
- DUST COVERS
- RADIO REMOTE CONTROL
- OPTIONAL FLARED EXTENSION
- TWIN DRIVE MOTORS ON FEEDER AND / OR MAIN CONVEYOR

HEAVY LINE - AGGREGATE TRACKED FINISHING SCREENS – COMPACT UP TO 70FT² PER DECK

The Screenpod Large compact of tracked incline finishing screens, are based on a high energy aggressive screening action for maximum efficiency in screening performance with up to 70 ft² screening area per deck. Various models are available to suit output requirements and varying applications including rinser screen setup for wet washing of material.

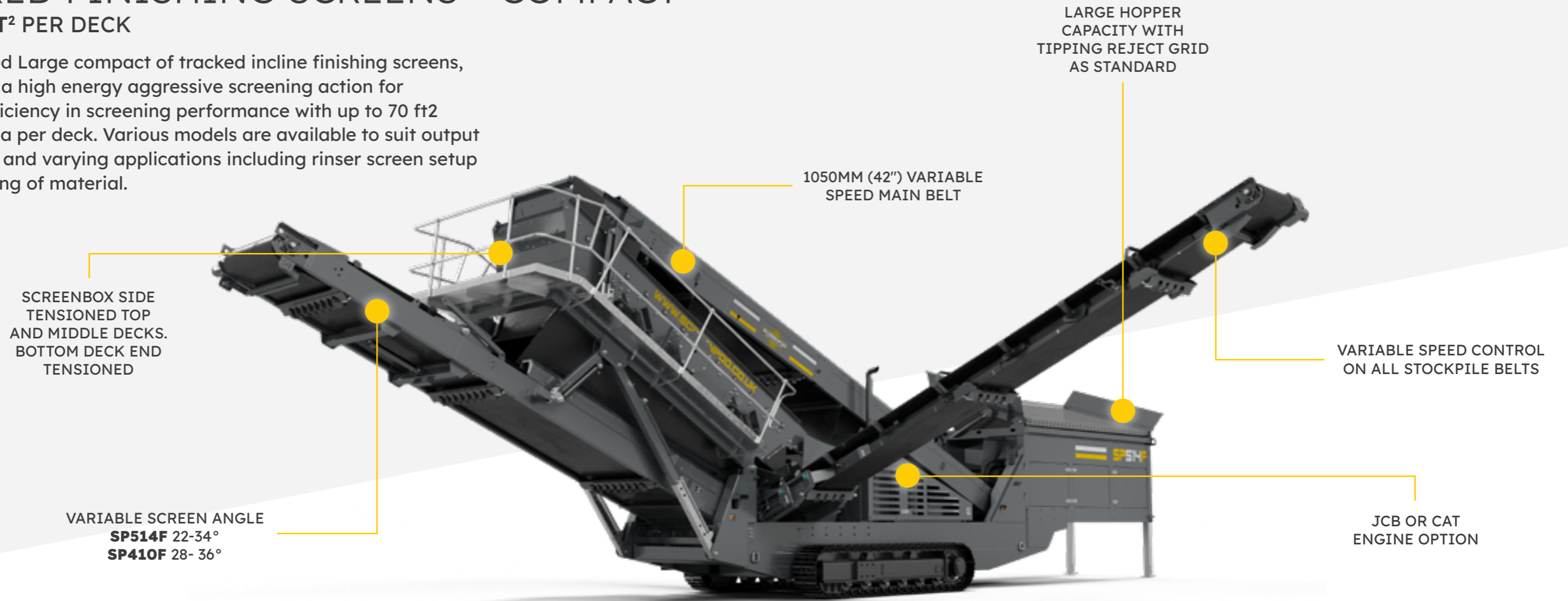

OPTIONS

- RINSER SCREEN, SPRAYBARS & CATCHBOX
- ANTI-ROLL BACK
- HOPPER EXTENSIONS
- VIBRATING GRID
- TIPPING GRID
- RADIO REMOTE CONTROL
- DUST COVERS
- OVERBAND MAGNET
- ANTI-ROLL BACK
- SCREEN DECKS – MESH, PIANO WIRE OR PUNCH PLATE



SP410F ships in standard 40' Container

SP410F

SCREENBOX SIZE	NO. OF DECKS	HOPPER CAPACITY	WEIGHT
10' X 4' 3M X 1.2M	2 DECKS	7.1YD ³ 5.8M ³	15,500KG / 17 US Ton

SP514F 2D

SCREENBOX SIZE	NO. OF DECKS	HOPPER CAPACITY	WEIGHT
14' X 5' 4.3M X 1.5M	2 DECKS	10.5YD ³ 8M ³	26,500KG / 29 US Ton w/ livehead 31,000KG / 34 US Ton

SP514F 3D

SCREENBOX SIZE	NO. OF DECKS	HOPPER CAPACITY	WEIGHT
14' X 5' 4.3M X 1.5M	3 DECKS	10.5YD ³ 8M ³	28,500KG / 31 US Ton w/ livehead 33,000KG / 36 US Ton

HEAVY LINE - AGGREGATE TRACKED FINISHING SCREENS – LARGE

UP TO 100FT² PER DECK

The Screenpod Large range of tracked incline finishing screens, are based on a high energy aggressive screening action for maximum efficiency in screening performance with up to 100 ft² screening area per deck. Various models are available to suit output requirements and varying applications including rinser screen setup for wet washing of material.



OPTIONS

- RINSER SCREEN, SPRAYBARS & CATCHBOX
- ANTI-ROLL BACK
- HOPPER EXTENSIONS
- VIBRATING GRID
- TIPPING GRID
- RADIO REMOTE CONTROL
- DUST COVERS
- OVERBAND MAGNET
- ANTI-ROLL BACK
- SCREEN DECKS – MESH, PIANO WIRE OR PUNCH PLATE



SP520F 2D

SCREENBOX SIZE	NO. OF DECKS	HOPPER CAPACITY	WEIGHT
20' X 5' 6.15M X 1.5M	2 DECKS	10.5YD ³ 8M ³	31,640KG / 34.8 US Ton w/ livehead 36,640KG / 40.3 US Ton

SP520F 3D

SCREENBOX SIZE	NO. OF DECKS	HOPPER CAPACITY	WEIGHT
20' X 5' 6.15M X 1.5M	3 DECKS	10.5YD ³ 8M ³	38,720KG / 42.7 US Ton w/ livehead 43,220KG / 49.8 US Ton

HEAVY LINE - AGGREGATE TRACKED MOBILE CRUSHERS

Screenpod have a comprehensive range of mobile crushers from primary jaw crushers to the revolutionary Revo 1200T reversible tertiary impactor.

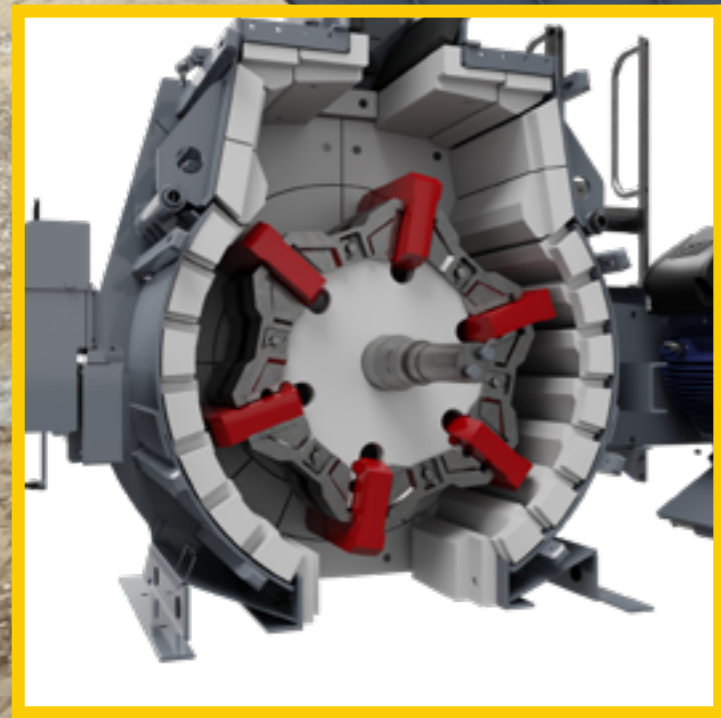

Revo 1200T Crushing 20mm river gravel producing 0-6mm manufactured sand.

REVO

HEAVY LINE - AGGREGATE TRACKED REVERSIBLE TERTIARY IMPACTOR

The REVO 1200T is a revolutionary design in terms of high reduction crushing. Fitted with a reversible impact chamber, with 6 hammer, 1200mm diameter rotor and a unique adjustment system to maintain constant CSS gap setting from the top to the bottom of the chamber to maintain a consistent reduction ratio unlike no other crusher. All in a tracked mobile system with instant variable speed control on the rotor tip speed to tailor output to each and every application at the touch of a button.

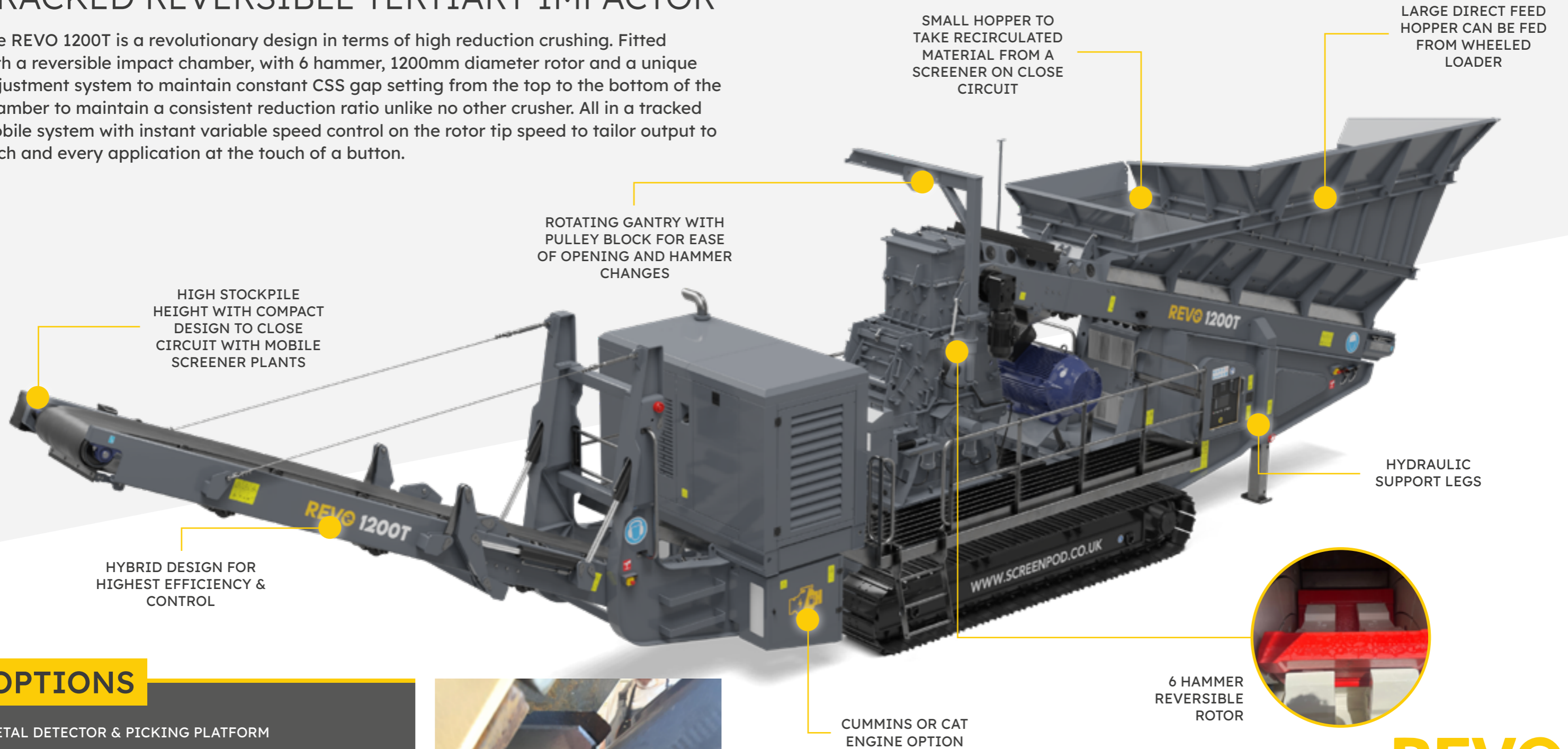

OPTIONS

- METAL DETECTOR & PICKING PLATFORM
- OVERBAND MAGNET - TWIN POLE
- TIPPING GRID WITH REMOTE CONTROL - NO SHROUD SCALES
- AUTOLUBE
- EMERGENCY PULL WIRES (2 CONVEYORS)
- DISCHARGE CONVEYOR HEAD CHUTE & RUBBER SOCK
- WORKING LIGHTS
- DUST SUPP UP-GRADE 3 X BARS & MANIFOLD
- 24V WATER PUMP & FILTER UPGRADE
- AVAILABLE IN STATIC & MODULAR FORMAT



REVO 1200T

MAX FEED SIZE	TONNAGE	HOPPER SIZE	FEED OPENING	WEIGHT
150MM	150 TPH	7.2 YD ³ 5M ³	610mm x 240mm 23" x 9.5"	28,500KGS / 62,831 LBS
ROTOR	ROTOR SPEED	ROTOR DIAMETER	PASSING Ø 6MM:	ADJUSTMENT CRUSHING GAP RANGE
6 IMPACT BARS (9 IMPACT AREAS)	450-900 RPM ADJUSTABLE ON VSD	1200MM	60-80% SINGLE PASS	150MM / 150MM IN BOTH DIRECTIONS

HEAVY LINE - AGGREGATE TRACKED PRIMARY/SECONDARY IMPACTORS

Screenpod's range of mobile impact crushers are designed to suit both primary and secondary applications, either as standalone units or integrated into a crushing circuit. The Screenpod impactor range is designed to produce high quality cubical product at a low cost per ton. Suitable for limestone, basalt, recycling & demolition, concrete, asphalt and more.

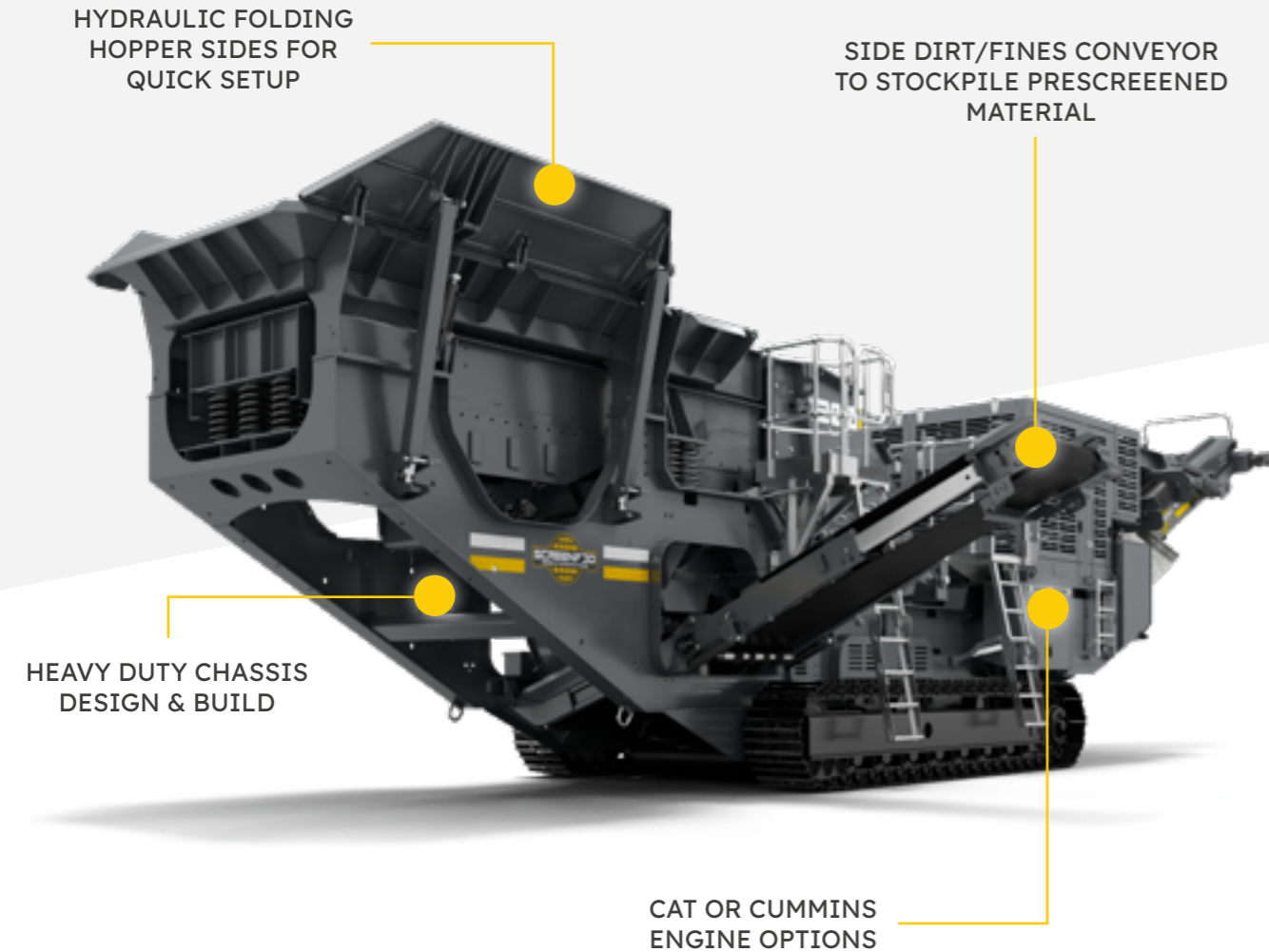

				1200I
MAX FEED SIZE	TONNAGE	HOPPER SIZE	FEED OPENING	WEIGHT
1000MM 39"	UP TO 450 TPH	8.5YDS 6.5M ³	1090 X 1040MM 43"X45"	40,000KGS / 88,185 LBS

				1200IR
MAX FEED SIZE	TONNAGE	HOPPER SIZE	FEED OPENING	WEIGHT
1000MM 39"	UP TO 450 TPH	8.5YDS 6.5M ³	1090 X 1040MM 43"X45"	50,000KGS / 110,231 LBS
				SCREENBOX
				12'X5' / 3.66M X 1.52M 2 DECK

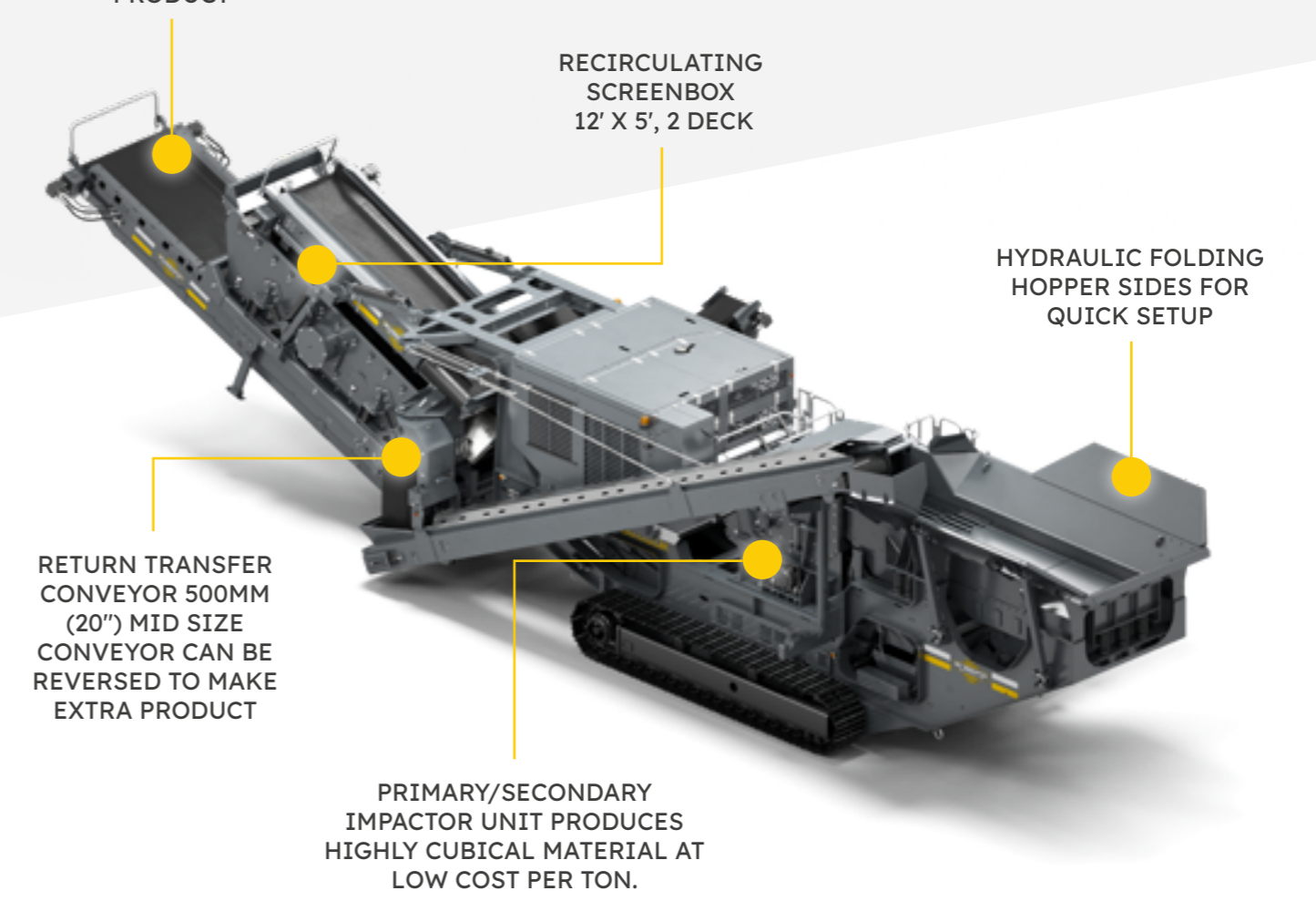

OPTIONS

- RECIRCULATION PACKAGE
- RECIRCULATION SCREEN DECKS - MESH OR PIANO WIRE
- DUST COVERS ON MAIN AND DISCHARGE CONVEYORS
- VARIOUS FEEDER UNDERSCREEN MESH
- BELT SCALE
- LIGHT MAST AND CABINET LIGHTS
- STEEL PAN FEEDER UNDER CHAMBER



HEAVY LINE - AGGREGATE TRACKED JAW CRUSHER

Screenpod's jaw crushing range of mobile crushers are designed to suit applications where the toughest demands of primary crushing are of imperative importance. Screenpod's jaw crushing range are aggressive and powerful crushers that bring together the proven ability of the universal jaw chamber within an innovative Screenpod tracked solution.

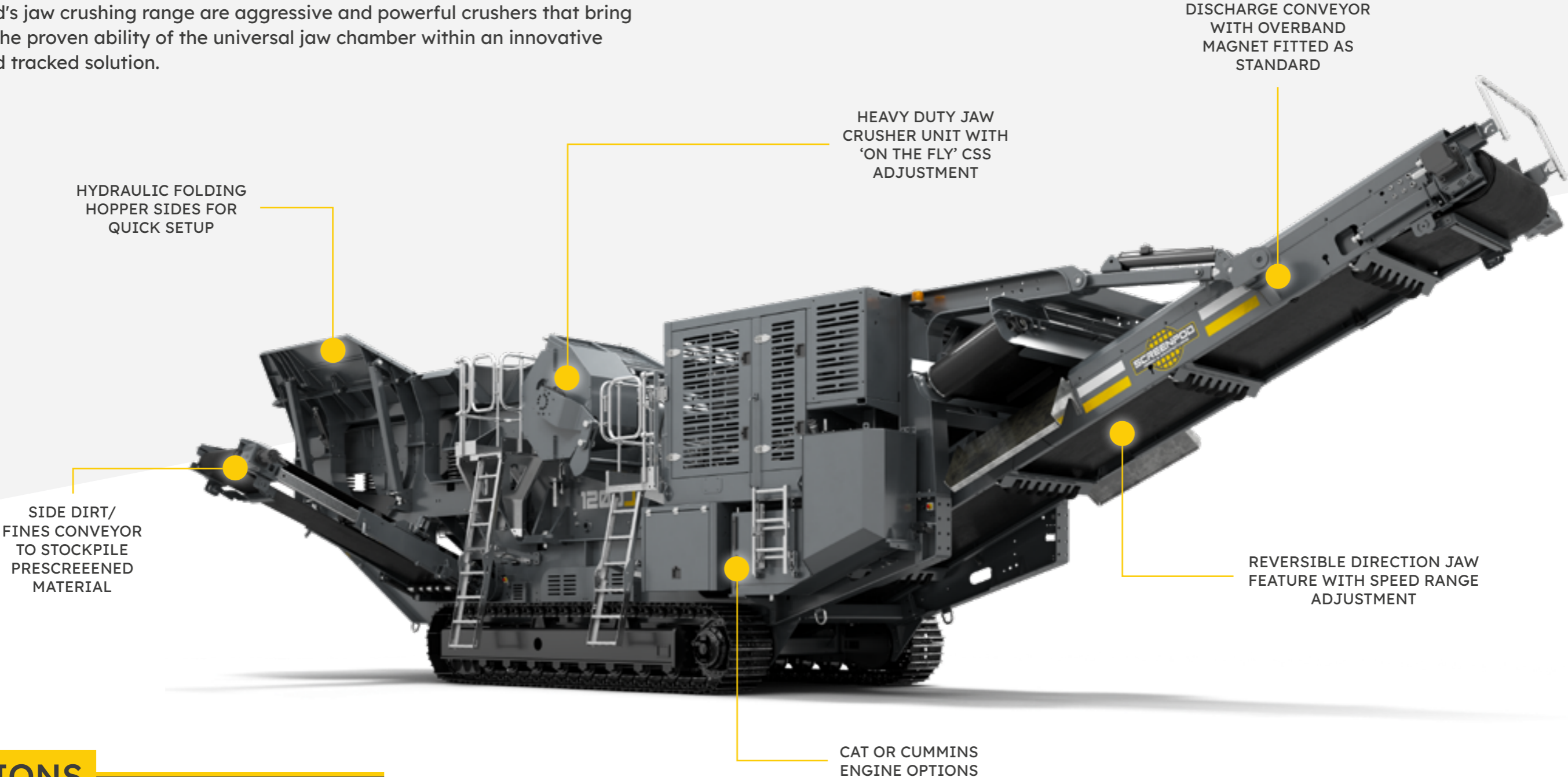

OPTIONS

- DUST COVERS ON MAIN AND DISCHARGE CONVEYOR
- SUPER/MULTI TOOTH JAW DIES
- VARIOUS FEEDER UNDERSCREEN MESH
- BELT SCALE
- DEFLECTOR PLATE UNDER JAW
- LIGHT MAST AND CABINET LIGHTS
- WATER PUMP & FILTER UPGRADE



				1200J
MAX FEED SIZE	TONNAGE	HOPPER SIZE	FEED OPENING	WEIGHT
700MM 28"	UP TO 350 TPH	8.5YDS 6.5M ³	1100 X 700MM 28"X44"	45,350KGS / 99,980 LBS

HEAVY LINE - AGGREGATE TRACKED CONE CRUSHERS

The Screenpod cone crusher range are designed for secondary crushing in hard and abrasive materials, at the lowest cost per ton. These robust secondary crushers are fitted with the proven FLSmidth Raptor Cone Crusher chamber, and can come with open circuit and after screen options. Fitted with large wing hopper the 1200C models can be shovel fed, or integrated into an existing crushing and screening plant. A choice of liners and heads are available to suit differing applications.

1200CR

MAX FEED SIZE	TONNAGE	HOPPER SIZE	FEED OPENING	WEIGHT
235MM 9.25"	UP TO 250 TPH	8.24YDS 6.3M ³	953mm 37.5"	40,000KGS / 88,184 LBS
				SCREENBOX
				12'X5' / 3.66M X 1.52M 2 DECK

ULTRASONIC LEVEL SENSOR SYSTEM FITTED TO OPTIMISE FEED TO CRUSHER UNIT

ROBUST FEED HOPPER WITH HYDRAULIC WINGS, BELT PROTECTION ROCK SHELF, AND METAL DETECTION FITTED

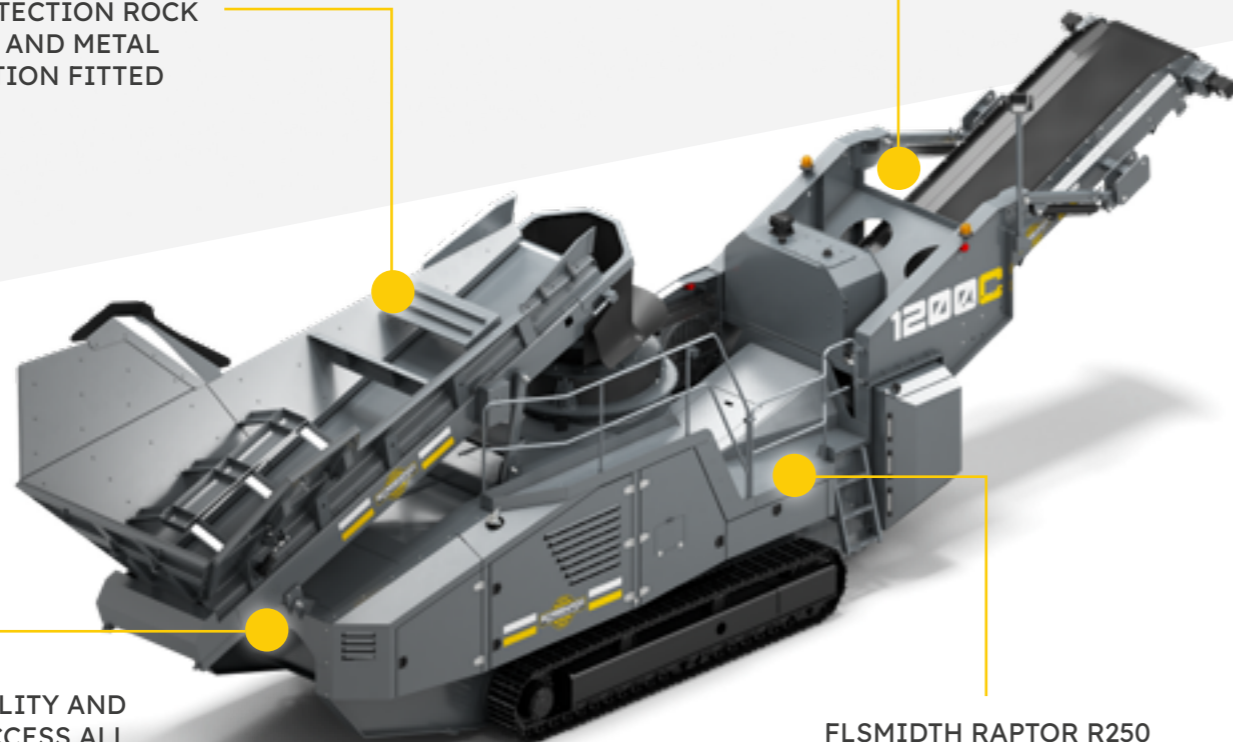

ACCESSIBILITY AND EASE OF ACCESS ALL AROUND WITH QUICK SETUP AND TIMED PREHEAT AS STANDARD

FLSMIDTH RAPTOR R250 CONE CHAMBER

1200C

MAX FEED SIZE	TONNAGE	HOPPER SIZE	FEED OPENING	WEIGHT
235MM 9.25"	UP TO 250 TPH	8.24YDS 6.3M ³	953mm 37.5"	33,000KGS / 72,752 LBS

VARIABLE SPEED HEAVY DUTY BELT FEEDER WITH IMPACT BED

RECIRCULATING SCREENBOX SYSTEM WITH 2 DECKS 12' X 5', WITH RADIAL FUNCTION TO STOCKPILE ON OVERSIZE CONVEYOR

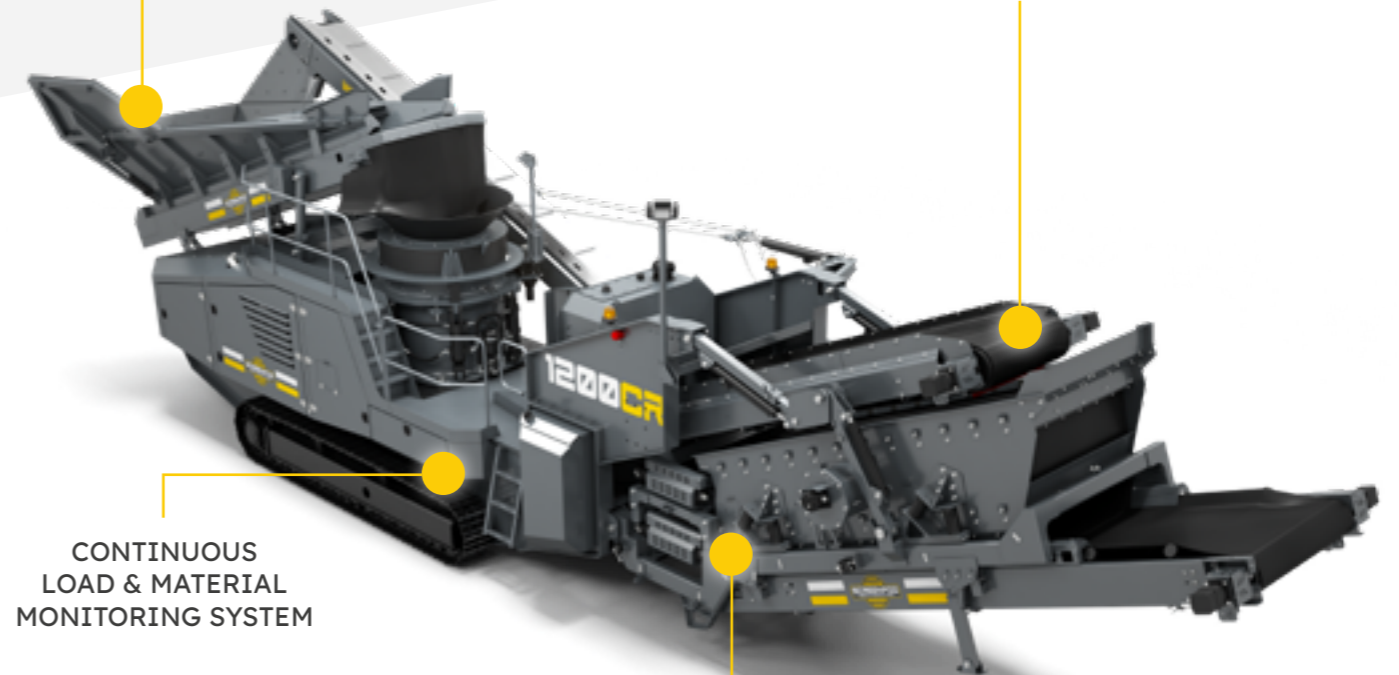

CONTINUOUS LOAD & MATERIAL MONITORING SYSTEM

CAT OR CUMMINS ENGINE OPTIONS

OPTIONS

- RECIRCULATION PACKAGE
- HOPPER EXTENSIONS
- BELT SCALE
- LIGHT MAST AND CABINET LIGHTS
- VARIOUS CONE LINER OPTIONS



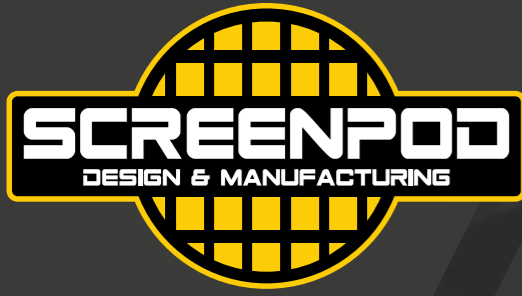

SOLUTIONS DESIGNED
TO PROMOTE A CIRCULAR ECONOMY



www.screenpod.co.uk



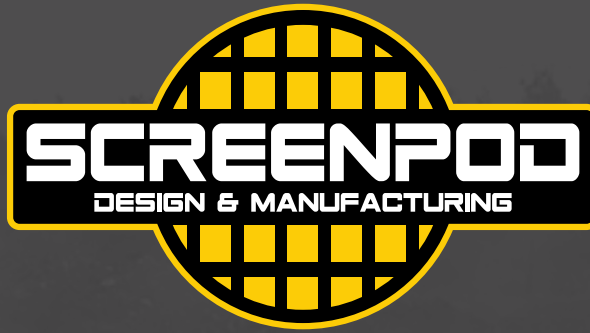

HEAVY LINE

Crushers | Screeners | Trommels | Conveyors



DEALER INFO

 30 Tullyodonnell Road, Dungannon,
Co. Tyrone Northern Ireland BT70 3JE

 +44 (0) 28 8775 8944

 sales@screenpod.co.uk

 www.screenpod.co.uk



SEE ALSO
[SCREENPOD ENVIRONMENTAL RANGE](#)