

SCREW CONVEYORS



AROLCO
ENGINEERING SOLUTIONS



WORKING WITH AUGERS

TYPICAL APPLICATIONS:

- WASTE (ASH, SEWAGE)
- RECYCLING
- FOOD PROCESSING & HANDLING
- MATERIALS HANDLING (QUARRYING/CONCRETE/ TIMBER)
- AGRICULTRE (ANIMAL FEED, PEAT DISPENSING)
- PACKAGING (PLASTIC EXTRUSION)

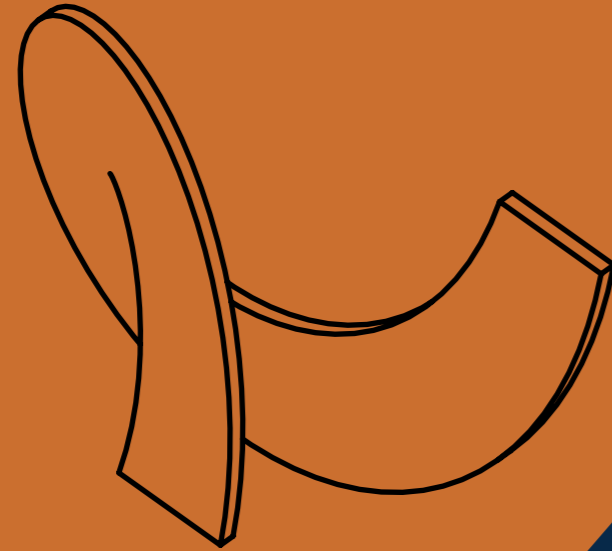
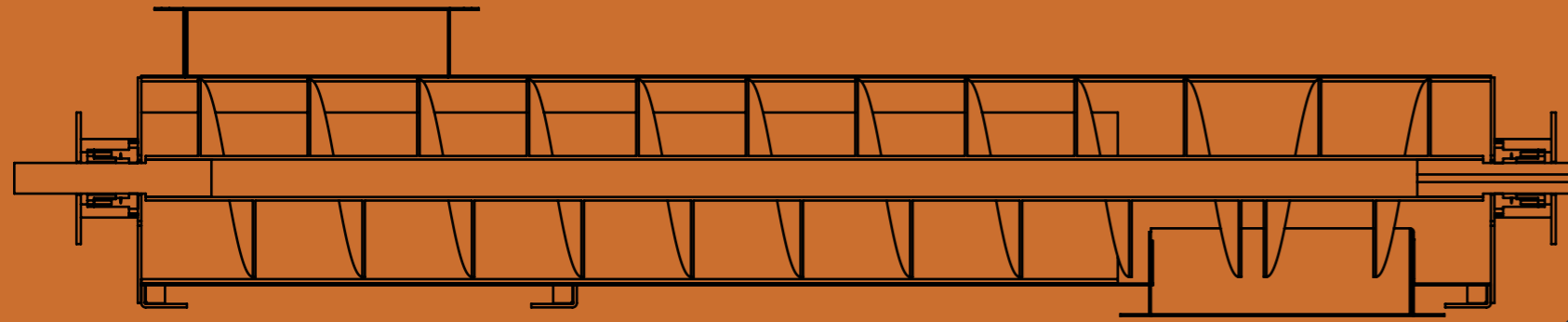

Types of Screw Conveyors

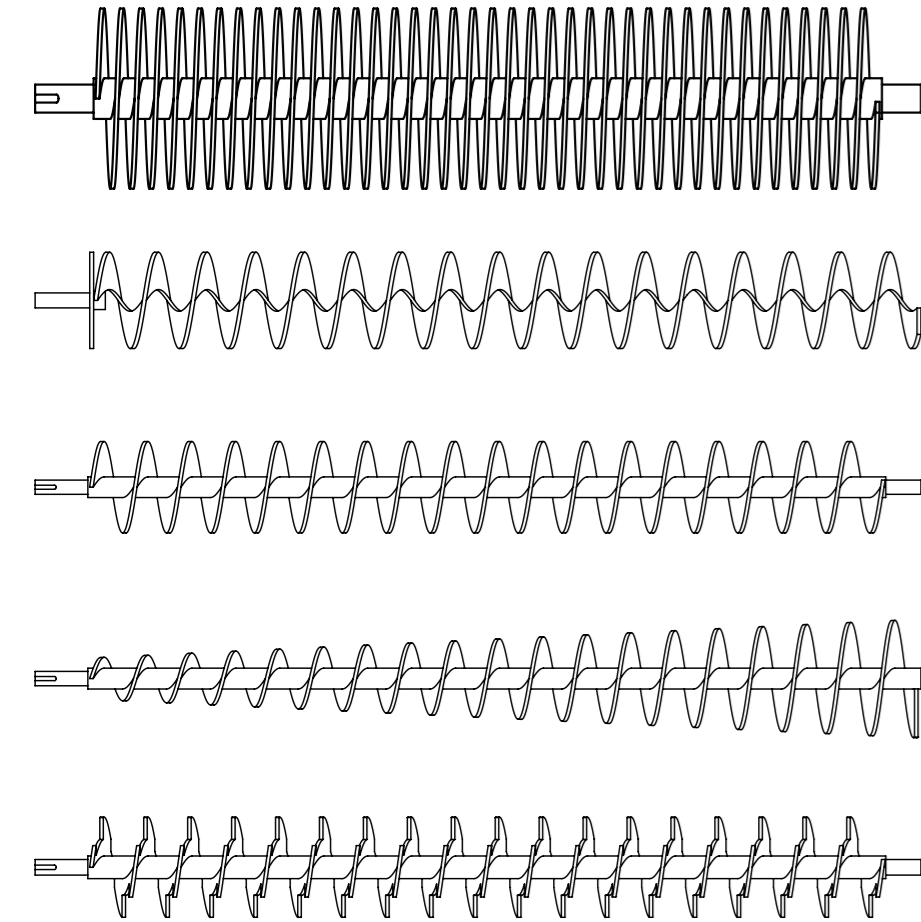

SHORT PITCH
CENTRELESS
STANDARD
TAPERED
NOTCHED

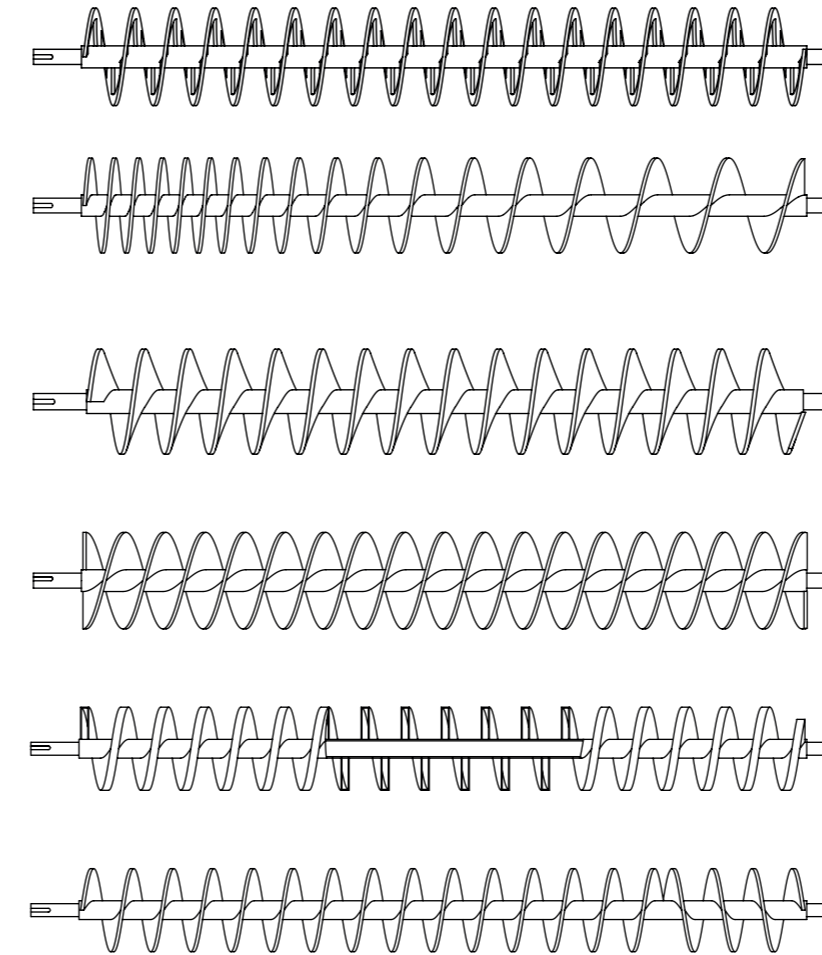

THIN RIBBON
VARIABLE PITCH
CANTED
DOUBLE START
HOLLOW FLIGHT
REVERSED FLIGHTS

3D MODELS & INDUSTRY EXAMPLES

"Whether you are planning for scheduled maintenance or in the middle of unexpected downtime - we will help keep your operations running smoothly with high quality screw conveyors" - Liam Patton, Technical Sales Engineer at Arolco Engineering Solutions

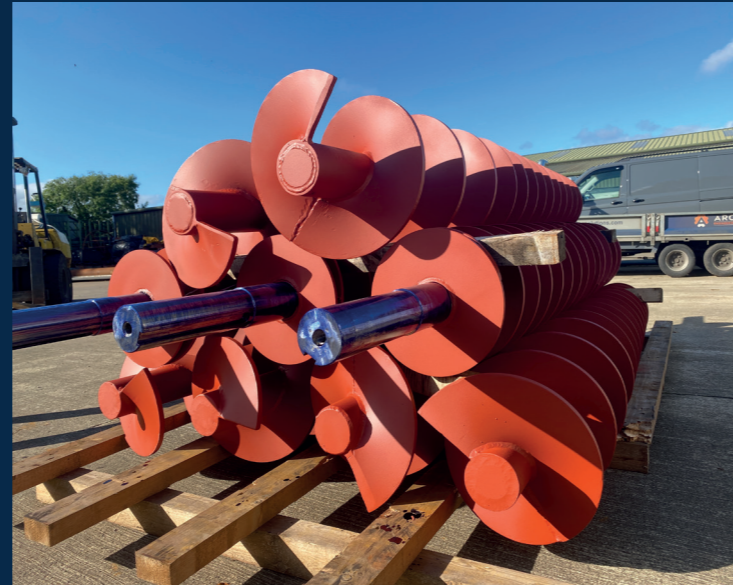
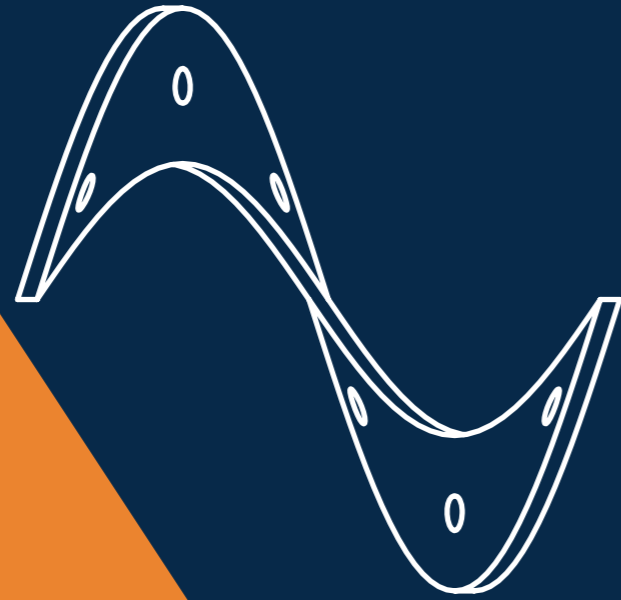



OTHER PARTS AND SERVICES

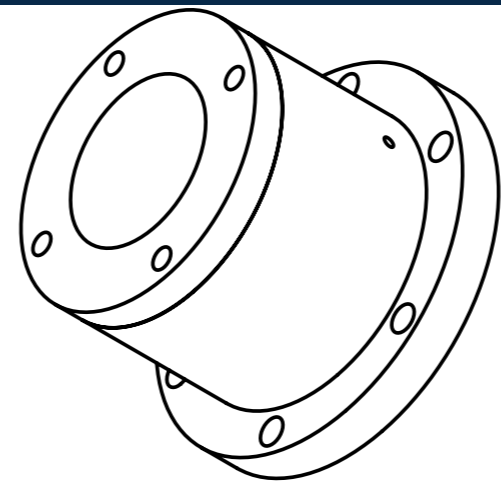
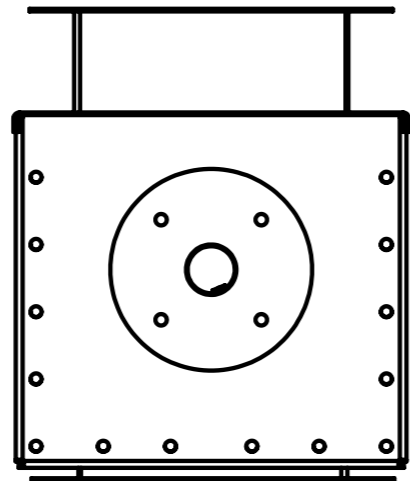
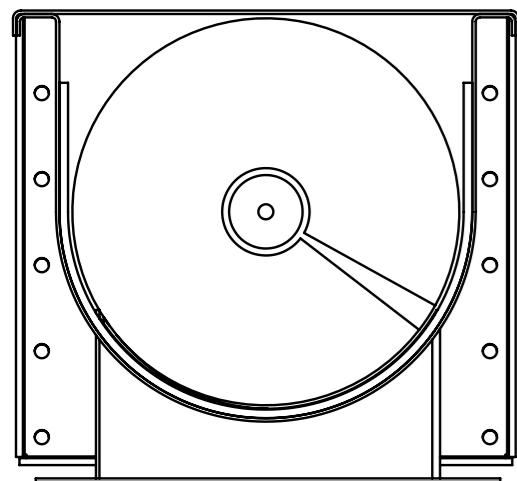

Arolco Engineering Solutions provide a range of complimentary products and services for customers with auger based applications:

- Troughs
- Liners
- Flight Segments
- Hoppers
- Sealing Glands/Stuffing Box
- Hard Facing
- Replacement Bolt On Hardox Wear Parts

AROLCO ENGINEERING SOLUTIONS PROVIDE A QUICK TURNAROUND TIME ON AUGER REFURBISHMENTS

- *JOURNAL REPAIRS*
- *SHAFT REPLACEMENTS*
- *FLIGHT REPLACEMENT*

FOLLOW US ON SOCIAL

@AROLCOENGINEERING





AROLCO

ENGINEERING SOLUTIONS

TURNING THE WHEELS OF INDUSTRY

WEB: arolcoengineeringsolutions.com

EMAIL

sales@arolcoengineering.com

PHONE

02881672800

ADDRESS

60 Knockbrack Rd, Castlederg, Co.Tyrone, BT817LU