

The logo for PEMO PUMPS features the word "PEMO" in a bold, orange, sans-serif font, enclosed within a thick orange rounded rectangular border. To the right of this border, the word "PUMPS" is written in the same orange, bold, sans-serif font.

# PEMO PUMPS



## TECHNOLOGY FOR THE TRANSFER OF SLURRIES

- ABRASION RESISTANT
- ACID RESISTANT

# PEMO PUMPS Optimum Pumping Performance for Abrasive & Corrosive Slurries

## PEMO PUMPS



PEMO PUMPS, headquartered in a 12.000 m<sup>2</sup> factory complex in Vimodrone - Milan, Italy, is world renowned for designing and manufacturing customized centrifugal pumps for the most difficult abrasive and/or acid applications.

Since opening our doors in 1947, we have built and shipped over 40.000 pumps. We have representatives and agents selling PEMO pumps around the world including Spain, Portugal, France, Holland, UK, Poland, Germany, Egypt, South Africa, Russia, Dubai, Singapore, India, South Korea, Vietnam, USA, Mexico, Brazil, Perù, Chile and Australia.

In a strategic effort to support our existing customer base, broaden our market position in America, and achieve future growth on the continent, we have decided to open our subsidiaries in USA and Brazil.

## MAIN APPLICATIONS



### Built Rugged for Exceptionally Long Life in Tough Applications.

- **Mining, Aggregate, Quarry & Mineral Extraction:** PEMO pumps are commonly used to feed hydro cyclones and transfer slurries in these applications.
- **Filter press feeding:** thanks to the unique Double and Triple Stage design, PEMO pumps stand alone in the filter press feed industry.
- **Stone Processing:** since 1947 PEMO Pumps have been totally changing the way to process marble and granite blocks.
- **Ceramic industry:** PEMO is a world leader for pumps that transfer Ceramic slip, Glaze and Ceramic Powder.
- **Biogas plants:** PEMO PUMPS non clogging technology allows to transfer biomass material such as OFMSW or liquid manure to storage and decantation tanks, to load separators and feeding digesters.
- **Chemical Process:** PEMO PUMPS are widely used in the oil and gas, precious metal refining, chemical manufacturing, fertilizers production, pharmaceutical and food and beverage industries.
- **Steel Mills:** heavy duty slurry pumps for transferring hot water up to 100°C (180 °F) containing oil and metal particles.
- **Power Plants:** PEMO pumps are used for coal slurries, fly ash, and SO<sub>2</sub> scrubbers.





# **PEMO PUMPS** Custom Designed, Precision Engineered and Manufactured with a Wide Selection of Material & Configuration Options

## **IMPELLERS**



- Semi-open type: typically made of a metal core coated with a thick layer of various types of rubber.
- Metal Type: Hardalloy PEMO (750-800 HB), AISI, Duplex or Super Duplex and Hastelloy C.
- Additional materials are available on request.

## **CASINGS**



- Built with split case design.
- Made mostly of cast iron. Some models are available in Hardalloy PEMO, stainless steel, Hastelloy or other metals.
- For rubber-lined versions, the interior is protected with vulcanised or separable lining with different compositions depending on the properties of the slurries.

## **EXTENSIVE RANGE OF PUMP MODELS & CONFIGURATIONS**



- 30 basic models of pumps are available in Vertical, Horizontal, Submersible and Multi-Stage versions, for a total of more than 3.000 different custom designs and configurations.
- Capacities range from 1 to 2.000 m<sup>3</sup>/h (5 to 8.800 gpm).
- Head for single-stage pumps can reach 90 m (300 ft) in the Hardalloy PEMO versions.
- All shafts, bases and bearings are over-sized to extend pump life.
- Complete pump packages are compact, with an industrial grade design.

# PEMO PUMPS Pemo Horizontal Pump Design

## AO/TI and AO/TD SERIES



- Designed for heavy duty slurry and/or acid applications.
- End suction pumps with single or double mechanical seals.
- Capacities from 1 to 2.000 m<sup>3</sup>/h (5 to 8.800 gpm).
- Maximum discharge pressure should not exceed 4 bar (60 psi).

## AO/AB SERIES



- Designed for slurries and/or acid applications.
- The heart of the PEMO product line, the AO/AB Series pumps are truly unique. Due to the side inlet, the maximum pressure the mechanical seal will see is the fluid inlet pressure, greatly increasing life of the seal.
- When pumping acid liquids, the shaft and the mechanical seal housing can be made of special alloys.
- Maximum particle size is 2 mm though this is dependent on the specific application.
- Capacities from 1 to 2.000 m<sup>3</sup>/h (5 to 8.800 gpm).
- Maximum discharge head is 90 m (300 ft) in the Hardalloy PEMO design.

## AO/AB/DC SERIES and AO/AB/TC SERIES (double and triple stage versions)



- Designed for slurries and/or acid applications.
- The AO/AB/DC Series and AO/AB/TC Series are the perfect solution for feeding filter press or ceramic spray dryer and slurry transfer.
- When pumping acid liquids, the shaft and the mechanical seal housing can be made of special alloys.
- Maximum particle size is 1 mm, though this is dependent on the specific application.
- Capacities from 5 to 1.000 m<sup>3</sup>/h (22 to 4.400 gpm).
- Maximum discharge head is 180 m (590 ft) in the Hardalloy PEMO design.



# PEMO PUMPS Pemo Vertical Pump Design

## VEC SERIES



- Designed for heavy duty slurry and/or acid applications.
- The VEC Series pumps are custom built to customer specifications.
- The shaft is always supported above the baseplate by two bearings inside the base.
- The pump-motor coupling is an elastic joint or V-belt. The maximum length of the pump under the base can reach 5 meters (16 ft).
- Using a sleeve bushing as the sealing system, the VEC Series pumps cannot run dry under a certain level.
- Capacities from 5 to 1.500 m<sup>3</sup>/h (22 to 6.600 gpm).
- Maximum discharge pressure up to 7 bar (100 psi).

## MEC SERIES



- Designed for heavy duty slurry and/or acid applications.
- The MEC Series only has direct transmission by means of an elastic joint. There is always a metallic structure around the motor with a lifting eyebolt at the top.
- Lengths under the bases are standard and do not exceed 2 meters (7 ft).
- Using a sleeve bushing as the sealing system, the MEC Series pumps cannot run dry under a certain level.
- Capacities from 5 to 1.500 m<sup>3</sup>/h (22 to 6.600 gpm).
- Maximum discharge pressure up to 7 bar (100 psi).

## AUS SERIES



- Designed for heavy duty slurry and/or acid applications.
- The AUS Series pumps can run dry since there is no mechanical seal.
- Mechanically speaking these pumps are the same as the VEC series, but the maximum length of the AUS Series pump under the base seldom exceeds 2 meters (7 ft).
- Usually the fluid inlet is above the casing but in some versions it is also near the bottom (double sided impellers).
- The AUS Series pumps can be installed inside or outside tanks.
- They can be used to pump abrasive and/or acid liquids.
- Capacities from 5 to 1.500 m<sup>3</sup>/h (22 to 6.600 gpm).
- Maximum discharge pressure up to 7 bar (100 psi).

**SUBMERSIBLE PUMPS**



- Designed for heavy duty slurry applications.
- The standard PEMO submersible pumps are manufactured with power ranging from 1,1 to 75 kW, and speeds from 735 to 3.500 rpm.
- Standard capacities up to 700 m<sup>3</sup>/h (3.100 gpm).
- Maximum discharge pressures up to 7 bar (100 psi).
- Casings are rubber lined or made of Hardalloy PEMO.
- All the mechanical seals are made of Silicon or Tungsten Carbide.
- Bearings are grease lubricated and made to deliver long-life.
- All PEMO Submersible pumps are provided with thermal probes (for the control of motor temperature), and one oil level probe (for slurry leak detection inside the oil chamber).
- PEMO Submersible pumps all are sold with an electric device for the analysis of the signals from probes.

**PEMO HYDROCYCLONES**

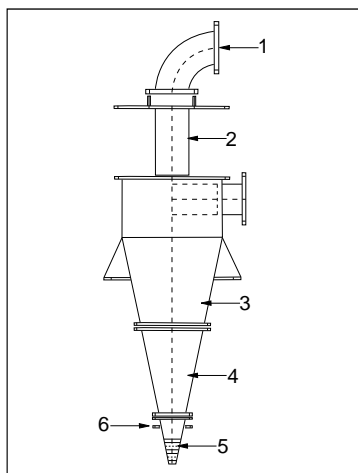

- Coated internally with rubber, polyurethane or ceramic, PEMO Hydrocyclones consist of modules that can be assembled in manifolds to obtain different sizes.
- Flows for PEMO Hydrocyclones range from 50 to 500 m<sup>3</sup>/h (220 to 2.200 gpm) with a maximum working pressure inlet of 2 bar (30 psi).

**POWDER DISSOLVER**



- The Perissinotto Powder Dissolver was designed to create a density-controlled liquid solution out of any type of dust soluble in water or other liquids. Its applications range from dust coming from dust filters, hydrocyclones on spray dryers, colored oxides, and recycled dusts.

## PEMO RESEARCH & DEVELOPMENT

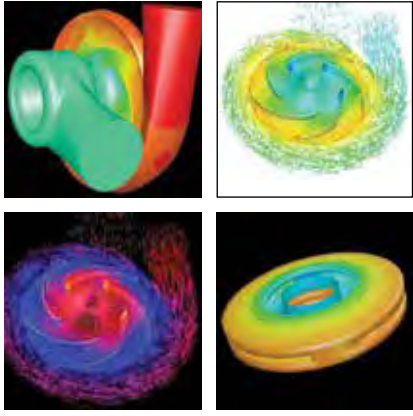

- Every year 4-5% of all sales income is invested for research and development.
- Continuous interaction with our customers and suppliers.
- Fluid Dynamic studies.
- Constant research on new materials.
- Continual revision and update of existing pump models.
- Introduction of at least one new model every year.

## PEMO AFTER SALES SUPPORT

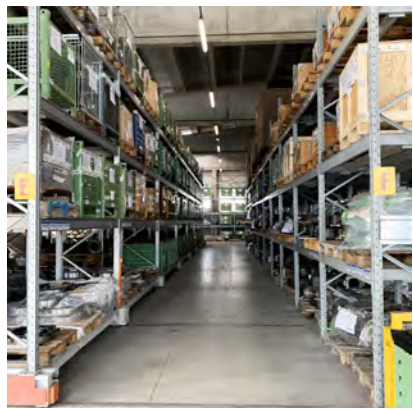

- Rugged PEMO pumps provide long reliable service. We have customers that are still buying spare parts for pumps manufactured more than 40 years ago. Because of this we are committed to the availability of spare parts for the complete life of every one of our pumps.
- Our attention to the customers starts before a pump is sold. As soon as a quotation is requested, we carefully check the customer's submitted specifications to identify the optimum pump solution for their application.
- PEMO customers know they can rely on our effective after-sale service. We have more than 9.000 pump components and spare parts continually in stock, and our state-of-the-art inventory system allows parts to be picked and shipped with very short lead times. In fact, 90% of our spare parts orders are shipped within one week.



**THE TOUGHEST  
PUMPS  
IN THE WORLD**

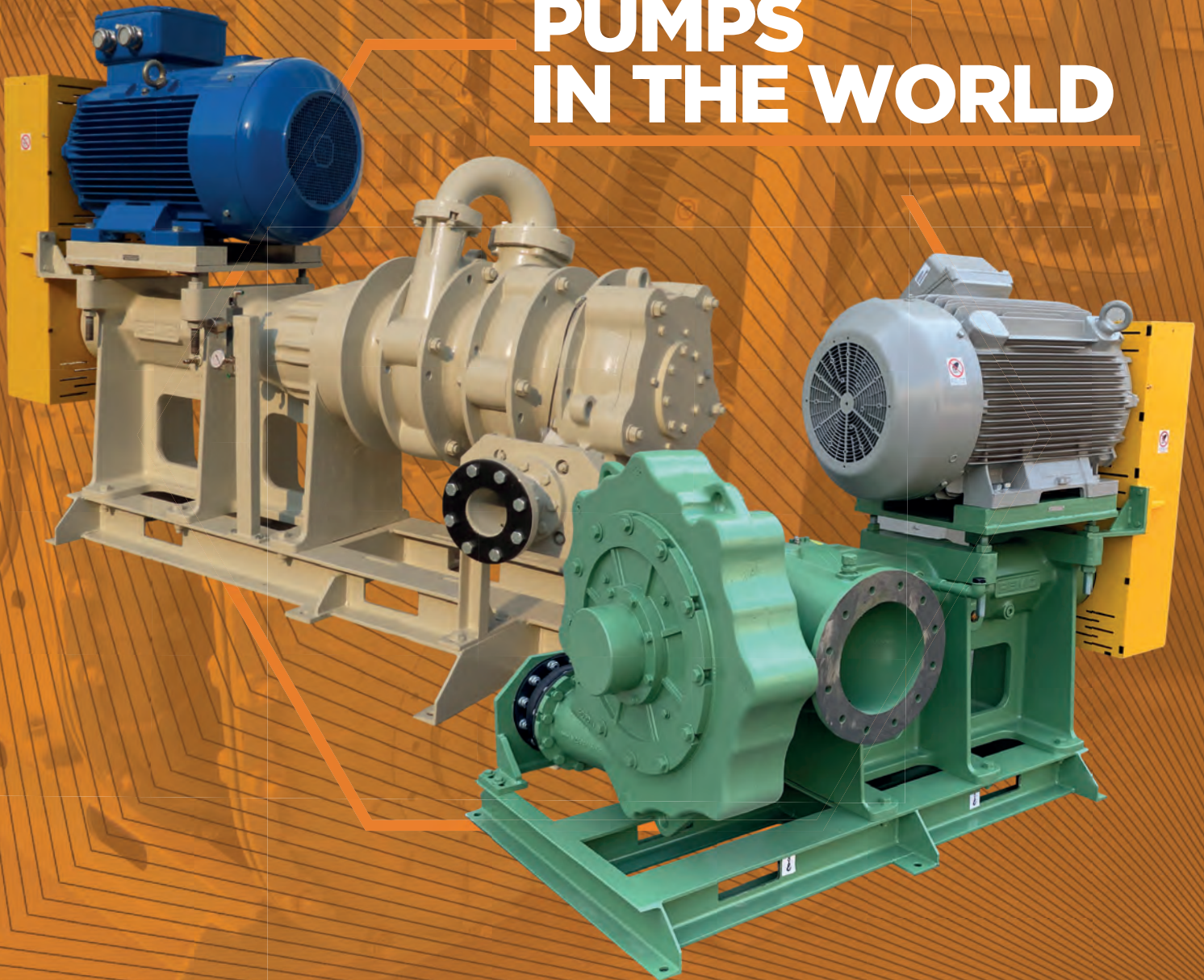

**WWW.PEMOPUMPS.COM**

+39 02250731  
peris@pemo.com

**Perissinotto s.p.a.**

**PEMO PUMPS**  
Via Pascoli 17, 20055  
Vimodrone (MI) ITALY