

# IT Cooling

Highly efficient and reliable cooling solutions



# A new generation of **IT Cooling technology**

We are all becoming more and more reliant on technology. Most businesses depend on their IT systems to provide the data they need, 24/7, year after year, as even the shortest outages can cause significant disruption and loss of revenue.

It is imperative that these vital IT servers and equipment are always kept in optimal conditions, with effective cooling being paramount. The new range of Computer Room Air Conditioning (CRAC) and Computer Room Air Handling (CRAH) systems from Mitsubishi Electric combine the latest in DX Technology with the RC brand's expertise in IT cooling. These innovative, energy efficient systems can effectively deliver robust solutions to IT environments with ease.

DX Computer Room Air Conditioning solutions from Mitsubishi Electric offer a range of high sensible systems, specifically designed to provide close control of temperature and humidity; perfectly suited for small to medium sized enterprise data centres.

Mitsubishi Electric purchased the RC Group in 2015, enhancing our product line up and marking our full scale entry into the IT cooling market.

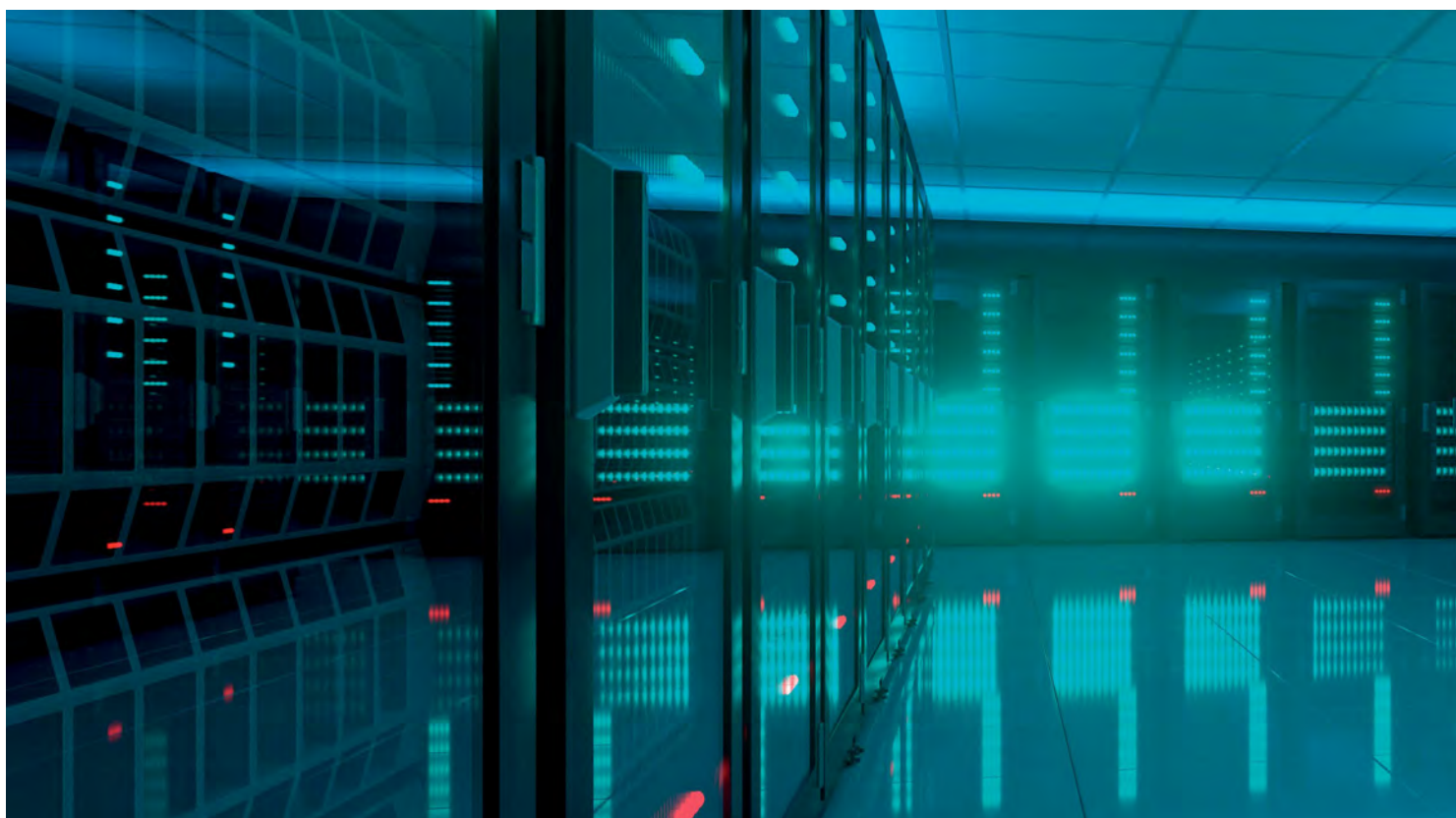



RC is a strong European brand supported by 50 years of customer trust and high quality production, and its range of energy-saving, low-noise and innovative IT cooling technology further expands our application and customisation capabilities.

## Mitsubishi Electric is the first name for **comfort and efficiency**

Founded in 1921, Mitsubishi Electric is now a global, market leading environmental technologies manufacturer. In the UK, the Living Environment Systems Division provides pioneering solutions that heat, cool, ventilate and control our buildings in some of the most energy efficient ways possible.

Through our technical expertise, long experience and innovative product range, we enable building operators everywhere to significantly improve energy efficiency, reduce running costs and adhere to increasingly tough legislation. We believe that global climate challenges need local solutions.

Our aim is to help individuals and businesses reduce the energy consumption of their buildings and their running costs.

At Mitsubishi Electric, we offer advanced technology that really can **make a world of difference.**



# The need for IT Cooling

## Precise temperature and humidity control

More and more businesses are opting to store their data on-site in enterprise data centres, and in the past standard wall mounted split systems may have been an option to cool this type of application.

However, complex IT environments are often characterised by variable cooling loads, which require a high cooling capacity at full load in order to allow the IT equipment to operate correctly when it is most needed.

## The perfect match between efficiency and reliability

The need for high sensible cooling and close control of both temperature and humidity in critical IT environments has therefore never been higher, and this is where our new range of specialist IT cooling systems makes it possible to keep temperature and humidity constant, even with very wide load variations, ensuring the correct room conditions all year round.

With our IT cooling systems, both efficiency and reliability are paramount throughout all the stages of research, design and manufacturing. By using this approach, along with over 50 years of manufacturing experience within the IT cooling sector, we are able to offer tailor made IT cooling solutions that have been designed to fulfil this requirement, reducing operational costs in the process through the use of highly efficient technology.

## Mitsubishi Electric close control cooling systems

Mitsubishi Electric's close control systems are specifically designed for rooms with a high sensible cooling load that require precise temperature and humidity control.

Because of the need for close control 24 hours a day, 365 days a year, an inverter driven compressor has been incorporated into many of the outdoor units, maximising the energy efficiency of each system. Features include:

- DX or chilled water versions
- Precise temperature and humidity control
- High Sensible cooling
- Easily integrates into existing and new control networks
- Back-up and rotate functions
- Inverter driven capacity control
- New generation EC PUL (Polymeric Ultralight) high efficiency fans
- Free cooling
- Dual fluid circuits available for the highest reliability

## Designing the optimum IT cooling system

Two factors need to be taken into account when designing the perfect system for IT cooling: density and capacity. Mitsubishi Electric's wide range of products allows you to choose the correct balance of these factors, in order to meet your individual application requirements.

Mitsubishi Electric's range of dedicated IT cooling equipment includes DX systems specifically designed for IT applications, and for those who are familiar with the benefits and installation processes of our existing Mitsubishi Electric HVAC outdoor units. This opens up new opportunities for the application of DX systems in critical IT environments.



## Density - Low / Medium / High

When considering the type of air conditioning required for an IT cooling application, one of the most important factors to consider is density.

### What does density mean?

The density of an IT cooling application describes how much cooling power is required to remove the heat produced by the IT equipment or machinery in a given space.

For most IT cooling applications, the 'space' is a computer rack, which is a physical chassis that can house multiple computers, or servers. A computer rack is also known as a server rack or computer cabinet.

To characterise the density, the cooling power required to maintain the temperature in the rack must be calculated.

For IT cooling applications where the cooling power required in a single rack is less than 5kW, this would be described as **low density**.

Where the cooling power required is between 5-15kW, the density of the rack would be described as being **medium**, and where greater than 15kW, described as **high**.

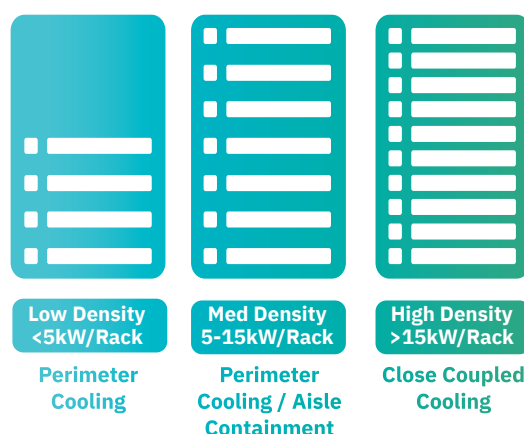

### Selecting the right system

In low density applications it is possible to maintain temperatures in the rack by controlling the room temperature as a whole, using perimeter air conditioners.

However, as the density of the rack increases, the risk of localised areas of the data room overheating also increases, and these 'hot spots' must be removed to ensure IT equipment isn't damaged through overheating.

To remove the risk of hot spots in higher density applications, localised cooling is installed closer to the racks to ensure the cooling is delivered where it's needed most.



### Low Density Applications

Computer room air conditioners, known as CRAC units, are located around the perimeter of the data room.

These systems draw warm air in from the racks, while cooler conditioned air is then typically blown under a raised floor and out through grilles to the front of the server racks, to create hot and cold aisles within the data room.

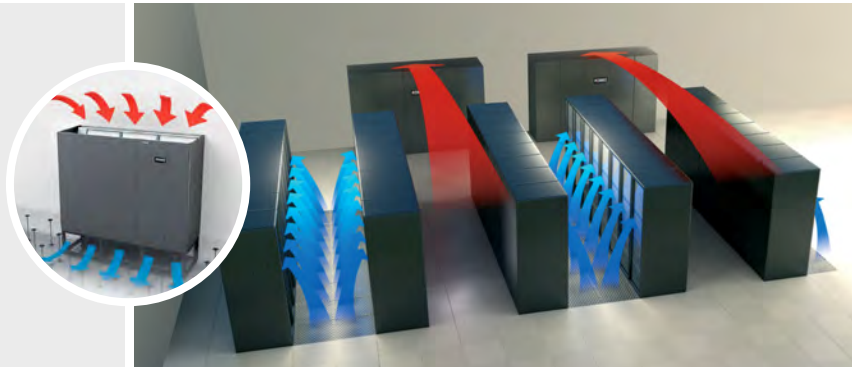

### Medium Density Applications

Perimeter CRAC units are combined with aisle containment for medium density applications. In this type of system, the cold and hot air streams are physically separated to ensure they do not mix, and to prevent hot spots from occurring.

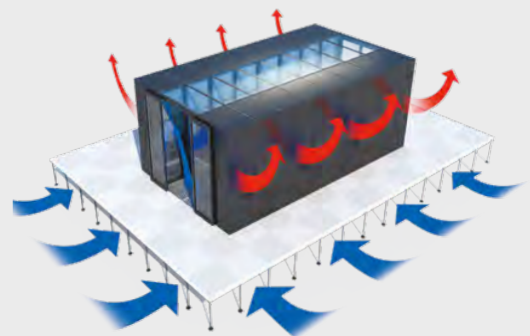
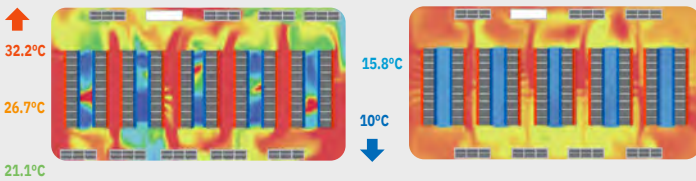

### High Density Applications

For the highest density applications, the addition of localised cooling can meet the heavy demands of the system. In-row, in-rack or rear door coolers are used to bring the conditioned air right up to the server inlet, ensuring the servers within the rack are maintained at optimum temperature. **This is commonly referred to as close coupled air conditioning.**



# Capacity - Small to Large Scale Applications

Another factor that will dictate the type of equipment required for an IT cooling application is the total capacity of the data centre.

## Small Capacity Applications

**Smaller capacity applications** are commonly designed with more cost effective and simpler direct expansion (DX) technology. DX equipment doesn't require the installation of water pipework or the need for 3rd party ancillaries, such as pumps and control valves, making them a convenient solution for smaller projects.

Historically, contractors may have chosen to install comfort cooling air conditioning products in these types of applications. While these products offer a solution, a more targeted approach is often required, and as such we have developed the M Series **MSY-TP** wall mounted system, which has been designed specifically for high sensible cooling.



MSY-TP

5kW - Small

## The Gap in Capacity

**As system capacity increases, it becomes impractical to install a large number of small wall mounted systems. However, at the same time the application doesn't lend itself to apply highly specialised IT cooling equipment.**

This is where the **s-MEXT DX** comes in; it uses the same ethos of 'plug and play' as our Mr Slim split-system technology, and helps fill the gap between low and high capacity applications, without any upskilling requirement.



s-MEXT DX

50kW - Medium



## Large Capacity Applications

For **large capacity applications** customers and installation contractors would usually opt for highly specialised applied products. Applying these products requires a high level of design and product knowledge.

Usually these products are bespoke and are typically installed by specialist IT cooling contractors.

DX technology is utilised in this arena, however in these larger applications, technology that uses chilled water becomes more prevalent. These systems, while being higher in terms of CAPEX, can offer increased efficiency through the use of free cooling and higher operating temperatures in the data centre, where running costs are more important to manage.



i-NEXT DX / w-MEXT / w-NEXT

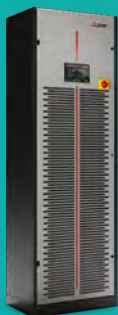

100kW - Medium



i-NEXT DX / w-MEXT / w-NEXT



Multi Density

200kW - Large



RCWall



400kW - Large

# Low Density / Low Capacity Applications

## The need for high sensible cooling

Dedicated IT cooling equipment provides many benefits for small, low density IT cooling applications. Although comfort cooling systems can be convenient solutions, specific I.T Cooling systems are strongly recommended where there is a need for high sensible cooling.

The total cooling capacity of any air conditioning unit is comprised of "**sensible cooling**" and "**latent cooling**".

**Sensible cooling** is the ability to remove heat that causes a change in temperature, but no change in the moisture content

**Latent cooling** is the ability to remove moisture from the surrounding environment

The cooling capacity stated for a comfort cooling air conditioning unit is usually its total cooling capacity (i.e. sensible + latent). Latent cooling is important in comfort cooling applications due to the presence of people in the space, who will produce moisture in the air and increase the humidity levels.

However, in a data centre, the electronic equipment generates only dry heat (no moisture), so the sensible cooling capacity becomes the most useful value. The common way to define this is to use the sensible heat ratio (or sensible heat factor) which is expressed as:

$$\text{Sensible Heat Factor (SHF)} = \frac{\text{(Sensible Cooling)}}{\text{(Total Cooling)}}$$

For comfort air conditioning, the SHF is typically between 0.60 and 0.70; the coil/airflow is designed to remove 60% to 70% sensible heat load and 30% to 40% latent heat load (moisture). The cooling equipment used in a data centre is designed for an SHF between 0.85 and 0.95; that is 85% to 95% sensible heat load and 5% to 15% latent load. These cooling units will effectively remove the high sensible heat load produced by the electronic equipment in a data centre.

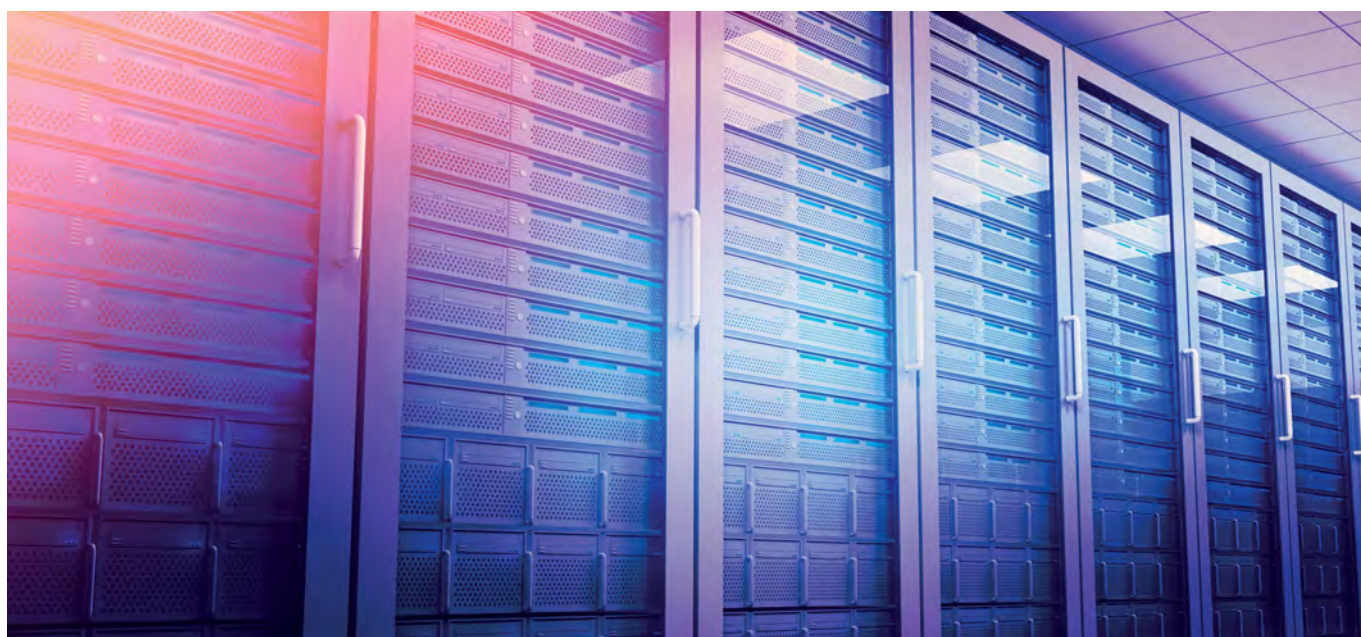

## M Series MSY-TP R32 High SHF Wall Mounted System

The M Series MSY-TP wall mounted system blends energy efficiency with a modern white design.

This cooling only unit has a high sensible cooling capacity, making it ideal for low density / low capacity computer rooms or areas that require a greater degree of sensible cooling.



- High sensible cooling capacity
- Cooling down to -25°C outdoor air temperature
- Highly energy efficient
- Weekly timer for greater control of scheduling
- Utilises lower GWP R32 refrigerant

The MSY-TP unit has a high SHF alongside a high Seasonal Energy Efficiency Ratio (SEER), which when combined, leads to a lower running cost over the course of its lifetime. The MSY-TP is able to achieve a higher SHF through using an oversized evaporator, which is designed for a high Delta T across the coil.

**When compared to a standard comfort cooling air conditioner, the MSY-TP unit offers significant run cost savings over its lifetime.**



Run Cost Comparison of Mitsubishi Electric Wall Mounted Systems - 15 Years

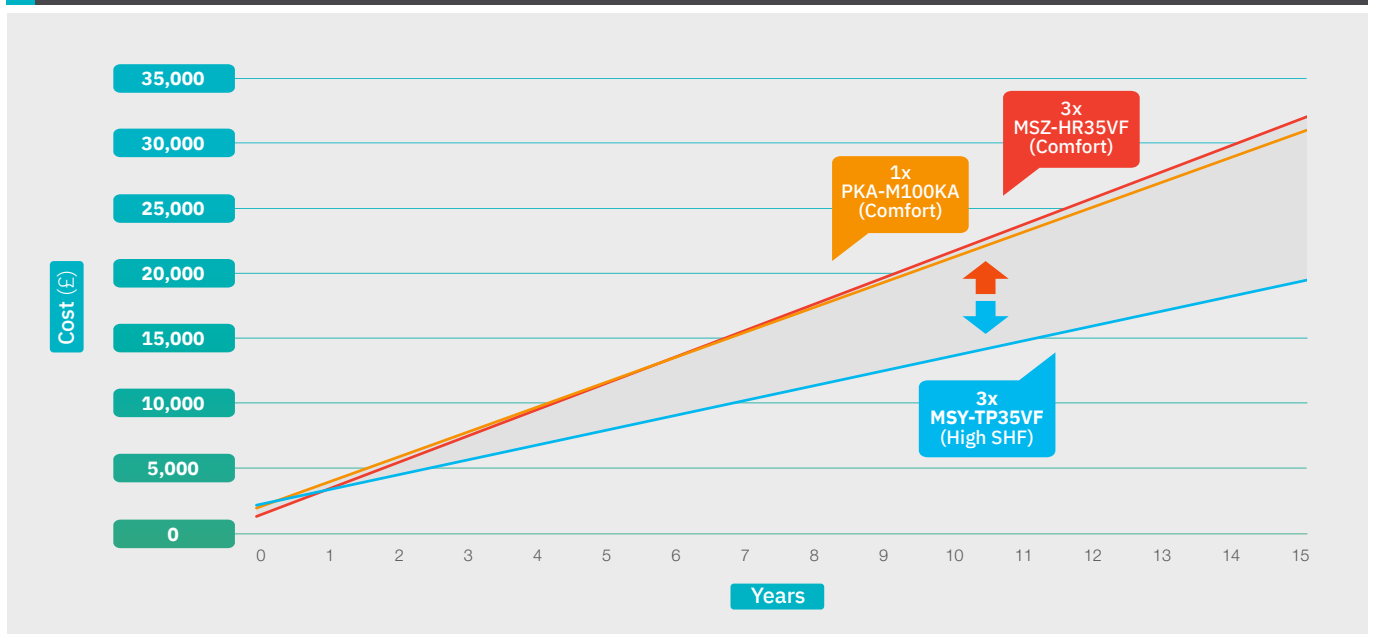

# Filling the Gap: Medium Density / Medium Capacity Applications

## Introducing the s-MEXT DX Close Control System

Computer room air conditioning is ideal for applications where high sensible cooling and close control of temperature and humidity are required.

s-MEXT takes advantage of more than 50 years experience of the RC brand within the IT cooling market, coupled with Mitsubishi Electric renowned quality standards.

The split cooling package consists of the indoor s-MEXT high precision air conditioner connected to a Mr Slim Power Inverter outdoor unit. The result is a full inverter split system, designed according to the best quality standards and dedicated to the most reliable IT environments.

- |  |   |
|--|---|
| Hybrid of packaged and bespoke equipment           | High efficiency   |
| Plug and play technology with up to 100m pipe runs | Full Mitsubishi Electric inverter technology and EC plug fans |
| Reliable and trusted technology                    | 3 years warranty on the indoor unit                           |
| Compact with small footprint                       | Up to 7 years warranty on the outdoor unit                    |

6-42kW in either upflow or downflow configurations 



 s-MEXT DX CRAC Units

 Mr Slim Power Inverter Outdoor Units



# R32



## Trusted Mitsubishi Electric Power Inverter technology

The s-MEXT DX system is able to be connected to either our new lower GWP R32 refrigerant Power Inverter outdoor units, or its R410A version. The use of a Power Inverter outdoor unit simplifies the installation process, removing the need for oil traps and double risers and allowing pipe sizes to be easily calculated.

Developed for high-performance operation, **the Power Inverter offers a host of advanced functions:**

- Redundancy functions with automatic switchover in the event of a fault
- 'Easy maintenance' function and automatic refrigerant level monitoring
- Inverter Compressor allows for continuous modulation, achieving a high energy saving performance
- Inverter DC Axial fans

## New generation EC fans

High performing EC fans on the s-MEXT unit are made of polymeric ultralight material in order to ensure perfect airflow modulation at partial loads. **The fans deliver advantages in terms of:**

- Reduction of noise levels by 4-5 dB(A) compared to traditional solutions
- Reduction of the absorbed power by 25% compared to traditional solutions



## s-MEXT DX Close Control System

### ■ Harnessing the highest capacity into a compact footprint

s-MEXT controls temperature and relative humidity with pinpoint accuracy, even in the case of very strong thermal variations. Brilliantly engineered to deliver top-class efficiency values, the indoor unit features a range of premium quality components, such as EC plug fans, an evaporating coil with hydrophilic treatment and a PID microprocessor control system.

A wide selection of accessories are also available to suit the most critical installation requirements.

The fact that the compressor is contained in the outdoor unit allows for a compact s-MEXT footprint when compared to standard CRAC units, freeing up valuable space in the data centre.

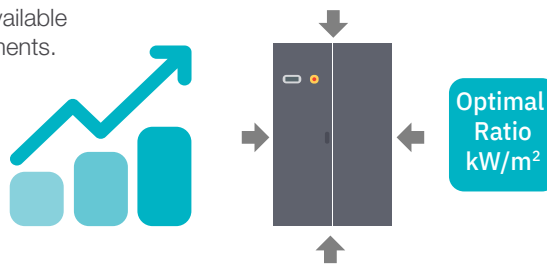

### ■ Extended pipe runs and lift

By combining the s-MEXT CRAC unit with the Mr Slim Power Inverter outdoor unit, **pipe runs of up to 100m with a 30m lift** (height difference) are possible.



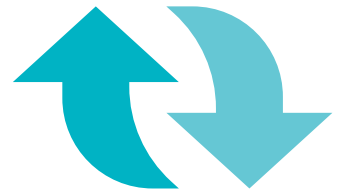

## Airflow options

The s-MEXT is available in two different airflow configurations, ensuring installation flexibility.

### Downflow (under)

With bottom air supply and top return

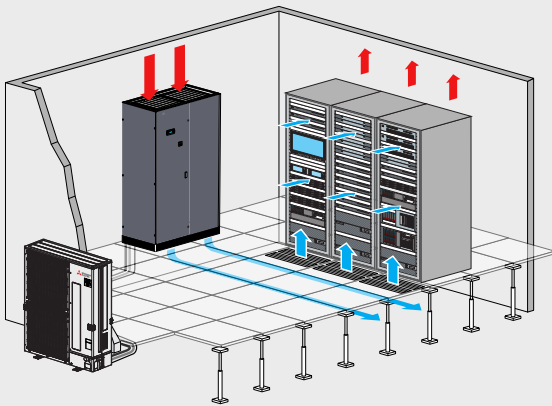

### Upflow (over)

With top air supply and frontal air return

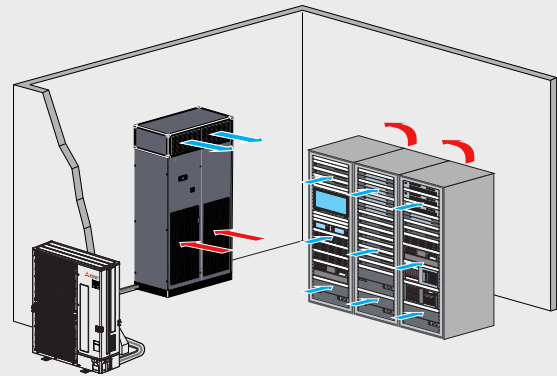

### Warranty

**3 years warranty**  
on the s-MEXT  
indoor unit



up to  
**7 years warranty**  
on the Mr Slim Power  
Inverter outdoor unit



# Medium Density / Large Capacity Applications

## i-NEXT DX / w-MEXT / w-NEXT Close Control Systems

High precision air conditioners are ideal for applications where high sensible cooling and close control of temperature and humidity are required. The i-NEXT DX, w-MEXT and w-NEXT ranges make it possible to keep temperature and humidity constant even with very strong load variations, ensuring premium sensible cooling capacity values.

- Perimeter units with upflow and downflow configurations
- Ultralight composite EC plug fans resulting in reduced noise and power usage
- Integrated control of up to 10 units for intelligent redundancy management
- Automatic restart from power outage
- Return air temperature operating limits up to 40°C
- Optional Modbus RS485 and BACnet TCP/IP connectivity
- Optional electrical heater and steam humidifiers

The **i-NEXT** direct expansion air cooled range is perfect for keeping room conditions constant under varying loads, whilst being highly energy efficient.

The **w-MEXT** and **w-NEXT** are high precision air conditioners designed for IT cooling that utilises a chilled water feed.





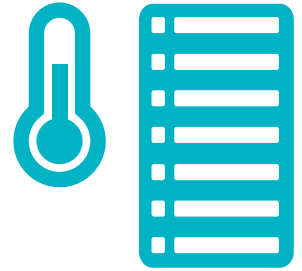

## Precise temperature and humidity control

Complex IT environments are characterised by extremely variable thermal loads, which require a high level of cooling capacity at full load, to ensure the continual efficient and effective operation of IT equipment. The i-NEXT DX and w-MEXT/w-NEXT provide this, ensuring a reliable performance throughout the lifetime of the system.

## Airflow configurations

Like with the s-MEXT DX, both the i-NEXT DX and the w-MEXT/w-NEXT systems are available in both downflow and upflow configurations, ensuring installation flexibility across a multitude of applications.

### Downflow (under)



Air suction is from the top of the unit and air delivery is provided to the underfloor void.

### Upflow (over)



Air intake can be at the front, rear or bottom of the unit, and the air delivery is from the top of the unit, into ducts behind suspended ceilings or from front delivery plenums.

## EC plug fans

Specifically designed for high precision air conditioners, the new EC PUL (Polymeric Ultralight) fans of the i-NEXT DX and w-MEXT/w-NEXT feature a new compact design and an innovative blade geometry, resulting in a higher airflow rate and reduced operating costs. **The advantages compared to standard EC fans are:**



Reduction in noise levels by 4-5dB(A)

20% efficiency increase

## i-NEXT DX Close Control System

The i-NEXT DX air cooled range incorporates full inverter driven BLDC Mitsubishi Electric compressors and a new microchannel coil remote condenser, perfect for keeping room conditions constant under varying loads, whilst being highly energy efficient.

### The best of both worlds:

The i-NEXT is available in both DX only, as well as a Dual Fluid version for maximum resilience, alongside the ability to incorporate free cooling from ambient heat rejection plant.

- Full inverter technology with BLDC Mitsubishi Electric compressors
- Microchannel coil remote condensers with AC axial fans
- Front access for easy inspection and routine maintenance

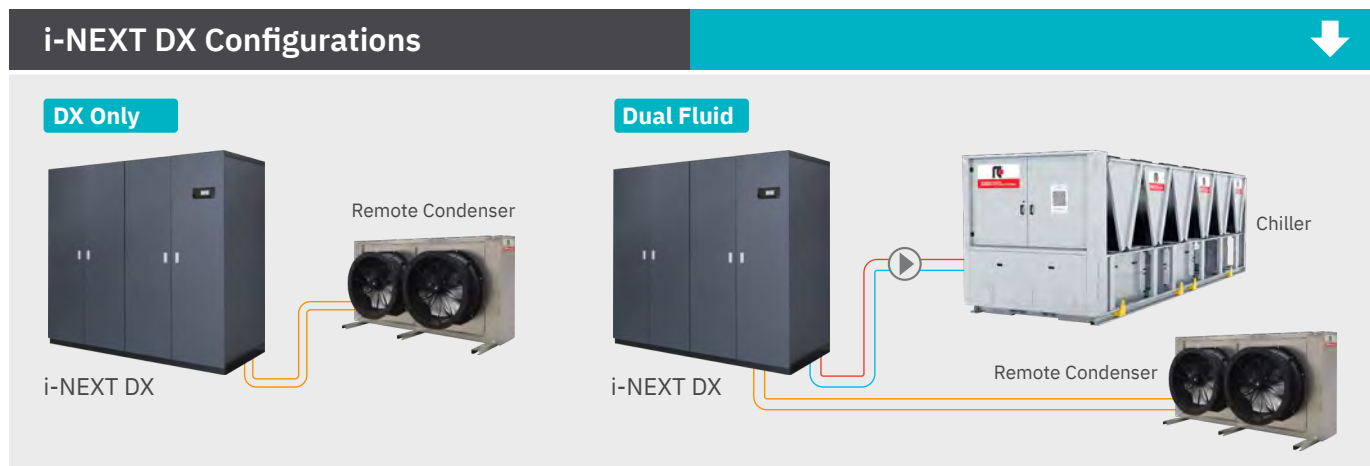

### ■ GR-Z Microchannel Coil Remote Condensers

The GR-Z models are high efficiency remote condensers that can be coupled with the i-NEXT DX close control air conditioning units.

Each condenser features microchannel coils and AC axial fans in order to provide the best-in-class efficiency and higher corrosion resistance. The condensers can be installed either vertically or horizontally and are available as an ultra-low noise version.

#### Key Features

- 50% less refrigerant charge compared to traditional finned coil remote condensers, with up to a 45% increase in heat exchange efficiency
- Microchannel condenser coil consisting of parallel flow aluminium tubes, result in a greater level of heat exchange due to a lower thermal resistance, weight reduction and a lower pressure level
- Stable and efficient operation is achieved thanks to the use of uncoated aluminium blades, dynamic balancing and precise airflow control
- AC Fans include optimised full bell mouth with guiding vane and short diffuser
- Low noise levels are achieved due to the incorporation of AC fans, advanced electronics and sound-proof insulation
- High corrosion resistance on both the aluminium casing and coils



## w-MEXT and w-NEXT Chilled Water Close Control Systems

Ideal for applications where high sensible cooling and close control of temperature and humidity are required. The w-MEXT and w-NEXT chilled water ranges incorporate the latest EC plug fan(s), advanced controls software and an increased coil area resulting in the highest efficiency.

- High Efficiency - EC plug fans
- Small footprint
- Adaptive Set Point
- Active Redundancy
- Available in Upflow (over) and Downflow (under) variants
- High water temperatures
- Integrated temperature control

### w-Mext and w-NEXT Configurations



#### Single Circuit

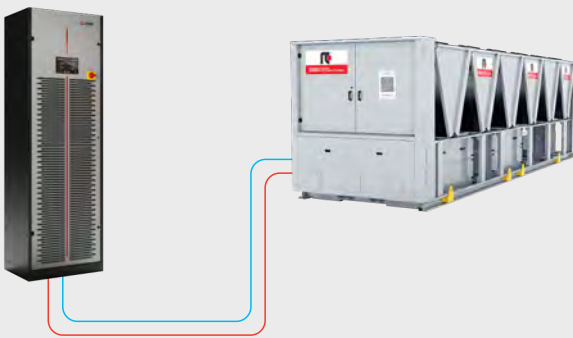

#### Double Circuit

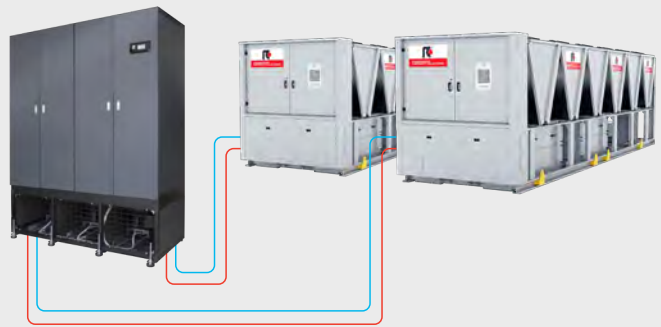

### Single chilled water circuit configuration

Chilled water air conditioners utilise water coming from a single chiller as a means to transfer heat. The liquid flow in the unit's water coil is managed by an internal 2 or 3-way valve.

### Double chilled water circuit configuration

These units are provided as standard with two water circuits that never work simultaneously, as they operate as 100% back up to each other. Such circuits are connected to two different chiller lines, completely independent of one another.

Dual circuit configurations are the perfect solution for applications where **Reliability, Safety** and **Redundancy** are paramount.

# RCWall Chilled Water System

## Computer Room Air Handler (CRAH)

Ideal for high density data centre or hyperscale application where maximum cooling duty with minimum power input is required, resulting in a lower PUE installation.

No false floor required

Modular design - Stackable to achieve x2 cooling capacity without increased footprint

Latest EC fan technology

Flexible connections either side or top to reduce installation cost & time

Dual power and fast restart

RCWall

77-232kW →

RCWall

154-465kW →



Easy access for installation & on-going maintenance



## RCWall Configurations ↓

### Chilled Water System



**Indoor Unit**  
Fanwall chilled water unit  
12 sizes available

### Outdoor Unit

Large Chillers or FC Chillers optimised for high temperature water outlet



Thanks to space saving optimisation, installation speed and a low investment cost per kW, this air conditioner is the ideal solution for hyperscale and colocation datacentres

## High Density Applications

In IT cooling applications where the cooling required per rack exceeds 15kW, the risk of hot spots demand a more targeted cooling solution.

### ■ Mitsubishi Electric's range of close coupled air conditioning solutions

Utilising the latest generation of cooling technologies to prevent the risk of hot spots in the data centre, the goal of close coupled air conditioning is to bring the cooling technology as near to the heat source as possible: the computer rack.

By moving the air conditioner closer to the computer rack, a more precise delivery of inlet air and a more immediate capture of exhaust air is possible, ensuring the most demanding IT systems are kept at optimal conditions, reducing the risk of outages, while maintaining optimal efficiency.



## Multi Density with Variable Refrigerant Flow [VRF]

Bringing together Mitsubishi Electric's leading VRF Technology with close coupled precision cooling.

Mitsubishi Electric's new Multi Density systems combine the efficiency, quality and simplicity of City Multi VRF, with high performance close coupled cooling solutions for high density data rooms.

Plug and play

Long pipe runs

High efficiency

Proven technology

### Mitsubishi Electric cooling only VRF outdoor units

Multi Density is ideal for applications where high sensible cooling and close control of temperature in high density applications is required. Multi Density takes advantage of more than 50 years' experience of the RC brand within the IT cooling market, coupled with Mitsubishi Electric renowned quality standards.

This indoor cooling package consists of multiple Coolside close coupled air conditioners, connected to a City Multi VRF outdoor unit. The result is a full inverter multi-split system, designed according to the best quality standards and dedicated to the most reliable IT environments.

Wide operating range

Self-developed inverter compressor technology

M-Net control

Mitsubishi Electric Quality, manufactured in Japan



CITY MULTI

### Coolside close coupled In-row cooling solutions

These systems are suitable for application in modern IT infrastructure that is typically characterised by high thermal loads, and are particularly suitable for high density racks and blade server cooling in data centres with hot-spots.

The range is able to cope with the high density of the thermal load, with minimal impact of space in the data centre. In-row technology puts the air conditioning unit directly within the rows of racks to cool the localised heat sources.



## Multi Density Features & Benefits

### ■ Up to 8 close coupled indoor units connected to one VRF outdoor unit

High density hot spots are cooled by multiple indoor units connected to a VRF outdoor unit, working together as a unique system.

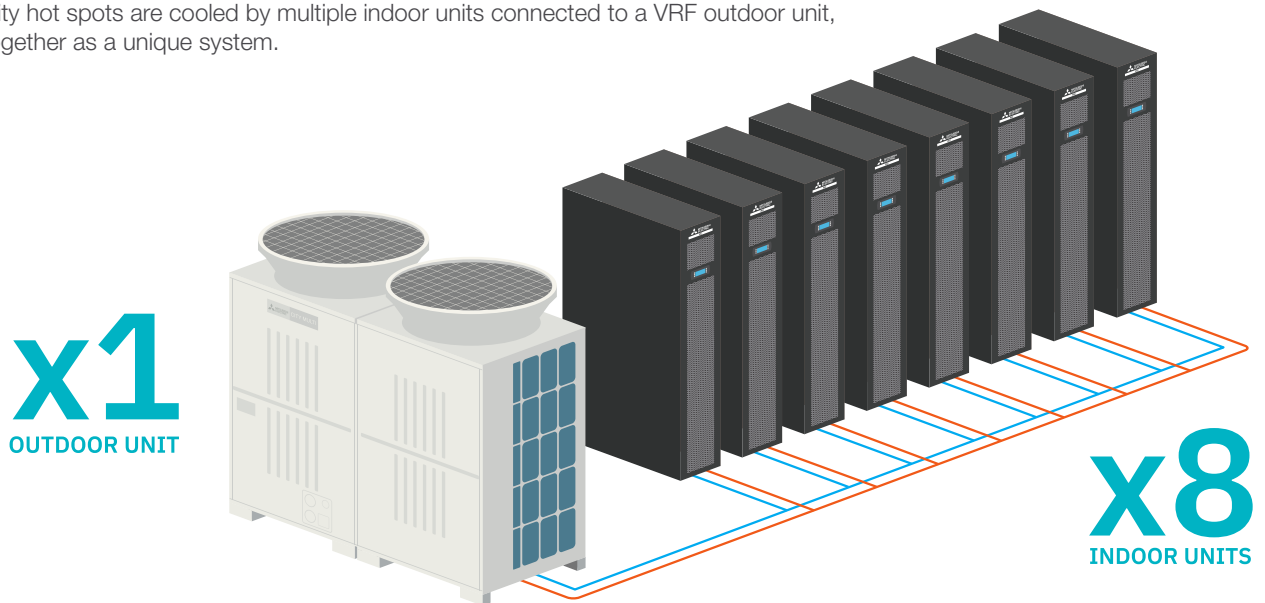

### ■ Compact footprint

By minimising the number of outdoor units, the overall footprint of the system is reduced.

### ■ System reliability

Multi Density is configurable to provide customers with their desired level of reliability (configuration N, N+1, 2N).

The Multi Density system is in line with TIER III and IV design topologies, based on the configuration selected.

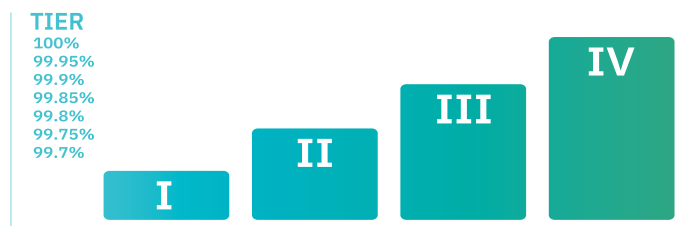

### ■ Application flexibility

Match any kind of cooling requirement, from localised cooling, to hot and cold aisle cooling management.

### ■ Plug and play installation

No additional elements such as pumps, tanks or valves are required. This helps to reduce installation time and costs, and minimise future maintenance requirements.



### ■ Active redundancy

The Active Redundancy function ensures that heat loads are balanced amongst the units (including those units in stand-by) according to the actual system requirements of the IT infrastructure. Multi Density is perfectly set-up for this, due to its multi unit configuration.





## The modular approach of Multi Density Systems

Close coupled In-row units are connected in a primary-secondary configuration. If the primary unit becomes disconnected, 'Dynamic Primary' logic automatically elects a new primary from the remaining units and the system will continue to operate effectively.

Thanks to the flexible and modular approach of the Multi Density system, selection of the ideal solution for a data centre, based on the level of redundancy required, is easily achievable.

### Configuration without redundancy (N)

#### Ideal for small to medium sized IT applications

- 1 outdoor unit paired with up to 5 indoor units
- Average system EER is approx. 3.00
- Cooling capacity up to 50kW

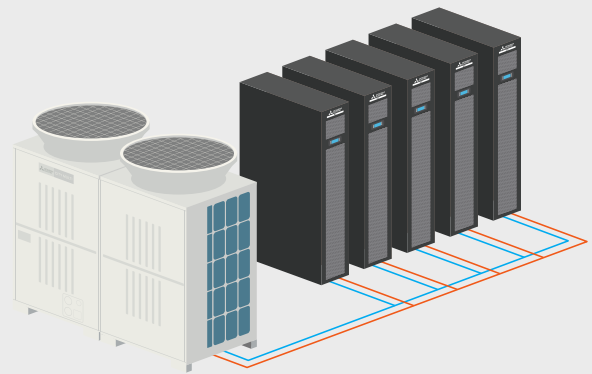

### Configuration with redundancy (N+1)

#### Ideal for TIER II IT applications

- 2 outdoor units paired with up to 8 indoor units
- The external units operate load sharing at partial loads for higher efficiency
- In case of failure of one of the outdoor units, the second one operates at full load
- Average system EER approx. 3.25
- Cooling capacity up to 50kW

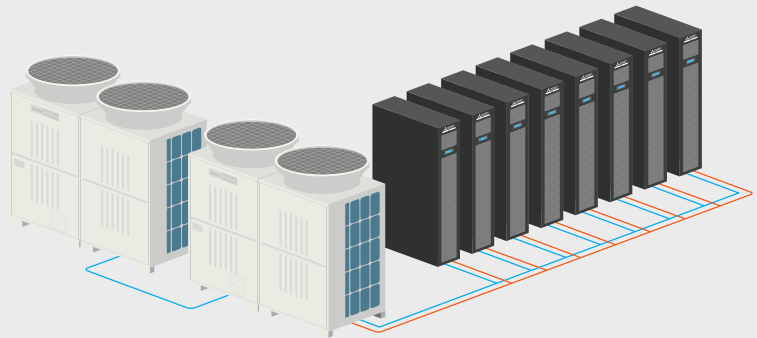

### Configuration 2N

#### Ideal for TIER III and TIER IV data centres

In accordance with the Uptime Institute's classification, this configuration offers:

- A fully redundant and mirrored system with two independent distribution systems
- 1+1 outdoor units paired with 5+5 indoor units

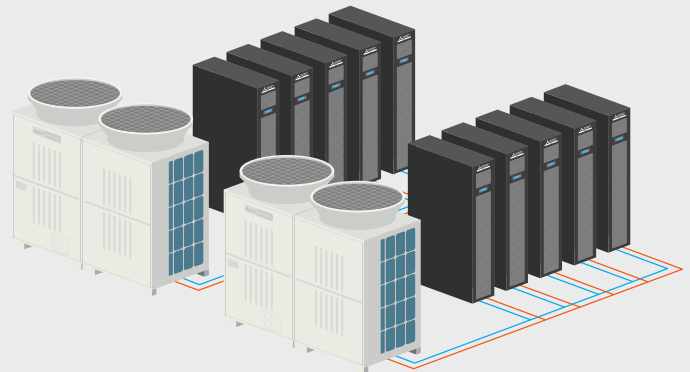

# High Density Coolside Range

The Coolside range of close coupled air conditioning systems provides highly efficient targeted cooling, low operating costs and a flexible layout.

Modulation of airflow is possible due to the incorporation of EC high efficiency fans:



- EC fans adapt to the thermal load detected by sensors positioned in the hot and cold aisles
- New generation EC brushless fans made of ultralight material
- Noise level reduction of 4-5 dB(A) compared to standard fans
- Absorbed power reduction of 15% compared to standard fans
- ‘Hot Swappable’ EC fans can be accessed from the front

## ■ Active free cooling

High density Coolside solutions (single or dual circuit) allow a water circuit to harness the free cooling potential. In the Coolside Dual Circuit version, while the primary circuit (circuit 1) could be water cooled via an external dry cooler in order to maximise the free cooling benefits, the secondary backup circuit (circuit 2) can be easily combined with a free cooling chiller, for perfect redundancy and unbeatable efficiency.

## ■ Direct expansion or chilled water versions available

Perfectly compatible with most racks and ready for future expansion of the cooling system.

### Coolside DX: Direct Expansion

- DC inverter compressor
- New generation EC brushless fans
- **Capacity from 4.7 to 68.3kW**

### Coolside CW: Chilled Water

- New generation EC brushless fans
- 3-way modulating valve
- **Capacity from 16 to 74.7kW**

### Coolside DF: Dual Fluid

- DC inverter compressor
- Double coil
- **Capacity from 4.5 to 16.7kW**



### Coolside FC: Free Cooling

- DC inverter compressor
- New-generation EC brushless fans
- **Capacity from 4.6 to 17.5kW**
- 60% of the year in free cooling

### Coolside Row DX: Direct Expansion with Integrated Compressor

- Installation within the row; does not require underfloor plenum, ducts or false-ceilings
- DC inverter compressor integrated within the air conditioner
- **Capacity from 14 to 39kW**



# Coolside Configurations

From large to small IT environments, Coolside solutions are available in both 'In-row' and 'Enclosure' configurations, providing a range of adaptable data centre solutions.

## In-row air delivery options

Ideal for hot and cold aisles, the 'In-row' configuration draws the air from the hot aisle of the data centre (35°C) through the rear of the unit. The air is then cooled and delivered to the cold aisle (18-20°C) from the front of the rack.



Left-side frontal air delivery.  
Rear air suction.



Frontal air delivery from both sides.  
Rear air suction.



Right-side frontal air delivery.  
Rear air suction.



Frontal air delivery.  
Rear air suction.

## Enclosure

Ideal for removing hot spots in stand-alone systems, the 'Enclosure' configuration is where both the servers and the air conditioners are coupled on the same structure, avoiding the mixing of air streams and creating a clean environment within the rack. The air is directly treated inside the rack; entering at 46°C, cooled down to 25-30°C and then delivered back to the servers. This increases energy saving thanks to the low quantities of treated air.



Right-side frontal air delivery.  
Right-side air suction from the rear.



Left-side frontal air delivery.  
Left-side air suction from the rear.



Frontal air delivery from both sides.  
Rear air suction from both sides.

# Coolside Door System

The Coolside Door unit is an innovative and efficient system for managing hot spots inside data centres, where very high density racks are present.

The Coolside Door unit is housed at the rear of the rack and is managed by a dynamic system, especially designed to handle the rack exhaust air, while intelligent controls adapt to the rack requirements.

The Coolside Door unit can be considered both as a stand-alone cooling unit for the exhaust air of a single rack in small data centres, or as a system for managing hot spots in large data centres to support the function of hot and cold aisles or aisle containment structures.

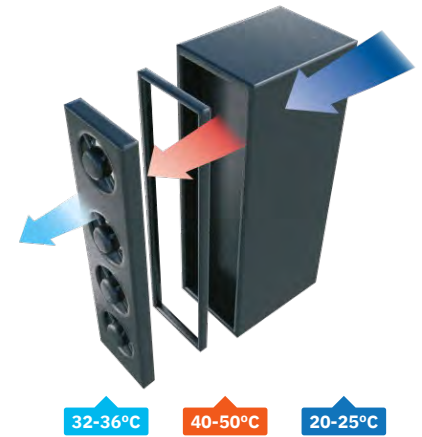

**Chilled water coils** available in both single and double circuits

**Zero footprint**

**Adaptable for almost all racks**

**High energy efficiency** with electronically controlled fans modulated to specific needs

**Dynamic air stratification management** of the rack temperatures thanks to eight independent sensors

**Flexible connections** from the top and from the bottom, depending on choice and on raised floor availability





# Free Cooling Technology - the ultimate solution to harness the full potential of outdoor air

In British climates, data centre managers can reduce the OPEX (operating expenditure) of their IT cooling plant by taking advantage of favourable environmental conditions, when the outdoor air is cooler than the operating water temperature serving the air conditioning units.

For example, in a data centre with an operating water temperature of 28/20°C (In/Out), a free cooling chiller from RC can satisfy the whole cooling demand for 50% of the time utilising free cooling. For the majority of the remainder of the time, the demand is then satisfied by running the compressors at part loads, alongside free cooling. This means that 99.9% of the time the chiller will be operating with free cooling activated, and will spend minimal time in pure 'mechanical' mode.

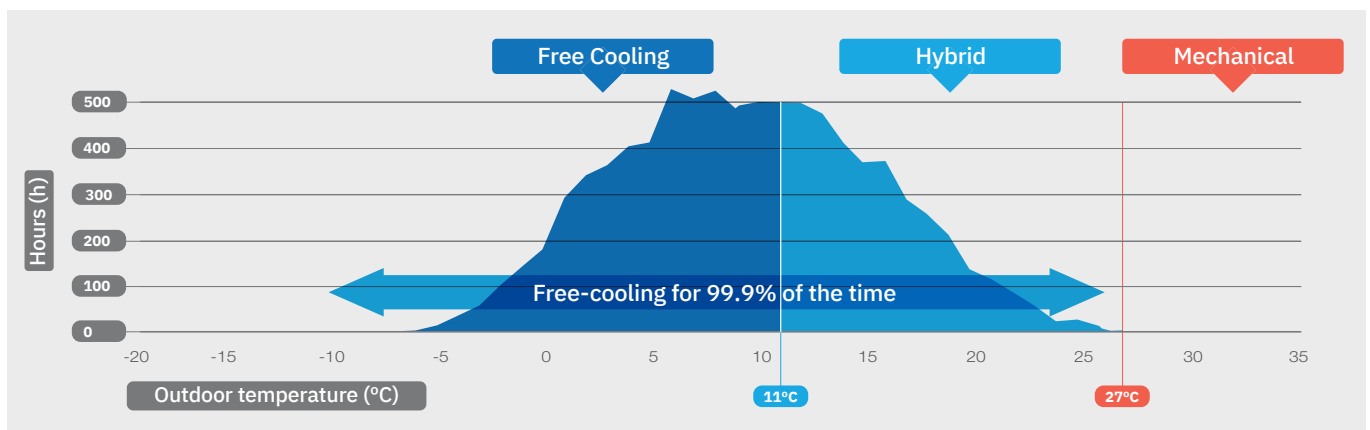

## The higher the water operating temperature - the greater the annual free cooling potential

The energy saving as a result of the use of free cooling is dependent on the water temperature required to operate the air conditioning units within the data centre. Raising the operating water temperature, allows the use of free cooling for larger proportions of the year. Comparing the efficiency of a free cooling chiller and a traditional scroll compressor chiller, the large efficiency gap in the free cooling temperature range is evident. In any modern IT infrastructure, free cooling technology is a crucial technology to reduce OPEX and energy usage.

## In total free cooling, the compressors are off and minimum energy is needed to satisfy the nominal cooling capacity

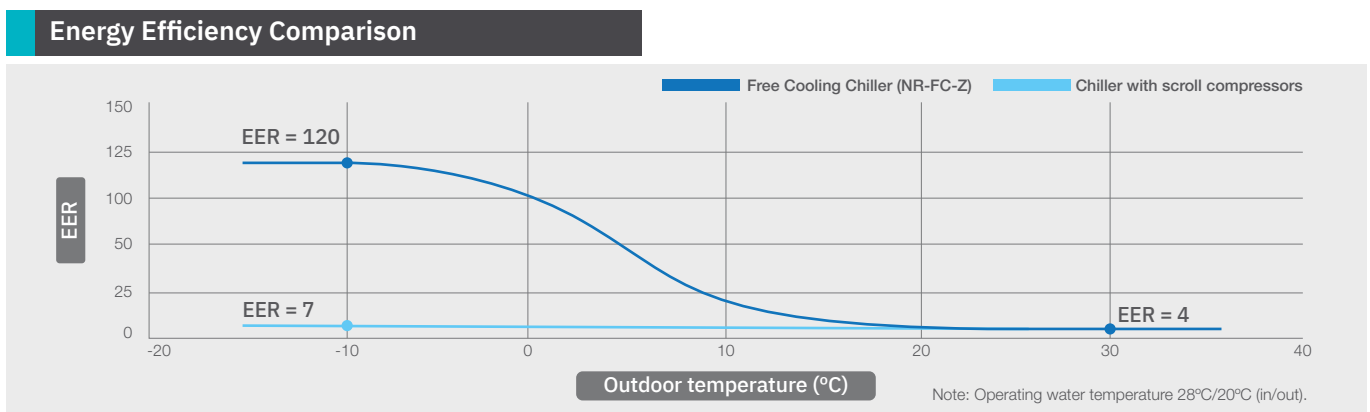



# NR2-FC-G06-Z

Free Cooling Chiller dedicated to high temperature IT environments



**Air cooled chiller** with scroll compressors and free cooling technology from 364 to 978kW

Specifically designed to operate with high water temperatures (supply set-point up to 24°C) and a high Delta T (up to 11°C), the NR2-FC-G06-Z delivers substantial energy savings in modern data centres. The free cooling hydraulic equipment allows the unit to utilise outside air to meet the cooling capacity.

When the air temperature is too high to allow complete free cooling, highly efficient scroll compressors ensure full load coverage. Smart LAN functions also allow simple plug and play connection of multiple NR2-FC-G06-Z chillers and enhance the system's efficiency and stability.



## Smart LAN Logic

Embedded functions for multi-unit systems

### Group controls

Up to 16 chillers can be connected and run as a group to enhance the system's efficiency and dependability.

- Dynamic primary
- Stand-by unit management
- Load sharing or sequencing
- Resource priority management
- Group fast restart
- Centralised pump control

### Adaptive set-point

The indoor chilled water units communicate their load conditions to the external group of chillers, adjusting their operating set-point accordingly, maximising energy savings.

## Total Free Cooling from 11°C

Thanks to large free cooling coils, the NR2-FC-G06-Z uses the outdoor air as its main source to produce cooling. **With a set-point of 20°C, the total free cooling operation is possible from outdoor air temperatures of 11°C.** This means that most of the time the chiller can provide the required cooling capacity without using the compressor.

**The highest standards of reliability and reduced running costs, without any compromises.**



# i-FR-G05-Z

Air Cooled Inverter Chiller



**Air cooled chiller** with inverter screw compressors for outdoor installation from 477 to 1697kW

Thanks to the variable speed technology applied on both the compressors and fans, the i-FR-G05-Z ensures top-level energy efficiency values and complete dependability.

Optimised to work with high temperature IT environments, the chiller's outstanding performance brings significant PUE (Power Usage Effectiveness) reduction and helps to keep the OPEX under control.



## Leading Inverter Technology

The new i-FR-G05-Z showcases the latest variable speed technology:

- Dual screw compressors with integrated refrigerant cooled inverter motor and smart variable Vi Logic
- High efficiency variable speed fans
- Optional variable speed hydronic modules

## Smart Variable Vi Logic

### Variable speed drive

An integrated and compact frequency converter (refrigerant cooled) for outstanding seasonal efficiency and wide capacity regulation.

### Automatic internal volume ratio adaption

An integrated Vi slider adapts the internal geometry to the current operating condition, thus ensuring the best efficiency.

### Extra durability achieved via dedicated components:

- Envelope control function, 3-stage warning and alarm system, safe-torque-off function
- Carbon steel bearings granted for a lifetime of over 150,000 hours

### High efficiency high speed motor

For unprecedented full and part load efficiencies and extremely wide and accurate capacity regulation.

## High Degree of Configurability

A bespoke list of options, such as integrated hydronic modules, allows the i-FR-G05-Z to be configurable for multiple applications.

## Extended Operating Range

Wide operating range, working with outdoor air temperatures from -20°C up to +55°C, thanks to specifically developed options and smart control logic.

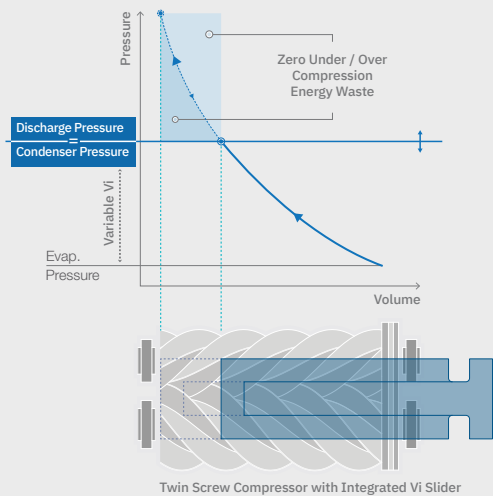



# TR2-FC-G04-Z

High Efficiency Air Cooled  
Free Cooling Chiller



**High efficiency air cooled chiller** with oil-free compressors and free cooling from 302-1693kW

Strict energy consumption and environmental impact regulations continually drive for more efficient air conditioning. Achieving the greatest energy savings and ensuring long-term sustainability are challenges that modern cooling systems need to address.



## Key Features

- Oil Free magnetic levitating centrifugal compressors
- Low GWP HFO Refrigerant
- EC Fans
- Extended use of free cooling
- Optimised for high water temperatures 32°C / 20°C

The TR2-FC-G04-Z range of chillers adopts highly efficient oil-free centrifugal technology with an advanced free cooling system that has been conceived to reduce the compressor operation and maximise the use of the outdoor air.

This leading compressor technology brings benefits in terms of efficiency, adjustments, vibrations and weight. Magnetic levitation eliminates the need for lubricant, through precise management of the levitating drive shaft. Partial load efficiency, which is crucial during the hybrid operation, is therefore dramatically increased.

This product utilises the RC brand's knowledge and experience in oil-free compressor unit development, across multiple of projects all over the world.



A large wall of digital displays in a control room, showing various data visualizations and charts. The displays are arranged in a grid and feature colorful data points, lines, and text. The overall scene is dimly lit, with the primary light source being the screens themselves. The perspective is from a low angle, looking up at the wall of screens.

# Specifications



# MSY-TP

## High SHF Wall Mounted System - Inverter Heat Pump (Cooling Only)

The M Series MSY-TP High SHF wall mounted system blends energy efficiency with a modern white design. This cooling only unit has a high sensible cooling capacity, making it ideal for small computer rooms or areas that require a greater degree of sensible cooling. The MSY-TP also utilises lower GWP R32 refrigerant.

### Key Features

- Compact and stylish white design
- High sensible cooling ability
- Weekly timer provides greater control of scheduling
- Cooling down to -25°C outdoor air temperature



MSY-TP - INDOOR UNITS				
MODEL			MSY-TP35VF	MSY-TP50VF
CAPACITY (kW)	Cooling (nominal)		3.5 (1.5-4.0)	5.0 (1.5-5.7)
	Cooling (UK)		3.47 (1.48-3.96)	4.96 (1.48-5.65)
SHF (nominal)			0.98	0.82
EER (nominal)			4.61	3.45
SEER (BS EN14825)			9.00	8.00
ErP ENERGY EFFICIENCY CLASS	Cooling		A+++	A++
AIRFLOW (l/s)	Cooling - Lo-Mi-Hi-SHi		168-193-228-273	168-193-228-273
PIPE SIZE mm (in)	Gas		9.52 (3/8")	9.52 (3/8")
	Liquid		6.35 (1/4")	6.35 (1/4")
SOUND PRESSURE LEVEL (dBA)	Cooling - Lo-Mi-Hi-SHi		31-36-40-45	31-36-40-45
SOUND POWER LEVEL (dBA)			60	60
DIMENSIONS (mm)	Width x Depth x Height		923 x 250 x 305	923 x 250 x 305
WEIGHT (kg)			12.5	12.5
ELECTRICAL SUPPLY			220-240v, 50Hz	220-240v, 50Hz
FUSE RATING (BS88) – HRC (A)			10	10
INTERCONNECTING CABLE No. CORES			4	4

MUY-TP - OUTDOOR UNITS				
MODEL			MUY-TP35VF	MUY-TP50VF
SOUND PRESSURE LEVEL (dBA)	Cooling		45	47
SOUND POWER LEVEL (dBA)	Cooling		58	61
WEIGHT (kg)			34	34
DIMENSIONS (mm)	Width x Depth x Height		800 x 285 x 550	800 x 285 x 550
ELECTRICAL SUPPLY			Fed by Indoor Unit	Fed by Indoor Unit
PHASE			Single	Single
SYSTEM POWER INPUT (kW)	Cooling (nominal)		0.76	1.45
	Cooling (UK)		0.64	1.12
STARTING CURRENT (A)			3.6	6.4
SYSTEM RUNNING CURRENT (A)	Cooling [MAX]		3.6 [9.2]	6.4 [9.2]
FUSE RATING (BS88) – HRC (A)			10	10
MAINS CABLE No. CORES			3	3
MAX Pipe LENGTH (m)			20	20
MAX HEIGHT DIFFERENCE (m)			12	12
CHARGE REFRIGERANT (kg) / CO <sub>2</sub> EQUIVALENT (t) - R32 (GWP 675)			0.85 / 0.57	0.85 / 0.57
MAX ADDITIONAL REFRIGERANT (kg) / CO <sub>2</sub> EQUIVALENT (t) - R32 (GWP 675)			0.13 / 0.09	0.13 / 0.09

**Notes:** The SHF figures are based on nominal conditions.  
Requires an additional MAC-334IF-E interface and PAR-40MAA wired remote controller.

## s-MEXT-G00 DX

### R32 Close Control System

High precision air conditioners are ideal for applications where high sensible cooling and close control of temperature and humidity are required.

s-MEXT takes advantage of more than 50 years experience of the RC brand within the IT cooling market, coupled with Mitsubishi Electric renowned quality standards. The split cooling package consists of the indoor s-MEXT air conditioner connected to a Mr Slim R32 Power Inverter outdoor unit. The result is a full inverter split system, designed according to the best quality standards and dedicated to the most reliable IT environments.



#### Key Features

- High Efficiency - full Mitsubishi Electric inverter technology and EC plug fans
- Small footprint
- Trusted Mr Slim Power Inverter technology
- Pipe runs up to 100m
- Available in Upflow [over] and Downflow [under] variants



CRAC UNITS (Computer Room Air Conditioner)			s-MEXT-G00-DX -F1-006-S	s-MEXT-G00-DX -F1-009-S	s-MEXT-G00-DX -F1-013-S	s-MEXT-G00-DX -F1-022-S	s-MEXT-G00-DX -F1-038-S	s-MEXT-G00-DX -F1-044-S
<b>PERFORMANCE</b>								
COOLING CAPACITY *1	Total	kW	6.81	10.1	11.9	22.5	38.9	42.3
	Sensible	kW	6.08	8.88	10.2	19.3	33.6	35.2
SHR *2			0.89	0.88	0.86	0.86	0.86	0.83
EER			4.67	4.3	3.49	3.16	3.56	2.866
<b>REFRIGERANT</b>								
REFRIGERANT	Type		R32	R32	R32	R32	R32	R32
REFRIGERANT CIRCUITS	No.		1	1	1	1	2	2
<b>CONNECTIONS</b>								
REFRIGERANT PIPES DIAMETER - GAS	Ø Inch		5/8"	5/8"	5/8"	1"	1"	1"
REFRIGERANT PIPES DIAMETER - LIQUID	Ø Inch		3/8"	3/8"	3/8"	1/2"	3/8"	1/2"
CONDENSATE *5	Ø mm		19	19	19	19	19	19
POWER SUPPLY WIRING CABLE *6	No. x mm <sup>2</sup>		3G1.5	3G1.5	3G1.5	3G1.5	5G1.5	5G1.5
<b>FANS</b>								
FAN TYPE			EC BASIC	EC BASIC	EC BASIC	EC BASIC	EC BASIC	EC BASIC
EC SUPPLY FAN	No.		1	1	1	2	1	1
AIRFLOW	m <sup>3</sup> /h		2000	2500	2800	5000	8800	10000
NOMINAL EXTERNAL STATIC PRESSURE	Pa		20	20	20	20	20	20
POWR INPUT *3	kW		0.21	0.35	0.47	0.7	1.43	1.96
<b>ELECTRICAL HEATER</b>								
QUANTITY	No.		1	1	1	1	1	1
STEPS	No.		2	2	2	3	3	3
ELECTRICAL POWER ABS.	kW		2.6	2.6	2.6	3.9	9	9
MAX ABSORBED CURRENT	A		11.3	11.3	11.3	17	13	13
POWER SUPPLY	V/ph/Hz		230/1/50	230/1/50	230/1/50	230/1/50	400/3/50	400/3/50
<b>HUMIDIFIER</b>								
QUANTITY	No.		1	1	1	1	1	1
CAPACITY	kg/h		3	3	3	3	8	8
ELECTRICAL POWER ABS.	kW		2.3	2.3	2.3	2.3	6	6
MAX ABSORBED CURRENT	A		14.1	14.1	14.1	14.1	12.4	12.4
POWER SUPPLY	V/ph/Hz		230/1/50	230/1/50	230/1/50	230/1/50	400/3/50	400/3/50
<b>SOUND LEVEL [ISO 3744] *4</b>								
PRESSURE LEVEL	dB(A)		53	57	61	60	63	67
POWER LEVEL	dB(A)		69	73	77	76	79	83
<b>ELECTRICAL DATA</b>								
POWER SUPPLY	V/ph/Hz		230/1/50	230/1/50	230/1/50	230/1/50	400/3/50	400/3/50
STARTING CURRENT	A		2	2	2.8	3.3	3.8	3.8
MAX ABSORBED CURRENT	A		27.7	27.7	28.2	35	29.2	29.2
<b>DIMENSIONS AND WEIGHT</b>								
DIMENSIONS	Width x Depth x Height	mm	600 x 500 x 1980	600 x 500 x 1980	600 x 500 x 1980	1000 x 500 x 1980	1000 x 890 x 1980	1000 x 890 x 1980
NET WEIGHT	Upflow (O)	kg	107	110	114	169	247	247
	Downflow (U)	kg	114	119	124	179	257	257

OUTDOOR UNITS		PUZ-ZM60VHA2	PUZ-ZM100VKA2	PUZ-ZM125YKA2	PUZ-ZM250YKA2	2x PUZ-ZM200YKA2	2 x PUZ-ZM250YKA2
SOUND PRESSURE LEVEL (dB(A))	Cooling	47	49	50	59	59	59
WEIGHT (kg)		70	116	125	138	137	138
DIMENSIONS (mm)	Width x Depth x Height	950 x 330 + 25 x 943	1050 x 330 + 40 x 1338	1050 x 330 + 40 x 1338	1050 x 330+40 x 1338	1050 x 330+40 x 1338	1050 x 330+40 x 1338
ELECTRICAL SUPPLY		220-240v, 50Hz	220-240v, 50Hz	380-415v, 50Hz	380-415v, 50Hz	380-415v, 50Hz	380-415v, 50Hz
PHASE		Single	Single	Three	Three	Three	Three
OUTDOOR POWER INPUT (kW)	Cooling (nominal)	1.25	2.00	2.94	6.41	4.73	6.41
STARTING CURRENT (A)		5.0	5.0	5.0	5.0	5.0	5.0
MAX RUNNING CURRENT (A)	Cooling	19.2	27.0	10.0	22.5	22.5	22.5
FUSE RATING (BS88) - HRC (A)		25	32	16	32	32	32
MAINS CABLE	No. Cores	3	3	5	5	5	5
MAX PIPE LENGTH (m)		55	100	100	100	100	100
MAX HEIGHT DIFFERENCE (m)		30	30	30	30	30	30
CHARGE REFRIGERANT (kg) / CO <sub>2</sub> EQUIVALENT (t)	R32 (GWP 675) - 30m	2.80 / 1.89	4.00 / 2.70	4.00 / 2.70	6.80 / 4.59	6.30 / 4.25	6.80 / 4.59
MAX ADDITIONAL REFRIGERANT (kg) / CO <sub>2</sub> EQUIVALENT (t)	R32 (GWP 675)	0.80 / 0.54	2.80 / 1.89	2.80 / 1.89	2.40 / 1.62 (70m) <sup>7</sup>	1.60 / 1.08 (70m) <sup>7</sup>	2.40 / 1.62 (70m) <sup>7</sup>
GUARANTEED OPERATING RANGE (°C)	Max Temp	46	46	46	46	46	46
	Min Temp <sup>8</sup>	-15	-15	-15	-15	-15	-15

**Notes:** The cooling capacity does not consider the supply fan motor thermal load. \*1 Gross value based on return air of 27°C - 47%RH; Ambient Temperature 35°C; ESP=20Pa; Interconnecting pipework length 5m. \*2 SHR = Sensible cooling capacity / Total cooling capacity. \*3 Corresponding to the nominal ESP=20Pa. \*4 Sound pressure level on air return at 1m. \*5 Rubber pipe - referred to internal diameter. \*6 Minimum section. \*7 For 70 to 100m please consult the service handbook. \*8 Optional air protection guide is required for temperatures below -5°C. These units contain <HFC R32 (GWP100 675)> fluorinated greenhouse gas.

## s-MEXT-G00 DX

### R410A Close Control System



High precision air conditioners are ideal for applications where high sensible cooling and close control of temperature and humidity are required.

s-MEXT takes advantage of more than 50 years experience of the RC brand within the IT cooling market, coupled with Mitsubishi Electric renowned quality standards. The split cooling package consists of the indoor s-MEXT air conditioner connected to a Mr Slim R410A Power Inverter outdoor unit. The result is a full inverter split system, designed according to the best quality standards and dedicated to the most reliable IT environments.

#### Key Features

- High Efficiency - full Mitsubishi Electric inverter technology and EC plug fans
- Small footprint
- Trusted Mr Slim Power Inverter technology
- Pipe runs up to 100m
- Available in Upflow [over] and Downflow [under] variants



CRAC UNITS (Computer Room Air Conditioner)			s-MEXT-G00-DX -F1-006-S	s-MEXT-G00-DX -F1-009-S	s-MEXT-G00-DX -F1-013-S	s-MEXT-G00-DX -F1-022-S	s-MEXT-G00-DX -F1-038-S	s-MEXT-G00-DX -F1-044-S
<b>PERFORMANCE</b>								
COOLING CAPACITY *1	Total	kW	6.78	10.1	11.9	22.4	38.7	42.2
	Sensible	kW	6.18	8.89	10.3	19.5	34	37.4
SHR *2			0.91	0.89	0.87	0.87	0.88	0.89
EER			3.88	4.01	3.01	2.87	3.14	2.61
<b>REFRIGERANT</b>								
REFRIGERANT	Type		R410A	R410A	R410A	R410A	R410A	R410A
REFRIGERANT CIRCUITS	No.		1	1	1	1	2	2
<b>CONNECTIONS</b>								
REFRIGERANT PIPES DIAMETER - GAS	Ø Inch		5/8"	5/8"	5/8"	1"	1"	1"
REFRIGERANT PIPES DIAMETER - LIQUID	Ø Inch		3/8"	3/8"	3/8"	1/2"	3/8"	1/2"
CONDENSATE *5	Ø mm		19	19	19	19	19	19
POWER SUPPLY WIRING CABLE *6	No. x mm <sup>2</sup>		3G1.5	3G1.5	3G1.5	3G1.5	5G1.5	5G1.5
<b>FANS</b>								
FAN TYPE			EC BASIC	EC BASIC	EC BASIC	EC BASIC	EC BASIC	EC BASIC
EC SUPPLY FAN	No.		1	1	1	2	1	1
AIRFLOW	m <sup>3</sup> /h		2000	2500	2800	5000	8800	10000
NOMINAL EXTERNAL STATIC PRESSURE	Pa		20	20	20	20	20	20
POWR INPUT *3	kW		0.21	0.35	0.47	0.7	1.43	1.96
<b>ELECTRICAL HEATER</b>								
QUANTITY	No.		1	1	1	1	1	1
STEPS	No.		2	2	2	3	3	3
ELECTRICAL POWER ABS.	kW		2.6	2.6	2.6	3.9	9	9
MAX ABSORBED CURRENT	A		11.3	11.3	11.3	17	13	13
POWER SUPPLY	V/ph/Hz		230/1/50	230/1/50	230/1/50	230/1/50	400/3/50	400/3/50
<b>HUMIDIFIER</b>								
QUANTITY	No.		1	1	1	1	1	1
CAPACITY	kg/h		3	3	3	3	8	8
ELECTRICAL POWER ABS.	kW		2.3	2.3	2.3	2.3	6	6
MAX ABSORBED CURRENT	A		14.1	14.1	14.1	14.1	12.4	12.4
POWER SUPPLY	V/ph/Hz		230/1/50	230/1/50	230/1/50	230/1/50	400/3/50	400/3/50
<b>SOUND LEVEL [ISO 3744] *4</b>								
PRESSURE LEVEL	dB(A)		53	57	61	60	63	67
POWER LEVEL	dB(A)		69	73	77	76	79	83
<b>ELECTRICAL DATA</b>								
POWER SUPPLY	V/ph/Hz		230/1/50	230/1/50	230/1/50	230/1/50	400/3/50	400/3/50
STARTING CURRENT	A		2	2	2.8	3.3	3.8	3.8
MAX ABSORBED CURRENT	A		27.7	27.7	28.2	35	29.2	29.2
<b>DIMENSIONS AND WEIGHT</b>								
DIMENSIONS	Width x Depth x Height	mm	600 x 500 x 1980	600 x 500 x 1980	600 x 500 x 1980	1000 x 500 x 1980	1000 x 890 x 1980	1000 x 890 x 1980
NET WEIGHT	Upflow (O)	kg	107	110	114	169	247	247
	Downflow (U)	kg	114	119	124	179	257	257

OUTDOOR UNITS		PUHZ-ZRP60VHA2	PUHZ-ZRP100VKA3	PUHZ-ZRP125YKA3	PUHZ-ZRP250YKA3	2x PUHZ-ZRP200YKA3	2 x PUHZ-ZRP250YKA3
SOUND PRESSURE LEVEL (dB(A))	Cooling	47	49	50	59	59	59
WEIGHT (kg)		70	116	125	135	135	135
DIMENSIONS (mm)	Width x Depth x Height	950 x 330 x 943	1050 x 330 + 40 x 1338	1050 x 330 + 40 x 1338	1050 x 330 + 40 x 1338	1050 x 330 + 40 x 1338	1050 x 330 + 40 x 1338
ELECTRICAL SUPPLY		220-240v, 50Hz	220-240v, 50Hz	380-415v, 50Hz	380-415v, 50Hz	380-415v, 50Hz	380-415v, 50Hz
PHASE		Single	Single	Three	Three	Three	Three
OUTDOOR POWER INPUT (kW)	Cooling (nominal)	1.53	2.17	3.49	7.11	5.44	7.11
STARTING CURRENT (A)		5	12	4	5	5	5
MAX RUNNING CURRENT (A)	Cooling	19	26.5	9.45	21	19	21
FUSE RATING (BS88) - HRC (A)		25	32	16	32	32	32
MAINS CABLE	No. Cores	3	3	5	5	5	5
MAX PIPE LENGTH (m)		50	75	75	100	100	100
MAX HEIGHT DIFFERENCE (m)		30	30	30	30	30	30
CHARGE REFRIGERANT (kg) / CO <sub>2</sub> EQUIVALENT (t)	R410A (GWP 2088) - 30m	3.50 / 7.31	5.00 / 10.44	5.00 / 10.44	7.70 / 16.08	7.10 / 14.82	7.70 / 16.08
MAX ADDITIONAL REFRIGERANT (kg) / CO <sub>2</sub> EQUIVALENT (t)	R410A (GWP 2088)	1.20 / 2.51	2.40 / 5.01	2.40 / 5.01	4.80 / 10.02 (75m) <sup>7</sup>	3.60 / 7.52 (75m) <sup>7</sup>	4.80 / 10.02 (75m) <sup>7</sup>
GUARANTEED OPERATING RANGE (°C)	Max Temp	46	46	46	46	46	46
	Min Temp <sup>8</sup>	-15	-15	-15	-15	-15	-15

Notes: The cooling capacity does not consider the supply fan motor thermal load. \*1 Gross value based on return air of 27°C - 47%RH; Ambient Temperature 35°C; ESP=20Pa; Interconnecting pipework length 5m. \*2 SHR = Sensible cooling capacity / Total cooling capacity. \*3 Corresponding to the nominal ESP=20Pa. \*4 Sound pressure level on air return at 1m. \*5 Rubber pipe - referred to internal diameter. \*6 Minimum section. \*7 For 70 to 100m please consult the service handbook. \*8 Optional air protection guide is required for temperatures below -5°C. These units contain <HFC R32 (GWP100 675)> fluorinated greenhouse gas.



## i-NEXT DX

### R410A Close Control System

High precision air conditioners are ideal for applications where high sensible cooling and close control of temperature and humidity is required.

The i-NEXT direct expansion air cooled range incorporates full inverter driven BLDC Mitsubishi Electric compressors and a new microchannel coil remote condenser, perfect for keeping room conditions constant under varying loads, whilst being highly efficient.

#### Key Features

- Perimeter unit available in downflow and upflow configurations
- Full inverter technology with BLDC Mitsubishi Electric compressors
- Ultralight composite EC plug fans resulting in reduced noise and power usage
- Integrated control of up to 10 units for intelligent redundancy management
- Front access to main components for easy inspection and routine maintenance
- Automatic restart from power outage
- Return air temperature operating limits up to 40°C
- New microchannel coil remote condensers with AC axial fans
- Optional Modbus RS485 and BACnet TCP/IP connectivity
- Optional electrical heater and steam humidifiers
- Optional floor stands and discharge plenums



#### CRAC UNITS (Computer Room Air Conditioner)

MODEL		i-NEXT DX 012 M1 S E1	i-NEXT DX 018 M1 S E2	i-NEXT DX 022 M1 S E3	i-NEXT DX 030 M1 S E4	i-NEXT DX 047 M1 S E5	i-NEXT DX 042 M2 D E5	i-NEXT DX 068 M2 D E7	i-NEXT DX 094 M2 D E8	i-NEXT DX 120 M4 D E9 <sup>1</sup>	i-NEXT DX 150 M4 D E9 <sup>1</sup>
COOLING CAPACITY (kW) <sup>2</sup>	Capacity Range	3.2 - 10.0	6.7 - 20.4	7.1 - 23.1	12.5 - 37.7	17.4 - 51.6	15.4 - 47.4	23.9 - 75.7	33.5 - 101.0	25.7 - 108.0	32.1-129.0
	Total	10.0	20.4	23.1	37.7	51.6	47.4	75.7	101.0	108.0	129.0
	Sensible	9.8	19.3	23.1	37.7	51.4	47.4	75.7	97.1	108.0	129.0
SHR <sup>3</sup>	Nominal	0.98	0.95	1.00	1.00	0.99	1.00	1.00	0.96	1.00	1.00
EER <sup>4</sup>	Nominal	3.21	2.80	3.18	3.02	2.98	3.14	3.12	3.01	3.21	2.79
EC SUPPLY FAN(S)	No.	1	1	1	1	1	1	2	2	3	3
AIRFLOW (m <sup>3</sup> /h)		2,800	4,100	5,500	10,000	12,000	12,000	20,000	22,000	28,000	32,000
EXTERNAL STATIC PRESSURE (Pa) Nominal		20	20	20	20	20	20	20	20	20	20
MAX EXTERNAL STATIC PRESSURE (Pa)		75	311	831	191	217	283	451	388	572	379
POWER INPUT (kW)	Fan Motor ESP=20Pa	0.29	0.52	0.78	2.04	2.27	2.05	3.51	3.72	4.20	5.82
	Total <sup>4</sup>	3.11	7.28	7.27	12.50	17.30	15.10	24.30	33.60	33.60	46.30
REFRIGERANT		R410A	R410A	R410A	R410A	R410A	R410A	R410A	R410A	R410A	R410A
REFRIGERANT CIRCUITS	No.	1	1	1	1	1	2	2	2	2	2
COMPRESSORS		BLDC Rotary Inverter	BLDC Scroll Inverter	BLDC Scroll Inverter	BLDC Scroll Inverter	BLDC Scroll Inverter	2x BLDC Scroll Inverter	2x BLDC Scroll Inverter	2x BLDC Scroll Inverter	4x BLDC Scroll <sup>16</sup>	4x BLDC Scroll <sup>16</sup>
AIR FILTERS	No.	1	1	2	2	3	3	4	5	6	6
	Extended filtering surface (m <sup>2</sup> )	0.6	0.8	1.2	2.1	2.6	2.6	3.9	4.5	5.2	5.2
	Efficiency [ISO EN 16890] (COARSE)	60%	60%	60%	60%	60%	60%	60%	60%	60%	60%
SOUND LEVEL dB(A) (ISO3774) <sup>5</sup>	Downflow - Power / Pressure	63 / 47	64 / 48	62 / 46	74 / 57	76 / 59	76 / 59	75 / 58	78 / 60	80 / 62	80 / 62
	Upflow - Power / Pressure	69 / 53	63 / 47	65 / 49	75 / 58	81 / 64	81 / 64	79 / 62	83 / 65	N/A	N/A
POWER SUPPLY (V/Ph/Hz)		400 / 3 / 50+N	400 / 3 / 50+N	400 / 3 / 50+N	400 / 3 / 50+N	400 / 3 / 50+N	400 / 3 / 50+N	400 / 3 / 50+N	400 / 3 / 50+N	400 / 3 / 50+N	400 / 3 / 50+N
STARTING CURRENT (A)		4.3	5.7	8.2	9.2	11.4	8.4	13.9	15.9	70.9	72.9
MAX RUNNING CURRENT (A)		17.3	18.7	21.2	29.2	29.4	38.4	58.9	58.9	90.9	90.9
DIMENSIONS (mm)	Width	650	785	1,085	1305	1630	1630	2175	2499	2899	2899
	Depth	675	675	775	930	930	930	930	930	930	930
	Height	1925	1925	1925	1980	1980	1980	1980	1980	1980	1980
NET WEIGHT (kg)	Downflow	220	250	330	440	490	575	705	865	985	1,010
	Upflow	210	240	320	430	480	565	650	805	N/A	N/A
CONNECTIONS	Refrigerant pipe diameter - Gas (Ø mm) <sup>7</sup>	12	16	16	18	22	2 x 16	2 x 18	2 x 22	2 x 28	2 x 28
	Refrigerant pipe diameter - Liquid (Ø mm) <sup>7</sup>	12	12	16	16	22	2 x 16	2 x 16	2 x 22	2 x 22	2 x 22
	Condensate (Ømm) <sup>8</sup>	19	19	19	19	19	19	19	19	19	19

#### OUTDOOR UNITS / REMOTE CONDENSER(S)

MODEL		GR-Z A B 50 013	GR-Z A B 50 027	GR-Z A B 50 034	GR-Z A B 50 049	GR-Z A B 50 067	2 x GR-Z A B 50 034	2 x GR-Z A B 50 049	2 x GR-Z A B 50 067	2 x GR-Z A B 50 082	2 x GR-Z A B 50 082
AIRFLOW (m <sup>3</sup> /h)		3,300	8,350	9,550	15,555	19,000	9,550	15,555	19,000	25,000	25,000
POWER SUPPLY (V/Ph/Hz)		230 / 1 / 50	230 / 1 / 50	230 / 1 / 50	230 / 1 / 50	230 / 1 / 50	230 / 1 / 50	230 / 1 / 50	230 / 1 / 50	230 / 1 / 50	230 / 1 / 50
MAX POWER INPUT (kW)		0.32	0.64	0.64	1.08	1.28	0.64	1.08	1.28	1.92	1.92
MAX RUNNING CURRENT (A)		1.40	2.90	2.90	4.94	5.80	2.90	4.94	5.80	8.70	8.70
SOUND PRESSURE LEVEL (dB(A)) <sup>5</sup> 1m (ISO3744)		50	55	56	54	58	56	54	58	59	59
DIMENSIONS (mm)	Horizontal Airflow (W x D x H)	770 x 718 x 900	1150 x 718 x 900	1360 x 718 x 1100	2040 x 718 x 1100	2600 x 718 x 1100	1360 x 718 x 1100	2040 x 718 x 1100	2600 x 718 x 1100	2600 x 718 x 1100	2600 x 718 x 1100
	Vertical Airflow (W x L x H)	940 x 770 x 1143	940 x 1150 x 1168	1140 x 1360 x 1168	1140 x 2040 x 1168	1140 x 2600 x 1168	1140 x 1360 x 1168	1140 x 2040 x 1168	1140 x 2600 x 1168	1140 x 2600 x 1168	1140 x 2600 x 1168
NET WEIGHT (kg)		30	45	53	86	100	53	86	100	120	120
CONNECTION SIZE	Refrigerant pipe diameter - Gas (Ø mm) <sup>7</sup>	16	18	18	22	22	18	22	22	28	28
	Refrigerant pipe diameter - Liquid (Ø mm) <sup>7</sup>	12	16	16	18	18	16	18	18	22	22

**Notes:** THE COOLING CAPACITY DOES NOT CONSIDER THE SUPPLY FAN MOTOR THERMAL LOAD. <sup>1</sup> Downflow version only. <sup>2</sup> Gross value based on return air at 26°C - 40%RH; Ambient Temperature 35°C with above condenser(s) models. <sup>3</sup> SHR = Sensible cooling capacity / Total cooling capacity. <sup>4</sup> Compressor(s) & Fan(s) input power (ESP=20Pa) - Remote air cooled condenser not included. <sup>5</sup> Average level at 1m from unit in free field conditions. <sup>6</sup> In 2(1+) configuration, 2 inverter driven with 2 direct online. <sup>7</sup> Please refer to i-NEXT databook for interconnecting pipework size. <sup>8</sup> Rubber pipe - refers to internal diameter. These units contain <HFC R410A [GWP100 2088]> fluorinated greenhouse gas.



## w-MEXT

### Chilled Water Close Control System

High precision air conditioners are ideal for applications where high sensible cooling and close control of temperature and humidity are required.

The w-MEXT chilled water range incorporates the latest EC plug fan(s), advanced controls software and an increased coil area resulting in the highest efficiency.

#### Key Features

- High Efficiency - EC plug fans
- Small footprint
- Adaptive Set Point
- Active Redundancy
- Available in Upflow [over] and Downflow [under] variants
- Integrated control of up to 15 units for intelligent LAN functions



#### CRAH UNITS (Computer Room Air Handler)

MODEL		w-MEXT 006 F1	w-MEXT 009 F1	w-MEXT 011 F1	w-MEXT 013 F1	w-MEXT 016 F2	w-MEXT 022 F2	w-MEXT 026 F2
CAPACITY (kW) <sup>*1,2</sup>	Total	4.74	7.9	9.66	12.5	15.4	20.4	25.6
	Sensible	4.74	7.9	9.66	12.5	15.4	20.4	25.6
SHR <sup>*3</sup>		1.00	1.00	1.00	1.00	1.00	1.00	1.00
EER		67.7	37.6	30.2	27.8	38.5	30.0	26.9
EC SUPPLY FAN(S)	No.	1	1	1	1	2	2	2
ÄIRFLOW (m³/h)		1,500	2,200	2,500	2,700	4,300	5,000	5,400
EXTERNAL STATIC PRESSURE (Pa)		20	20	20	20	20	20	20
MAX EXTERNAL STATIC PRESSURE (Pa)		201	471	384	268	277	362	246
POWER INPUT (kW) <sup>*4</sup>		0.07	0.21	0.32	0.45	0.4	0.68	0.95
ÄIR FILTERS	No.	1	1	1	1	2	2	2
	Extended filtering surface (m²)	0.68	0.68	0.68	0.68	1.05	1.05	1.05
	Efficiency [ISO EN 16890] (COARSE)	60%	60%	60%	60%	60%	60%	60%
CHILLED WATER FLOW RATE (l/s)		0.23	0.38	0.46	0.6	0.74	0.97	1.22
WATERSIDE PRESSURE DROP (kPa)	Coil + 2-Port Valve	37.1	61.1	32.2	55.7	45.6	80.2	108
SOUND LEVEL dB(A) (ISO3774) <sup>*5</sup>	Downflow - Power / Pressure	42 / 58	56 / 72	58 / 74	60 / 76	53 / 69	60 / 76	61 / 78
POWER SUPPLY (V/Ph/Hz)		230 / 1 / 50	230 / 1 / 50	230 / 1 / 50	230 / 1 / 50	230 / 1 / 50	230 / 1 / 50	230 / 1 / 50
MAX RUNNING CURRENT (A)		3.6	4.0	4.0	4.0	7.2	0.8	0.8
DIMENSIONS (mm)	Width	600	600	600	600	1000	1000	1000
	Depth	500	500	500	500	500	500	500
	Height	1980	1980	1980	1980	1980	19680	1980
NET WEIGHT (kg)	Downflow	110	118	126	130	173	183	191
	Upflow	103	109	116	120	163	173	181
CONNECTIONS	Water Inlet / Outlet ISO 7/1 (Ø inch)	3/4"	3/4"	3/4"	1"	1 1/4"	1 1/4"	1 1/4"
	Condensate (Ømm) <sup>*6</sup>	19	19	19	19	19	19	19

**Notes:** THE COOLING CAPACITY DOES NOT CONSIDER THE SUPPLY FAN MOTOR THERMAL LOAD. \*1 Downflow & Upflow version. \*2 Gross value based on return air at 26°C - 40%RH; Chiller water 10°C / 15°C. \*3 SHR = Sensible cooling capacity / Total cooling capacity. \*4 Fan(s) input power (ESP=20Pa). \*5 Average level at 1m from unit in free field conditions. \*6 Rubber pipe - refers to internal diameter.



## w-NEXT

### Chilled Water Close Control System

High precision air conditioners are ideal for applications where high sensible cooling and close control of temperature and humidity are required.

The w-NEXT chilled water range incorporates the latest EC plug fan fan(s), advanced controls software and an increased coil area resulting in the highest efficiency.



#### Key Features

- High Efficiency - EC plug fans
- Small footprint
- Adaptive Set Point
- Active Redundancy
- Available in Upflow [over] and Downflow [under] variants

#### CRAH UNITS (Computer Room Air Handler)

MODEL		w-NEXT S 045 E3P	w-NEXT S 053 E4	w-NEXT S 072 E5
CAPACITY (kW) <sup>*2</sup>	Total	41.0	48.1	66.1
	Sensible	41.0	48.1	66.1
SHR <sup>*3</sup>		1.00	1.00	1.00
EER		18.6	22.4	22.8
EC SUPPLY FAN(S)	No.	1	1	2
AIRFLOW (m <sup>3</sup> /h)		10,800	13,100	16,350
EXTERNAL STATIC PRESSURE (Pa)		20	20	20
MAX EXTERNAL STATIC PRESSURE (Pa)		297	194	532
POWER INPUT (kW) <sup>*4</sup>		2.20	2.15	2.90
AIR FILTERS	No.	2	3	3
	Extended filtering surface (m <sup>2</sup> )	1.71	2.07	2.59
	Efficiency [ISO EN 16890] (COARSE)	60%	60%	60%
CHILLED WATER FLOW RATE (l/s)		1.96	2.30	3.16
WATERSIDE PRESSURE DROP (kPa)	Coil + 2-Port Valve	34.1	37.3	42.9
SOUND LEVEL dB(A) (ISO3774) <sup>*5</sup>	Downflow - Power / Pressure	73 / 57	74 / 57	73 / 56
	Upflow - Power / Pressure	77 / 61	78 / 61	77 / 60
POWER SUPPLY (V/Ph/Hz)		400 / 3+N / 50	400 / 3+N / 50	400 / 3+N / 50
MAX POWER ABSORBED (kW)		2.90	2.70	5.40
MAX RUNNING CURRENT (A)		4.4	4.2	8.4
DIMENSIONS (mm)	Width	1085	1305	1630
	Depth	930	930	930
	Height	1925	1980	1980
NET WEIGHT (kg)	Downflow	321	345	470
	Upflow	329	379	428
CONNECTIONS	Water Inlet / Outlet ISO 7/1 (Ø inch)	1 1/4"	1 1/2"	2"
	Condensate (Ømm) <sup>*6</sup>	19	19	19

#### CRAH UNITS (Computer Room Air Handler)

MODEL		w-NEXT S 081 E6	w-NEXT S 100 E7	w-NEXT S 120 E8	w-NEXT S 138 E9	w-NEXT S 160 E10 <sup>*1</sup>	w-NEXT S 215 E10 <sup>*1</sup>
CAPACITY (kW) <sup>*2</sup>	Total	73.5	91.6	111.0	126.0	147.0	204.0
	Sensible	73.5	91.6	111.0	126.0	147.0	177.0
SHR <sup>*3</sup>		1.00	1.00	1.00	1.00	1.00	0.87
EER		21.2	23.0	17.8	19.6	22.8	31.7
EC SUPPLY FAN(S)	No.	2	2	3	3	3	3
AIRFLOW (m <sup>3</sup> /h)		20,000	24,200	28,300	33,100	37,150	37,150
EXTERNAL STATIC PRESSURE (Pa)		20	20	20	20	20	20
MAX EXTERNAL STATIC PRESSURE (Pa)		458	247	237	309	207	207
POWER INPUT (kW) <sup>*4</sup>		3.47	3.98	6.22	6.42	6.44	6.44
AIR FILTERS	No.	4	4	5	6	6	6
	Extended filtering surface (m <sup>2</sup> )	3.16	3.83	4.47	5.24	6.54	6.54
	Efficiency [ISO EN 16890] (COARSE)	60%	60%	60%	60%	60%	60%
CHILLED WATER FLOW RATE (l/s)		3.51	4.38	5.33	6.04	7.03	9.74
WATERSIDE PRESSURE DROP (kPa)	Coil + 2-Port Valve	35.6	31.7	48.6	47	66.7	62.2
SOUND LEVEL dB(A) (ISO3774) <sup>*5</sup>	Downflow - Power / Pressure	75 / 58	76 / 59	79 / 61	80 / 62	79 / 61	79 / 61
	Upflow - Power / Pressure	79 / 62	80 / 63	83 / 65	81 / 63	N/A	N/A
POWER SUPPLY (V/Ph/Hz)		400 / 3+N / 50	400 / 3+N / 50	400 / 3+N / 50	400 / 3+N / 50	400 / 3+N / 50	400 / 3+N / 50
MAX POWER ABSORBED (kW)		5.80	5.40	8.10	8.70	8.10	8.10
MAX RUNNING CURRENT (A)		8.9	8.3	12.6	13.3	12.5	12.5
DIMENSIONS (mm)	Width	1875	2175	2499	2899	3510	3510
	Depth	930	930	930	930	930	930
	Height	1980	1980	1980	1980	1980	1980
NET WEIGHT (kg)	Downflow	531	589	660	753	900	970
	Upflow	483	535	598	679	N/A	N/A
CONNECTIONS	Water Inlet / Outlet ISO 7/1 (Ø inch)	2"	2 1/2"	2 1/2"	3"	3"	3"
	Condensate (Ømm) <sup>*6</sup>	19	19	19	19	19	19

Notes: THE COOLING CAPACITY DOES NOT CONSIDER THE SUPPLY FAN MOTOR THERMAL LOAD. \*1 Downflow version only. \*2 Gross value based on return air at 24°C - 45%RH; Chiller water 7°C / 12°C. \*3 SHR = Sensible cooling capacity / Total cooling capacity. \*4 Fan(s) input power (ESP=20Pa). \*5 Average level at 1m from unit in free field conditions. \*6 Rubber pipe - refers to internal diameter.





# RCWall

Computer room air handler unit (CRAH), ideal for hyperscale datacentres where maximum cooling capacity is required for footprint.

## Key Features

- No false floor required
- Modular design - Stackable to achieve x2 cooling capacity without increase footprint
- Latest EC fan technology
- Flexible connections either side or top to
- Reduced installation cost & time
- Dual power and fast restart



**RCWall CRAH Units** (Computer room air handler)

MODEL	081	091	131	151	201	231
TOTAL COOLING CAPACITY (kW)	77	91	131	153	198	232
AIRFLOW (m <sup>3</sup> /h)	21150	24800	34400	40300	47500	55700
DIMENSIONS (mm)	Length	1800	1800	2700	2700	3600
	Depth	1600	1600	1600	1600	1600
	Height	1750	2000	1750	2000	1750



**RCWall CRAH Units** (Computer room air handler)

MODEL	162	182	262	302	402	462
TOTAL COOLING CAPACITY (kW)	154	182	262	307	397	465
AIRFLOW (m <sup>3</sup> /h)	42300	49600	68800	80600	95000	111400
DIMENSIONS (mm)	Length	1800	1800	2700	2700	3600
	Depth	1600	1600	1600	1600	1600
	Height	3500	4000	3500	4000	3500



## Multi Density

### R410A Close Coupled Precision Air Conditioning

Mitsubishi Electric's new Multi Density systems combine the efficiency, quality and simplicity of VRF with high performance close coupled air conditioning units.

Multi Density is ideal for applications where high sensible cooling and close control of temperature in high density applications is required. This system consists of multiple indoor 'coolside' close coupled air conditioners connected to a City Multi VRF outdoor unit. The result is a full inverter multi-split system, designed according to the best quality standards and dedicated to the most reliable IT environments.

The range is particularly suitable for high density racks and blade server cooling in data centres. It is able to cope the high density of the thermal load, putting the air conditioning unit directly within the rows of racks to cool the localised heat sources (hot spots).

#### Key Features

- High Efficiency - full Mitsubishi Electric inverter technology
- Small footprint
- Pipe runs up to 165m
- Trusted VRF technology



CRAC UNITS (Computer Room Air Conditioner)		m-MRAC-Z G02 F/S 009 m-MROW-Z G02 F/S 009	m-MRAC-Z G02 F/S 015 m-MROW-Z G02 F/S 015	m-MRAC-Z G02 F/S 025 m-MROW-Z G02 F/S 025
COOLING CAPACITY (kW) <sup>*1</sup>	Total	10.6	16.6	28.6
	Sensible	9.6	15.7	27.4
SHR <sup>*2</sup>		0.91	0.94	0.96
EC SUPPLY FAN (no.)		2	4	5
AIRFLOW (m <sup>3</sup> /h)		1,500	2,700	4,200
NOMINAL EXTERNAL STATIC PRESSURE (Pa)		20	20	20
MAX EXTERNAL STATIC PRESSURE (Pa)		60	60	60
POWER INPUT (kW) <sup>*3</sup>		0.18	0.34	0.85
REFRIGERANT		R410A	R410A	R410A
REFRIGERANT CIRCUITS (n°)		1	1	1
AIR FILTERS	NO.	2	2	2
	Extended filtering surface (m <sup>2</sup> )	0.35	0.35	0.35
	Efficiency [ISO EN 16890] (COARSE)	40%	40%	40%
SOUND LEVEL [ISO 3744] (dB(A)) <sup>*4</sup>	Pressure Level	63.5	64.5	70.5
	Power Level	79	80	86
POWER SUPPLY (V / Ph / Hz)		230 / 1 / 50	230 / 1 / 50	230 / 1 / 50
ABSORBED CURRENT (A) <sup>*3</sup>		0.8	1.5	4
STARTING CURRENT (A)		2.9	5.8	7.3
DIMENSIONS (mm)	Width	300	300	300
	Depth (MROW / MRAC)	1000 / 1200	1000 / 1200	1000 / 1200
	Height	2,085	2,085	2,085
NET WEIGHT (kg)	In-Row	175	190	193
	Enclosure	185	200	203
CONNECTIONS	Refrigerant pipes diameter - Gas (Ø Inch)	3/4"	7/8"	1"
	Refrigerant pipes diameter - Liquid (Ø Inch)	1/2"	5/8"	3/4"
	Condensate (Ømm) <sup>*5</sup>	16	16	16
	Power supply wiring cable (no. x mm <sup>2</sup> ) <sup>*6</sup>	3G1.5	3G1.5	3G1.5

OUTDOOR UNITS		m-MOCU-Z G02 050	2 x m-MOCU-Z G02 050
RATED COOLING CAPACITY	kW	50	50 x 2
SYSTEM EER <sup>*2</sup>	kW/kW	2.96	3.24
SOUND PRESSURE LEVEL (dB(A))	Cooling	65	68
WEIGHT (kg)		304	304 x 2
DIMENSIONS (mm)	Width x Depth x Height	1650 x 740 x 1750	1650 x 740 x 1750 [x2]
POWER SUPPLY (V / Hz)		380-415v, 50Hz	380-415v, 50Hz
PHASE		3	3
OUTDOOR POWER INPUT (kW)	Cooling (nominal)	15.2	13.7
STARTING CURRENT (A)		27.8	27.8 x 2
MAX RUNNING CURRENT (A)	Cooling	37.6	37.6 x 2
FUSE RATING (BS88) - HRC (A)		40	40 x 2
MAINS CABLE	No. Cores	5G6	5G6
MAX PIPE LENGTH (m)		165	165
MAX HEIGHT DIFFERENCE (m)		50 (40 <sup>**7</sup> )	50 (40 <sup>**7</sup> )
CHARGE REFRIGERANT (kg) / CO <sub>2</sub> EQUIVALENT (t)	R410A (GWP 2088)	11.8 / 24.6	11.8 / 24.6 x 2
GUARANTEED OPERATING RANGE (°C)	Max Temp	45	45
	Min Temp	-15	-15

**Notes:** THE COOLING CAPACITY DOES NOT CONSIDER THE SUPPLY FAN MOTOR THERMAL LOAD. \*1 All data are refers to the Rating Configuration with 2x m-MROW-Z G02 F/S 025 @35°C Outdoor Temperature and 35°C/27°C/h Indoor Temperature. \*2 SHR = Sensible cooling capacity / Total cooling capacity. \*3 Corresponding to the nominal ESP=20Pa. \*4 Sound pressure level on air return at 1m. \*5 Rubber pipe - refers to internal diameter. \*6 Minimum section. It's possible to connect indoor units with a sum of sizing from 25 to 75. These units contain <HFC R410A [GWP100 2088]> fluorinated greenhouse gas. \*7 When outdoor unit is below indoor unit.

# Mitsubishi Electric is a market leader in providing solutions to cool, heat, ventilate and control our buildings

As a major manufacturer of these pivotal technologies, we hold the UK's energy challenges close to our heart.

We want to help the nation achieve its climate goals; we want to help individuals and businesses reduce the energy consumption of their buildings, whilst also helping to reduce their annual running costs.

For more information visit:

[les.mitsubishielectric.co.uk](https://les.mitsubishielectric.co.uk)



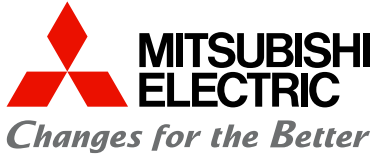

**Telephone: 01707 282880**

MELSmart Technical Services: 0161 866 6089

Technical Help - option 1

Warranty - option 3

Training - option 6 followed by option 1

email: [air.conditioning@meuk.mee.com](mailto:air.conditioning@meuk.mee.com)

website: [airconditioning.mitsubishielectric.co.uk](http://airconditioning.mitsubishielectric.co.uk)

microsite: [thinkTCooling.co.uk](http://thinkTCooling.co.uk)

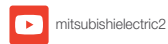
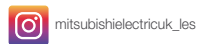
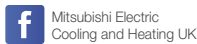

#### **UNITED KINGDOM Mitsubishi Electric Europe Living Environmental Systems Division**

Travellers Lane, Hatfield, Hertfordshire, AL10 8XB, England. Telephone: 01707 282880 Fax: 01707 278881

#### **IRELAND Mitsubishi Electric Europe**

Westgate Business Park, Ballymount, Dublin 24, Ireland. Telephone: (01) 419 8800 Fax: (01) 419 8890 International code: (003531)

Country of origin: United Kingdom - Japan - Thailand - Malaysia. ©Mitsubishi Electric Europe 2022. Mitsubishi and Mitsubishi Electric are trademarks of Mitsubishi Electric Europe B.V. The company reserves the right to make any variation in technical specification to the equipment described, or to withdraw or replace products without prior notification or public announcement. Mitsubishi Electric is constantly developing and improving its products. All descriptions, illustrations, drawings and specifications in this publication present only general particulars and shall not form part of any contract. All goods are supplied subject to the Company's General Conditions of Sale, a copy of which is available on request. Third-party product and brand names may be trademarks or registered trademarks of their respective owners.

**Note:** The fuse rating is for guidance only. Please refer to the relevant databook for detailed specification. It is the responsibility of a qualified electrician/electrical engineer to select the correct cable size and fuse rating based on current regulation and site specific conditions. Mitsubishi Electric's air conditioning equipment and heat pump systems contain a fluorinated greenhouse gas, R410A (GWP:2088), R32 (GWP:675), R407C (GWP:1774), R134a (GWP:1430), R513A (GWP:631), R454B (GWP:466), R1234ze (GWP:7) or R1234yf (GWP:4). \*These GWP values are based on Regulation (EU) No 517/2014 from IPCC 4th edition. In case of Regulation (EU) No.626/2011 from IPCC 3rd edition, these are as follows. R410A (GWP:1975), R32 (GWP:550), R407C (GWP:1650) or R134a (GWP:1300).

Effective as of February 2022



[www.greengateway.mitsubishielectric.co.uk](http://www.greengateway.mitsubishielectric.co.uk)

Mitsubishi Electric UK's commitment to the environment