

the **HAMWORTHY**

STRATTON mk3



Wall hung condensing boiler



SCAN
ME

hamworthy-heating.com

sales@hamworthy-heating.com | 01202 662500



Contents

04 Introduction to the range

9 Hydraulic schemes

17 Service and warranty

06 Features and benefits

10 Product specification

18 The Hamworthy difference

07 Technical information

12 Optional accessories

19 Aftersales support and product training

08 Technical dimensions

15 Flues

A *solution* for every plant room.



• Trusted expertise since 1914.

Hamworthy Heating is a British commercial heating manufacturer.

Our energy efficient commercial heating, hot water, and renewable energy products are used in buildings across the UK.

Trusted expertise since 1914.



Introducing the Stratton mk3

The Stratton mk3 is a wall hung condensing boiler offering a small and durable solution suitable for even the tightest plant rooms. Particularly suited to low height plantrooms, the boiler is less than 2 metres from ground to the top of the frame when mounted on our low height pipe kit.

There are 7 models in the range with outputs from 40kW to 150kW. Depending on the boiler model, you can also cascade up to 6 units at a time to meet the building demands effectively. Outstanding efficiency in excess of 108% nett keeps operating costs to a minimum, and the pre-mix burner technology gives clean operation with ErP Class 6 NOx emissions. Also featuring a durable stainless steel heat exchanger, this boiler offers exceptional system tolerance.

A full range of frame and header kits, associated pumps and accessories are available to support system design, please see page 12 for more details.

Key features



Cascade

Cascade to suit building demands



Wall hung condensing boiler



ErP rating

ErP Class A



NOx Emissions Class 6

NOx emission Class 6



Part L

Fully Part L compliant



5 Yr Warranty

5 year warranty *



Suitable for commercial properties



BIM Objects

BIM objects available to download

** 5 year warranty.
Terms and conditions apply.*

● When installed with a plate heat exchanger or low loss header, the Stratton mk3 can be fitted to old systems with peace of mind that the new boiler is protected from dirt and debris in an existing secondary circuit.



Our range of system separation plate heat exchangers are extremely compact and resilient with a gasket-free brazed design. They comprise of 316 stainless steel plates with copper brazing and are AHRI certified. Kits are supplied for connection straight onto the frame and header kit.

Image taken at the Hull and East Yorkshire Centre for the Deaf. The full case study may be found on our website. Scan to view more.



Get in touch

Contact your local Hamworthy sales team for more information:
hamworthy-heating.com/Contact-us

Features and benefits



Key product features

- 7 models available with 40, 60, 70, 80, 100, 120, 150kW output models
- Wall hung condensing boiler
- Stainless steel heat exchanger for added durability
- Low height for tight plantrooms
- Up to 5:1 turndown ratio
- Up to 97% gross seasonal efficiency
- NOx class 6
- Single units can be cascaded for larger installations
- Advanced sequence control for up to 16 boiler modules
- Easy access for service and system cleaning
- Connections in recess at base of the boiler
- Suitable for natural gas (all sizes) and LPG (up to 120kW) applications
- Full range of hydraulic separation options available
- Room sealed flue options



Technical information

	Units	S3-40	S3-60	S3-70	S3-80	S3-100	S3-120	S3-150*	
Energy	Building Regulations Part L seasonal efficiency	% gross	97.6	97.4	97.5	97.5	97.5	97.8	
	ErP efficiency rating		A	A	A	N/A	N/A	N/A	
	Maximum boiler output (80-60 Deg C, NG & LPG)*	kW	38.8	53.4	67.8	77.8	93.4	116.8	141.1
	Maximum boiler output (50-30 Deg C, NG & LPG)*	kW	42.2	58	73.6	84.4	101.3	127.8	154.5
	Minimum boiler output (80-60 Deg C, NG & LPG)*	kW	8	11	14	19.2	19.2	24	29
	Standby losses	W	52	54	56	63	63	72	69
Water	Water content	litres	3	4	4.5	7.5	7.5	9.5	11
	Nominal water flow rate	l/sec	0.48	0.66	0.83	1.16	1.19	1.43	1.73
	Minimum water flow rate	l/sec	0.16	0.32	0.32	0.64	0.64	0.83	0.96
	System design flow rate @ 11 Deg C rise	l/sec	0.87	1.19	1.52	1.73	2.17	2.6	3.14
	Water pressure loss @ 11 Deg C rise	mBar	1539	1560	1890	1043	1457	1648	2278
	System design flow rate @ 20 Deg C rise	l/sec	0.48	0.72	0.84	0.96	1.19	1.43	1.79
	Water pressure loss @ 20 Deg C rise	mBar	459	470	520	318	449	515	701
	System design flow rate @ 25 Deg C rise	l/sec	0.38	0.52	0.67	0.76	0.95	1.14	1.38
	Water pressure loss @ 25 Deg C rise	mBar	223	305	306	203	287	335	441
	Minimum water pressure (cold)	barg	1	1	1	1	1	1	1
	Maximum water pressure	barg	4	4	4	6	6	6	6
	Maximum flow temperature	Deg C	85	85	85	85	85	85	85
Gas	Maximum gas inlet pressure (NG)	mBar	25	25	25	25	25	25	25
	Nominal gas inlet pressure (NG)	mBar	20	20	20	20	20	20	20
	Minimum gas inlet pressure (NG)	mBar	17	17	17	17	17	17	17
	Maximum gas inlet pressure (LPG)	mBar	45	45	45	45	45	45	N/A
	Nominal gas inlet pressure (LPG)	mBar	37	37	37	37	37	37	N/A
	Minimum gas inlet pressure (LPG)	mBar	25	25	25	25	25	25	N/A
	Maximum gas flow rate (NG)	m3/hr	4.2	5.8	7.4	8.5	10.2	12.7	15.3
	Maximum gas flow rate (LPG)	m3/hr	1.6	2.3	2.9	3.3	3.9	4.9	N/A
Flue	Maximum flue gas temperature (80-60 Deg C, NG)	Deg C	79	75.5	74.5	66.5	72.5	73.5	73
	Dry Nox emission (0% excess oxygen, dry air free)	mg/kWh	36	39	39	39	39	39	39
Elec	Electrical supply		230V AC/50Hz	230V AC/50Hz	230V AC/50Hz	230V AC/50Hz	230V AC/50Hz	230V AC/50Hz	230V AC/50Hz
	Power consumption (at maximum modulation)	W	67	107	121	94	143	233	260
Misc	Approx. shipping weight (empty)	kg	45	51	55	77	77	81	100
	Noise emission @ 1M (maximum modulation)	db (A)	50	59	60.2	67.7	64.7	64.9	59.2

* LPG option for 150kw is not available

Technical dimensions

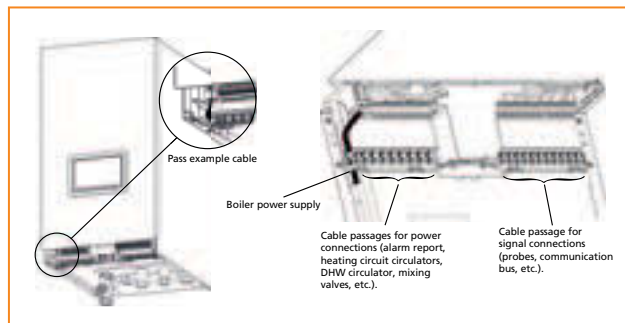
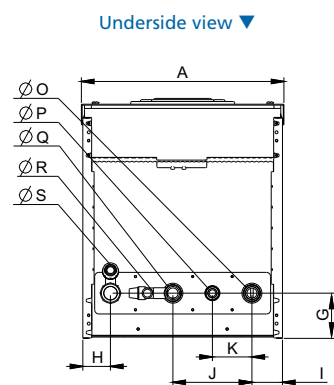
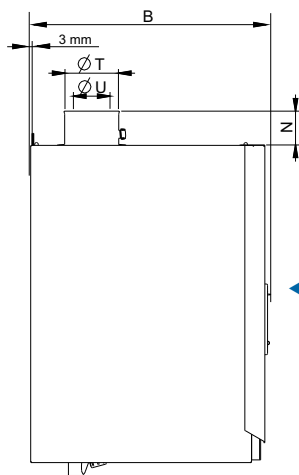
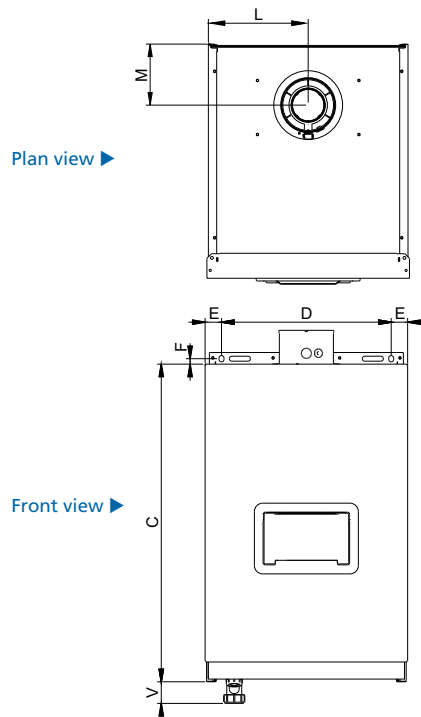

		Boiler Models in kW						
		S3-40	S3-60	S3-70	S3-80	S3-100	S3-120	S3-150
A	Boiler width			487				
B	Boiler depth	577				668		
C	Boiler height	764				895		
D	Fixing centers			408				
E	Distance of fixings to side of boiler			36				
F	Fixing point centers above top of casing			17				
G	Center of connections to rear of boiler			108,5				
H	Center of siphon outlet to side casing	66,5				65,5		
I	Center of return connection from casing side	73,5				74,5		
J	Centers between flow and return connections			190				
K	Centers between gas inlet and return connection			95				
L	Center of flue from side			240				
M	Center of flue from rear	146,5				123		
N	Flue connection socket height			83				
Ø O	Return connection			G 1"¼				
Ø P	Gas inlet connection			G 1"				
Ø Q	Flow connection			G 1"¼				
Ø R	Pressure relief valve			G ½" (female)				
Ø S	Condensate outlet	(mm)		24				
Ø T	Air inlet	(mm)		125		150		
Ø U	Flue duct	(mm)		80		100		
V	Siphon outlet from the bottom of the casing	(mm)		52				

Recommended Clearance – All Models

Front: 800mm Sides: 250mm* Top: Dependent on flue choice

* Side clearance is preferred but not compulsory.

Hydraulic schemes

Scheme 1: Sealed system with low loss header

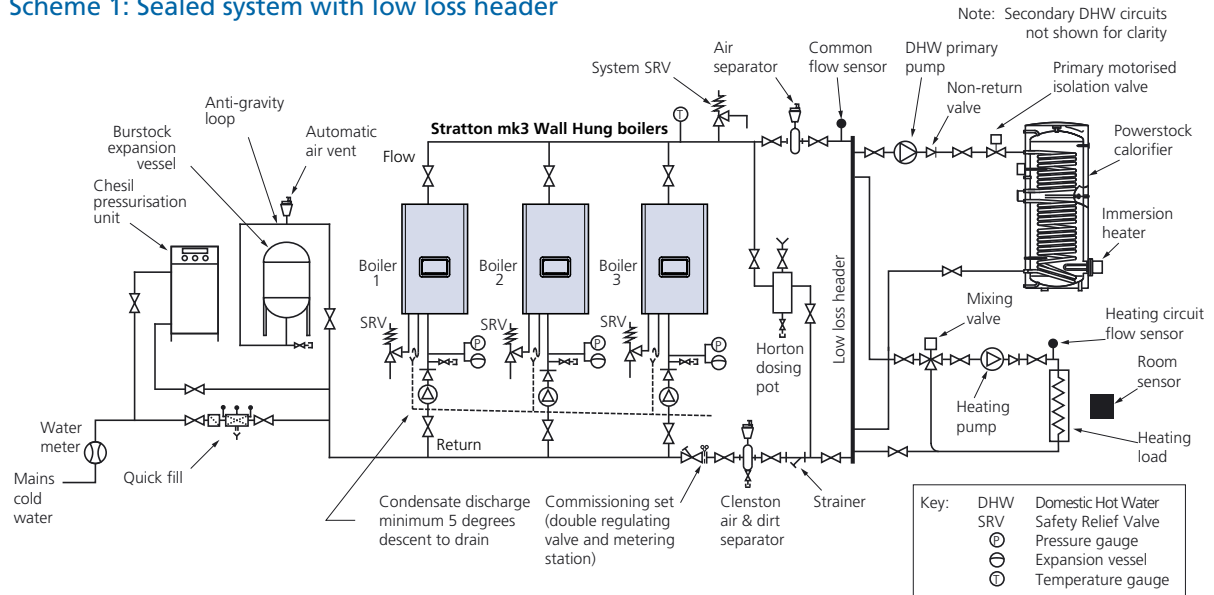

Scheme 2: Sealed primary and open-vented secondary system with plate heat exchanger separation and without a low loss header

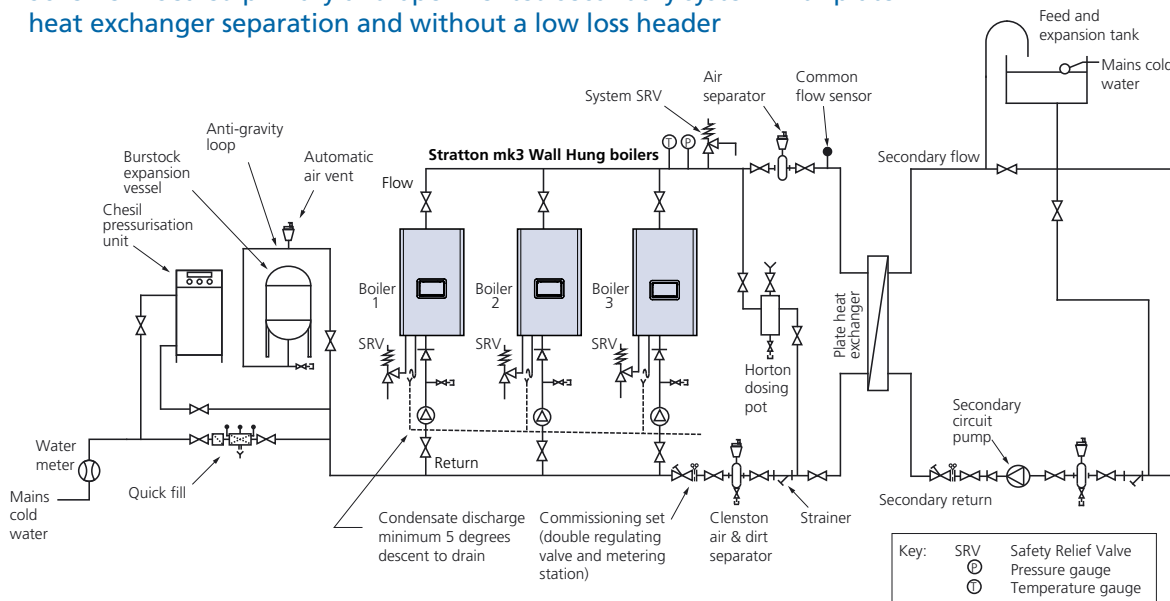

Note: These schematics have been provided for reference only.

Hydraulic circuits should never impede circulation through the boilers. The use of a low loss header is strongly recommended, or use of a plate heat exchanger for hydraulic separation to ensure adequate boiler flow.

Product specification

Pre-mix burner

Stratton mk3 boilers feature a pre-mix burner for clean combustion with low ErP Class 6 emissions. Full modulation from 20% to 100% output is managed from the boiler control varying the fan speed and gas input to deliver correct gas air ratio across the range of modulation. With Class 6 NOx emissions of less than 40mg/kWh across the range, Stratton mk3 combines high efficiency with low emissions to suit modern installations.

The burner head features spark ignition with flame detection provided by flame ionisation probe.

Heat exchanger

Using stainless steel heat exchangers throughout the boiler range makes the Stratton mk3 boiler very tolerant to varying water conditions in both new and existing systems. Manufactured from 316L grade stainless steel gives a high resistance to corrosion and a long life backed by a 5-year heat exchanger warranty.

The design of flue passages and waterways within the heat exchanger matched with optimised combustion ensure highly efficient operation. Part load efficiency exceeds 108% nett for all models when operating in suitable system conditions.

Operating efficiency

Dependent on operating temperatures the Stratton mk3 boiler is capable of delivering high efficiency with part load efficiency in excess of 108% nett and full load efficiency exceeding 97% nett across the whole boiler range.

The boiler range exceeds the minimum requirements of Building Regulations Part L and European ErP legislation for both new and existing buildings.

Fuel supply

Stratton mk3 boilers are certified for operating with Natural Gas and LPG. Factory set to operate with Natural Gas, boilers up to 120kW can be site adjusted for operation using LPG requiring parameter changes and gas orifice replacement as part of the commissioning process. Each boiler is supplied with the required parts to facilitate conversion to LPG firing if required.

Boiler model S3-150 is not suitable for operation with LPG.

System connections

All connections for flow, return and gas are located in a recess on the underside of the boiler enabling the boiler to be stood flat on the ground and reducing the potential for damage during the installation process.

Condensate discharge

Condensate from the combustion process is safely removed from the heat exchanger via a syphon trap to the outside of the boiler. This allows condensate to flow safely but prevents the escape of flue gases via the drain.

Water pressure sensor

The Stratton mk3 is only suitable for pressurized system. The boiler is protected from both high and low water pressure conditions. Water pressure within the boiler is monitored by the integral sensor and the boiler prevented from operating under the following conditions:

- **High pressure**
The burner is prevented from firing should internal boiler pressure raise above operational parameters and released for operation once the pressure drops to 3.8 bar.
- **Low pressure**
The burner is reduced to 20% modulation should internal pressure drop below 1 bar, and prevented from firing should internal pressure drop below 0.8 bar. Once the internal pressure recovers to 1 bar the burner operates at 20% modulation until pressure reaches 1.2 bar when full burner modulation resumes.

Water flow switch

Protecting the boiler from inadequate circulation, the integral water flow switch prevents the boiler from firing should the flow rate become too low.

Air pressure switch

A differential air pressure switch monitors air flow through the flue passages of the boiler to ensure there is adequate air flow before the burner is permitted to light. This offers protection from operation with a blocked flue or a poorly maintained and blocked burner.

Temperature controls

Stratton mk3 boilers can operate independently using their integral temperature control. Flow temperature is monitored using an electronic flow temperature sensor with a corresponding maximum set point of 85°C. The boiler control will modulate the burner set point back as the temperature set point is approached for near continuous operation with minimum cycling.

The boiler control can also be configured to receive a 0-10 volt analogue BMS signal to define either the temperature set point up to the maximum 85°C, or the burner load setting up to the maximum 100% output.

Each boiler is additionally fitted with a manual reset high limit thermostat factory set to 95°C but which can be set up to a maximum of 110°C dependent on application.

Flues

Stratton mk3 boilers are suitable for open flue and room sealed flue systems.

A concentric flue connection is located centrally towards the top of each boiler allowing compact flue arrangements above the boiler.

Optional flue kits are available for individual boilers to enable room sealed connections. The flue can be terminated both horizontally and vertically within permitted legislative requirements.

A Hamworthy or approved flue connection kit is mandatory for all flue installations.

Flue gas non-return valves

An integrated flue gas non-return valve is located between the burner and fan. This is to prevent any possibility of flue gas recirculating through non-firing modules in a multiple boiler configuration, making it easier to install with common flue headers whilst reducing height requirements above the boiler.

Pipe & frame kits

Hamworthy offers a choice of pipe and frame kits to aid ease of installation. Available for single boiler applications or for up to six boilers (dependent on size). The frame kit is also available separately where weak walls or a standalone requirement is present.

System separation

The boiler must be used with a low loss header or PHEX (available as options) to provide hydraulic separation from the heating circuits, thus ensuring flow conditions within secondary circuits cannot adversely affect operation of the boiler. Hamworthy can supply low loss headers for up to six boiler modular arrangements.

Wall mounting

To aid installation, each boiler is provided with a wall mounting plate to fix to the wall ahead of hanging the boiler. Once secured to the wall the boiler simply hooks onto the wall bracket.

Primary circulation shunt pump

A dedicated pump can be connected to each boiler module and controlled by the boiler controls platform for primary circulation. The pumps are part of the pipe and frame kit when purchased from Hamworthy.

Optional accessories

Hydraulic separation is vital when installing new condensing boilers on old systems. Protecting the new system from dirt and debris in the secondary system will prolong the life of the new boiler. The Stratton mk3 is available with a range of hydraulic separation system accessories as a single boiler installation or as a cascade.

Boiler (kW)	Max Boilers in Cascade	Frame & Header Kit	Low Loss Header	PHEX Kit
40	6			
60	5	DN50	DN50	Up to 300kW to match cascade output
70	4			
80	6			
100	6	DN80	DN80	Up to 600kW to match cascade output
120	5			
150	6	DN100	DN100	Up to 900kW to match cascade output

- System separation via PHEX or Low Loss Header
- Frame and header kits incorporate suitable pumps

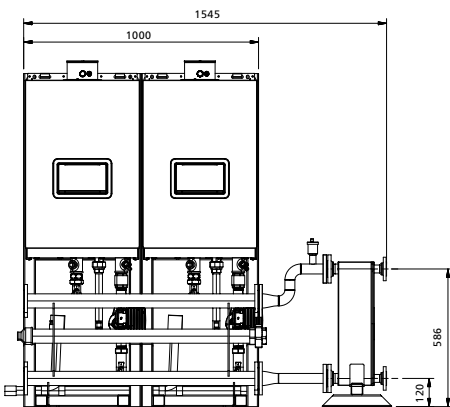

Example:

2 x 60kW boiler in cascade with DN50 frame & header kit plus 150kW PHEX

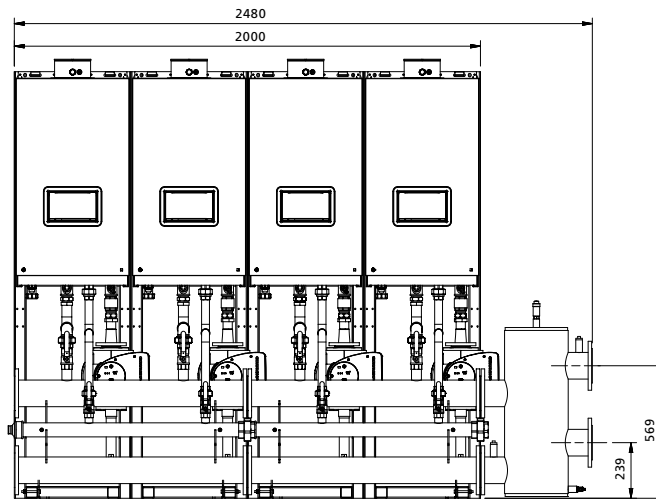

Example:

4 x 150kW boiler in cascade with DN100 frame & header kit plus DN100 low loss header

Plate heat exchangers

- Used to separate systems, allowing two circuits to operate independently
- Ensures boilers can operate under optimum system conditions
- Brazed plate heat exchangers offer compact, resilient, gasket-free design
- Stainless 316 channel plates with copper sealing
- Exchangers AHRI certified
- Low maintenance
- PN6 flange d system connections

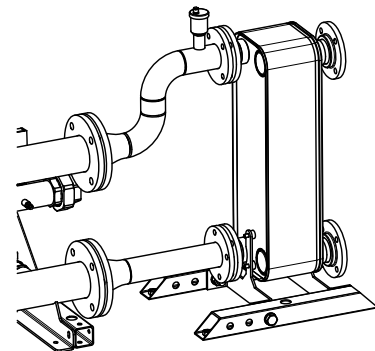

Low loss headers

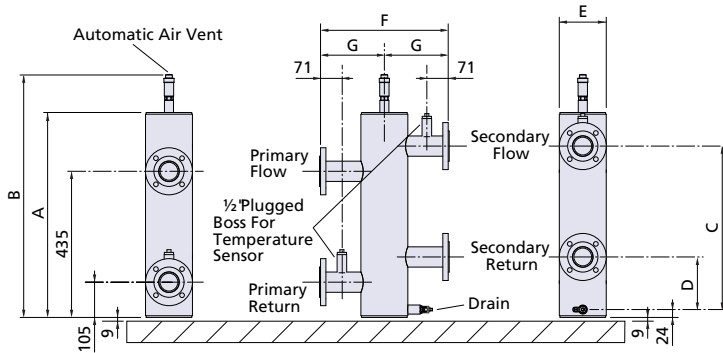

Ref	DN50 S3-40, S3-60, S3-70	DN80 S3-80, S3-100, S3-120	DN100 S3-150
A	700	710	725
B	814	823	839
C	510	535	561
D	180	205	231
E	139.7	219.1	273
F	386	460	480
G	193	230	240

- 1. Used to partially separate systems, allowing two circuits to operate independently
- 2. Ensures boilers can operate under optimum system conditions
- 3. Welded steel construction
- 4. PN6 flanged system connections
- 5. Available DN50, DN80 and DN100 to suit frame and header kit options

Pipe frames and header sets

For multiple boiler installations pipe frame and header sets are available for

one to six boilers. Individual mounting frames are provided for each boiler. Header sets are also available for one and two boilers allowing combinations of up to six boilers to be installed by

simply bolting two header sets together. Pipe kits can be located against a wall or be free standing when using suitable floor tie bolts.

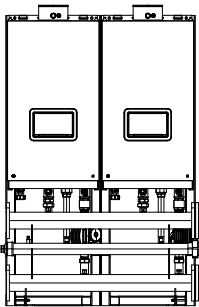

Two boiler assembly

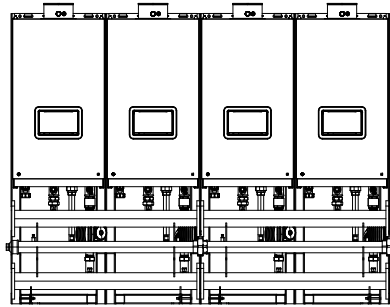

Four boiler assembly

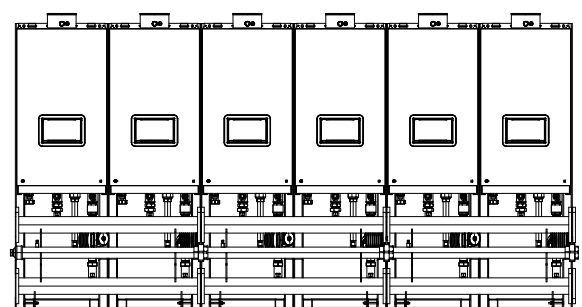

Six boiler assembly

Pipe Kit Size	Boilers Used	Maximum boilers in cascade	1 wide			2 wide			3 wide			4 wide			5 wide			6 wide		
			H (mm)	D (mm)	W (mm)	H (mm)	D (mm)	W (mm)	H (mm)	D (mm)	W (mm)	H (mm)	D (mm)	W (mm)	H (mm)	D (mm)	W (mm)	H (mm)	D (mm)	W (mm)
DN50	40kW	6																		
	60kW	5	1418	685	500	1418	685	1000	1418	685	1500	1418	685	2000	1418	685	2500	1418	685	3000
	70kW	4																		
DN80	80kW	6																		
	100kW	6	1535	704	500	1535	704	1000	1535	704	1500	1535	704	2000	1535	704	2500	1535	704	3000
	120kW	5																		
DN100	150kW	6	1830	794	500	1830	794	1000	1830	794	1500	1830	794	2000	1830	794	2500	1830	794	3000

H Height from floor to top of frame D Depth from installed wall to front of kit W Width of installed kit

Boiler support frames

For single Stratton mk3 boilers providing support where weak walls or standalone requirement is present. Transferring the weight to the floor, multiple frames can be bolted together for modular boiler installations.

* Supplied with header kits as standard

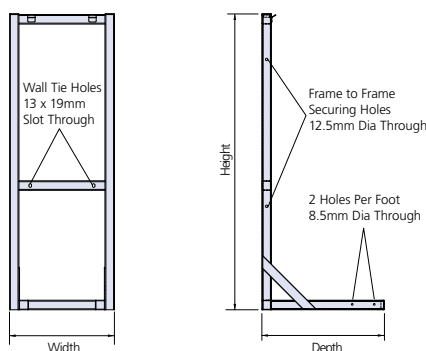

Support frame dimensions			
	Height	Width	Depth
40kW			
60kW	1405	500	680
70kW			
80kW			
100kW	1535	500	700
120kW			
150kW	1830	500	700

Optional accessories

Control units

Controls are available for single boiler installation and multiple boiler installations.



Single boiler controls

All control functions are managed via the Navistem 'boiler management unit' built in to the boiler. With a combination of optional extras the level of control is expandable for up to 3 heating circuits (depending on boiler outputs) and 1 domestic hot water cylinder.

Optional Control Accessories

- **Outdoor temperature sensor QAC34**
Used for frost protection and weather compensation
- **DHW cylinder sensor QAZ36**
Used as DHW sensor in cylinder or as part of heating circuit control
- **Strap-on temperature sensor QAD36**
Used as sensor in primary circuit or as part of heating circuit control
- **Programmable room sensor QAA74**
Communicates with the boiler and offers full adjustment of room temperature, time clock, holiday periods and frost protection settings
- **Offset adjustable room sensor QAA54**
Offers building occupants limited control of operating mode and temperature setting
- **Remote signalling kit AGU2.550A109**
Offers volt free contacts for common fault and normal run indications
- **Heating circuit control kits – boiler mounted AVS75**
Clip-in offers control of additional independent heating circuits

- **Heating circuit control kits – externally mounted AVS75**
Offers control of additional independent heating circuits. For mounting outside boiler
- **LPB bus communication module OCI345**
Clip-in module used with sequence control function. One clip per boiler
- **Modbus gateway module OCI351**
Clip-in module offers connectivity with Modbus PLC system if required
- **Merley sequence controller**
Offers sequence control of up to 15 boiler modules. Offered suitable for external boiler mounting or for fitting to site panel (by others)

Multiple boiler controls

Where Building Management Systems are not present, or independent control of the boilers is required there are two alternative options available from Hamworthy:

1. **Integrated Navistem (LMS)** is available for sequencing of up to 16 boiler modules using integral Master/ Slave feature of control (1 master, 15 slaves).

2. For sequencing of up to 15 boiler modules the **Hamworthy Merley boiler sequence controller** is available for mounting remote to the boiler or within clients own control panel.

Flues

Type B23P open flue systems

B23P pressurised open flues for single boilers include a dedicated flue pipe for removing the flue gases to outside. Combustion air is drawn into the boiler directly through the outer annulus of the concentric flue connection on top of the boiler which is supplied.

A Hamworthy or approved flue connection kit is mandatory for all B23 flue installations.

- > 80, 100, 130, 150 and 200mm flue diameter
- > 90° and 45° flue elbows
- > 500mm and 1000mm length extension pieces
- > Must be sold with the open flue connection kit

Type C13 concentric room sealed flue systems – horizontal

C13 room sealed flues include a concentric flue system designed for termination horizontally through an external wall carrying combustion air from and flue gases safely to the outside.

- > 80 and 100mm flue diameter
- > 90° and 45° flue elbows
- > 500mm and 1000mm length extension pieces

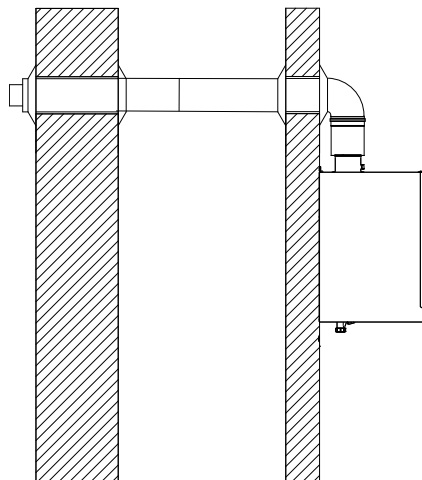

Flues

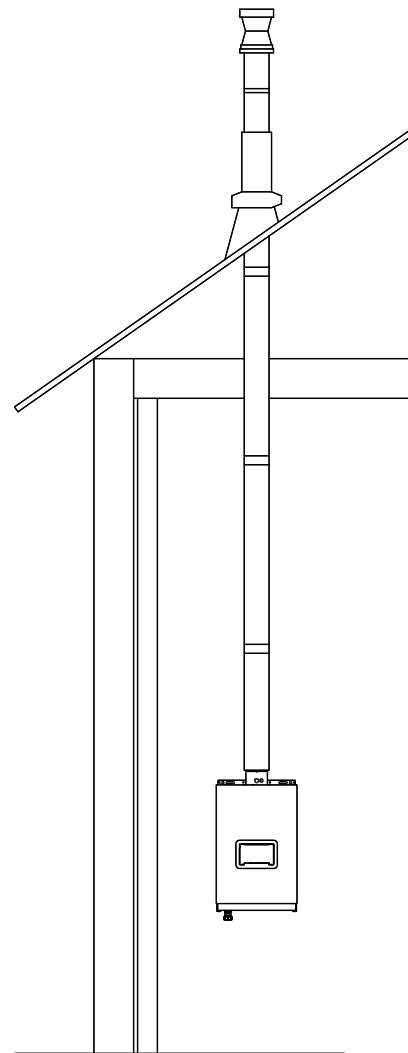

Type C33 concentric room sealed flue systems – vertical

C33 room sealed flues include a concentric flue system designed for termination vertically through a roof carrying combustion air from and flue gases safely to the outside.

- > 80 and 100mm flue diameter
- > 90° and 45° flue elbows
- > 500mm and 1000mm length extension pieces

Flue diameters

Model	40	60	70	80	100	120	150
B23P Open Flue Size	80mm			100mm			
C13 (Horizontal) Room Sealed Flue Size	80/125mm			100/150mm			
C33 (Vertical) Flue Size	80/125mm			100/150mm			

Flue lengths

Concentric Flue Options – Maximum Flue Lengths (m) Natural Gas and LPG							
Model	40	60	70	80	100	120	150*
C33 (vertical)	15	10	10	10	10	8	6
C13 (horizontal)	15	10	10	10	10	8	6

*150kW only available with Natural Gas

For B23 Pressurised open flue performance data please refer to the Stratton mk3 installation manual, page 25, available on the website.

For Concentric flue performance data please refer to the Stratton mk3 installation manual, page 33, available on the website.

Service and warranty

Commissioning

We strongly recommend that all products are commissioned by our service department. As well as ensuring your product is set up correctly for maximum efficiencies you will receive extra benefits on warranty (see below). On completion, you will get a report with details of the initial operating settings.

Service

The Stratton mk3 boiler has been designed with ease of service in mind. The combustion analysis point is easily located on the boiler making it easier for service engineers. The cover is easily removable for access to all the components.

To maintain your boilers, we have a range of servicing options that can be tailored to your requirements. For more information on commissioning and service please contact the Hamworthy Heating service department.

Warranty

The Stratton mk3 comes with a 5 year warranty as standard (terms and conditions apply).

We offer tailored packages to suit the individual customer requirements, many of which include extended warranty benefits. Full details of warranty terms and conditions are available on request.



- **Speak to our service team today to find out more about commissioning and service offering or ask us to add it to your project quote.**

Telephone:
01202 662555

Email:
service@hamworthy-heating.com

Website:
hamworthy-heating.com/commissioning

Spares

Essential to any maintenance and service regime is the availability of quality spare parts.

By coming to us, the Original Equipment Manufacturer (OEM), you can be assured of genuine spare parts and may also benefit from technological improvements. We have a long-term commitment to spare parts for our products.

The Hamworthy difference

Delivery

Each boiler is despatched fully assembled and factory tested with the casing and control panel fitted.

Standard delivery for all Hamworthy products is free of charge.

Boilers are delivered to ground level and are closely co-ordinated with the customer, to suit the site construction programme.

To enquire about special delivery services including FORS and time critical deliveries (additional charges apply), please contact our customer services team.

British engineering excellence

Here in the UK, we design, test, manufacture and source market-leading products.

We know our products inside out, back to front and from start to finish. You can trust that we know what we're talking about.

Everyone's got history, we've got heritage

Our roots date back to 1914 when two brothers in Poole set up Hamworthy Engineering. Decades of experience go in to every nut, screw and bolt, and every phone call, text and email.

Since 2008, we've been part of Groupe Atlantic, a company with a similar ethos to us. Groupe Atlantic was founded in 1968 by two engineers and is now one of the market leaders in the European heating and hot water industry. We're part of their growing UK, ROI and North America Divisions.



Lifetime support

From design and specification, through to commissioning, training and maintenance, as well as commitment to spares availability. We support businesses through their lifetime of commercial heating and hot water needs.



Aftersales support

Got a question?

Don't hesitate to get in touch. Your local contact is listed on the back cover, or speak to one of the team in head office:

Sales team: 01202 662552

Service team: 01202 662555

Spares team: 01202 662525

Technical support: 01202 662505

You can speak to us online via our web chat service or visit our technical library to download full product information including CAD files, BIM objects and data tables.

hamworthy-heating.com

sales@hamworthy-heating.com

Request a free site survey

Our free site survey brings our experts directly to you.

hamworthy-heating.com

sales@hamworthy-heating.com

01202 662500

Product training

Get hands-on training on Stratton boilers

Training can be provided onsite, online or at one of our training centres.

Delivered by Groupe Atlantic engineers with years of product knowledge and industry experience, the training session will provide hands-on product training and guide you through the servicing of products to ensure they are operating at their maximum efficiencies.

We recommend you encourage your customer to attend too so they are confident understanding fault codes and associated control operation.

We're also accredited with CIBSE to deliver approved Continuing Professional Development (CPD) courses.



To enquire about hands-on training or a CPD module with us, please contact your local area sales manager or email **sales@hamworthy-heating.com**

**British engineering excellence from Hamworthy Heating;
the commercial heating and hot water specialists.**



**SUPPORT BRITISH
MANUFACTURING**



Hamworthy Heating Limited

Wessex House,
New Fields Business Park,
Stinsford Road,
Poole, Dorset BH17 0NF

Tel: **01202 662500**
Email: sales@hamworthy-heating.com
hamworthy-heating.com

Hamworthy Heating Accreditations

ISO 9001 Quality Management System
ISO 14001 Environmental Management System
ISO 45001 Health & Safety Management System

Every effort has been taken to ensure the details in this guide are accurate. Hamworthy Heating does not, however, guarantee the accuracy or completeness of any information nor does it accept liability for any errors or omissions in the information.

Hamworthy Heating reserves the right to make changes and improvements which may necessitate alteration to product specification without prior notice.