

ideal
HEATING

COMMERCIAL

EVOMAX 2 CONDENSING BOILER

PRODUCT & FLUE GUIDE



[idealheating.com](https://www.idealheating.com) |     



Commercial/Industrial
Heating Product of
the Year 2020

Ideal Heating is the UK's market leader of high efficiency commercial heating solutions.

Operating from its Hull manufacturing plant and offices since 1906, Ideal is one of the few true British manufacturers left in the heating industry.

BRING BOILERS TO LIFE

Your phone or tablet can let you appreciate our Condensing Boiler range in a new dimension.

The Ideal Heating Eye app uses the latest Augmented Reality technology to project accurately scaled 3D renders into your surroundings.

The app is available for both Apple and Android devices; just search "Ideal Heating Eye".

Over the coming pages, the icon below shows which boilers are featured in the app:



ideal
HEATING

COMMERCIAL

- 2** Introduction
- 4** Evomax 2 30 - 150kW
- 12** Evomax 2 Cascade 30 - 900kW
- 32** Evomax 2 Flue Options
- 45** Flue Types
- 47** Guide to Flue Installation and Regulation
- 54** Condensate Pumps
- 57** Ideal Training & Support



British
Built



Industry
Trusted



Commercial/Industrial
Heating Product of
the Year 2020

EVOMAX 2

30 - 150kW



DOWNLOAD
THE APP



improved

EVOMAX 2

30 - 150kW

Available in outputs of 30, 40, 60, 80, 100, 120 and 150kW, Evomax 2 is designed to ensure all installation requirements can be achieved. There is also an LPG Evomax range from 30 to 120 kW for off mains installations.



Wall Hung



BIM



NOx
Class 6



Flueing
options



Cascade
control



Part L
2022

FEATURES & BENEFITS

- **Free Commissioning**
- 5 year warranty*
- Robust cast aluminium silicon alloy heat exchanger
- NOx <40mg/kWh (Class 6) for all natural gas models
- High 5:1 turndown
- Up to 99.6% full load efficiency
- Up to 110% part load efficiency
- Exactly the same compact footprint as Evomax, allowing for easy like for like replacement
- Dynamic control menu set up
- Cascade controls option
- Easy servicing; 3 sides removable
- Built in, serviceable flue Non-Return Valve
- Capable of operating at up to 30° ΔT

Applies to Evomax 2 30, 40 and 60kW models only.

DIMENSIONS & CLEARANCES

BOILER	DIM A	DIM B
30, 40, 60, 80	360	130
100, 120	520	226
150	610	233

All dimensions in mm

The following minimum clearances must be maintained for operation and servicing:



CLEARANCE BETWEEN MULTIPLE BOILER INSTALLATIONS: 25mm

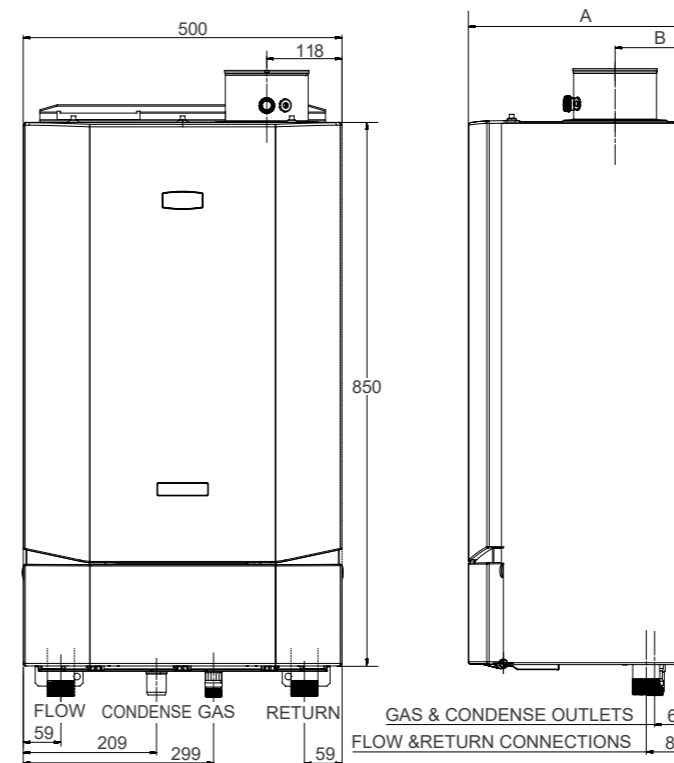

BOILER ASSEMBLY

INTERNAL VIEW
(40kW MODEL SHOWN)

KEY

1. Auto Air Vent
2. Burner Fixings
3. Fan
4. Gas Valve
5. Venturi
6. Flow Thermistor
7. Ignitor Unit
8. Electrode Detection
9. Ignition Electrode
10. Water Pressure Sensor

PERFORMANCE DATA

EVOMAX 2 30 - 150kW (Natural Gas)

MODEL			30	40	60	80	100	120	150
Boiler Output (non-condensing) Mean 70°C	Max	kW	30	40	60	80	100	120	150
	Min	kW	6	8	12	16	20	24	30
Boiler Output (condensing) Mean 40°C	Max	kW	31.5	42.0	63.5	84.4	103.9	124.7	158
	Min	kW	6.5	8.5	12.7	17.2	21.6	26.0	32.5
Boiler Input Max Rate	Net	kW	30.4	40.5	60.8	82.0	102.4	122.9	153.7
	Gross	kW	33.7	44.9	67.4	90.9	113.6	136.4	170.5
Boiler Input Min Rate	Net	kW	6.1	8.1	12.2	16.4	20.5	24.6	30.7
	Gross	kW	6.7	9.0	13.5	18.2	22.7	27.3	34.1
Gas Rate	Max rate	m³/hr	3.2	4.3	6.4	8.7	10.8	13.0	16.2
Flue Gas Flow Rate	Max Rate	m³/hr	41.30	54.05	80.65	110.10	140.50	173.33	210.70
	Min Rate	m³/hr	1.26	1.69	2.53	3.41	4.35	5.23	6.23
CO ₂ (±0.5%)	Max Rate	%	9.76	10.20	9.40	9.30	9.40	9.62	9.44
	Min Rate	%	8.56	8.60	8.60	8.70	8.60	8.98	8.51
NOx with O ₂ = 0% (gross) (BS EN 15502-1)	Weighted	mg/kWh	34.1	33.2	35.2	34.9	34.8	33.9	35.7
Efficiency	Seasonal	%	96.7	96.2	96.4	97.2	96.7	96.6	96.7
	*SEDBUK 2009	%	89.6	89.3	89.4	n/a	n/a	n/a	n/a
Operating Temperature Sealed (Open)	Max	°C	85 (82)						

EVOMAX 2 30 - 120kW (LPG)

MODEL			30P	40P	60P	80P	100P	120P	
Boiler Output (non-condensing) Mean 70°	Max	kW	30	40	60	80	100	120	
	Min	kW	6	8	12	16	20	24	
Boiler Output (condensing) Mean 40°C	Max	kW	30.9	41.2	62.1	82.6	101.7	123.3	
	Min	kW	6.4	8.3	12.4	16.8	21.3	25.7	
Boiler Input Max Rate	Net	kW	30.4	40.5	60.7	81.9	102.4	122.9	
	Gross	kW	33	44	66	88.9	111.2	133.4	
Boiler Input Min Rate	Net	kW	6.1	8.1	12.0	16.2	20.5	24.6	
	Gross	kW	6.6	8.8	13.1	17.5	22.2	26.7	
Gas Rate	Max rate	m³/hr	1.26	1.69	2.53	3.41	4.35	5.23	
Flue Gas Flow Rate	Max Rate	m³/hr	44.09	61.68	88.66	121.57	153.60	183.81	
	Min Rate	m³/hr	1.26	1.69	2.53	3.41	4.35	5.23	
CO ₂ (±0.5%)	Max Rate	%	10.9	11.2	11.4	11.4	10.8	11.2	
	Min Rate	%	10.3	9.7	10.2	10.8	10.1	10.1	
NOx with O ₂ = 0% (gross) (BS EN 15502-1)	Weighted	mg/kWh	52.3	64.4	67.7	63.2	65.3	41.6	
Efficiency	Seasonal	%	97.2	96.7	96.9	97.7	96.7	96.6	
	*SEDBUK 2009	%	90.6	90.3	90.5	n/a	n/a	n/a	
Operating Temperature Sealed (Open)	Max	°C	85 (82)						

GENERAL DATA

EVOMAX 2 30 - 150kW (Natural Gas & LPG)

MODEL		30/30P	40/40P	60/60P	80/80P	100/100P	120/120P	150
Gas Supply		2H - G20 - 20mbar / 3P - G31 - 37mbar						
Gas Supply Connection		G ¾"						
Flow Connection		G1 ¼"						
Return Connection		G1 ¼"						
Max Pressure (sealed system)	Bar (psi)	6						
Maximum Static Head	m	6l						
Electricity Supply		230V - 50Hz						
Fuse Rating	A	4.0						
Power Consumption	W	81	138	82	149	187	243	240
IP Rating		IPX4D						
Nominal Flue Size (concentric)	mm	80/125*				100/150		
Condensate Drain	mm	25						
Water Content	l	3.0		5.0		7.0		9.2
Dry Weight	Kg	47.5		57.5		73		81
Weighted Sound Power Level	dBA	55.2	57.7	59	59.9	62	62	59

*Optional kit available on 60kW and 80kW models for 100/150mm flue

INCLUDED AS STANDARD

BOILER	EVOMAX 2
Remote indication (run & alarm)	✓
Hours run	✓
BMS (0-10v) operation	✓
Pump overrun	✓
Large backlit LCD controls, including 5 line plain text display	✓
Dynamic control menu set up	✓

OPTIONAL KITS

BOILER	EVOMAX 2
Multi boiler frame & header kits (see pages 16-19)	✓
Varican Module Master Kit	✓
Varican Module Slave Kit	✓
Extension Module Kit	✓
OPENTHERM Room Control Kit	✓
Room Sensor Kit	✓
Tank Sensor Kit	✓
Outside Sensor Kit	✓
Header Flow Tank Immersion Sensor Kit	✓
Header Flow Tank Strap On Sensor Kit	✓
Safety Interlock Kit	✓
0-10V Pump Control Kit	✓
Condensate Pump	✓

SUGGESTED ENGINEERING SPECIFICATION

The Suggested Engineering Specification is wording designed for specifiers to copy and paste into their specifications to ensure inclusion of Ideal Heating commercial boilers.

OVERVIEW

The boilers must be fully automatically controlled, wall mounted, fanned, super-efficient condensing appliances utilising an aluminium silicon alloy heat exchanger and be suitable for connection to fully pumped open vented or sealed water systems.

CONTROLS

The condensing boilers must have connectivity for all common types of BMS integration including 0-10v, volt free and OpenTherm connections. Additional modules may be used for BACnet, LONWorks and MODBus gateways. Where no BMS is present a modulating sequencer must be available.

The boiler must be fully modulating with a 5:1 turndown ratio and include control features enabling set point adjustment, heating circuit control of one constant temperature and one DHW circuit or 2 constant temperature circuits, and safety lock out parameters including fault diagnosis for both boiler and external components such as sensors or pumps.

Boiler capabilities must include, with the use of external components, frost protection, weather or room compensation and system pump control.

FLUE

The condensing boilers must be suitable for use with a room sealed flue or open flue applications including C13, C33 and B23 classifications. The combined flue outlet and air inlet must be situated on the top of the boiler.

HYDRAULIC

The condensing boiler must be and be suitable for connection to fully pumped open vented or sealed water systems. All hydraulic connections including flow return and condensate drain must be located on the bottom of the boiler. Hydraulic connections must be uniform across the outputs available in the range to ensure ease of installation and maintenance in mixed output cascades. The boiler must have a maximum operating pressure of 6 bar and be suitable for heating and indirect hot water systems.

DIMENSIONS

The condensing boiler range must have a universal compact width and height across the range to ensure mixed output cascades maintain the same universal configuration. Maximum permitted wall area of 0.43m².

MOUNTING

The condensing boilers can be installed either on the wall or into a prefabricated floor mounted frame. Wall brackets must be located at the top of the boiler and visible from the front to aid installation.

EFFICIENCY

The condensing boilers are capable of high seasonal efficiencies with a minimum requirement of 96.2% and low NOx emissions no greater than 39.8mg/kWh for natural gas and 80mg/kWh for LPG.

30, 40 and 60kW models must have a Seasonal Space Heating Energy Efficiency of A.

APPROVALS

The boiler must be tested and certified to EN 483, EN 677, PREN 15420, BS EN 15502, BS EN 656, BS EN 55014-1 and BS EN 55014-2 for use with Natural Gas. Boilers are certified to meet the requirements of the EC Gas Appliance Directive, Boiler Efficiency Directive, EMC and Low Voltage Directive.

The manufacturer must be ISO 9001 accredited.

SPECIFICATION

- The 30kW boiler will be capable of flow rates for common systems using either 11°C, 15°C, 20°C or 25°C temperature differentials.
- The 40, 60 and 80kW boiler will be capable of flow rates for common systems using either 11°C, 15°C, 20°C, 25°C or 30°C temperature differentials.
- The 100kW boiler will be capable of flow rates for common systems using either 15°C, 20°C, 25°C or 30°C temperature differentials.
- The 120 and 150kW boiler will be capable of flow rates for common systems using either 20°C, 25°C or 30°C temperature differentials.

SOURCING

The condensing boiler must be manufactured or finally assembled in the United Kingdom.

CASCADE

The boiler must be configurable up to 6 boilers (max 900kW) in cascade using a prefabricated frame and header kit.

WARRANTY

The boiler must be available with a 5 year warranty.

SYSTEM TEMPERATURE DIFFERENTIALS

Flow rates for common systems using either 11°C, 15°C, 20°C, 25°C or 30°C temperature differentials are given in the table below.

BOILER	FLOW RATE (L/MIN)					HYDRAULIC RESISTANCE (MBAR)				
	11°C	15°C	20°C	25°C	30°C	11°C	15°C	20°C	25°C	30°C
Evomax 2 30 / 30P	39.1	28.7	21.5	17.9	N/A	425	225	127	89	N/A
Evomax 2 40 / 40P	52.1	38.2	28.7	23.9	19.1	875	405	225	163	100
Evomax 2 60 / 60P	78.2	57.3	43.0	35.9	28.7	435	180	83	57	30
Evomax 2 80 / 80P	104.2	76.4	57.3	47.8	38.2	750	420	180	125	70
Evomax 2 100 / 100P	N/A	95.6	71.7	59.8	47.8	N/A	315	134	97	60
Evomax 2 120 / 120P	N/A	N/A	86.0	71.7	57.3	N/A	N/A	218	149	80
Evomax 2 150	N/A	N/A	107.5	89.6	71.7	N/A	N/A	230	158	85

- 30kW boilers must operate with temperature differentials from 11°C to 25°C.
- 40, 60 and 80kW boilers must operate with temperature differentials from 11°C to 30°C.
- 100kW boilers must operate with temperature differentials from 15°C to 30°C.
- 120 and 150kW boilers must operate with temperature differentials from 20°C to 30°C.

CONTROL KITS

VARICAN MODULE MASTER & SLAVE KITS

Enables cascade control from Evomax 2 boiler controls.

EXTENSION MODULE KIT

Capable of managing 2 mixing circuits. Multiple modules can be used.

OPENTHERM ROOM CONTROL KIT

Timed control of central heating via OPENTHERM.

ROOM SENSOR KIT

Used with Extension Module Kit for CH control

TANK SENSOR KIT

Provides DHW temperature control. Also for use with Extension Module Kit.

OUTSIDE SENSOR KIT

Provides weather compensation directly or with Extension Module Kit.

HEADER FLOW TANK IMMERSION SENSOR KIT

Ensures boiler provides correct temperature to water in header via immersed sensor

HEADER FLOW TANK STRAP ON SENSOR KIT

Ensures boiler provides correct temperature to water in header via external sensor

SAFETY INTERLOCK KIT

Provides boiler shut down via an external signal.

FLUE SYSTEMS

A comprehensive range of flue kits are available from Ideal Heating including horizontal and vertical concentric and open flue options.

For horizontal flues: this is the distance from the flue outlet centre line on the boiler to the outside wall.

For vertical flue: this is the distance from the top of the boiler case to the aperture in the weather collar. If elbows are to be used, then the equivalent length of that fitting must be subtracted from the maximum flue extensions allowed for that flue option.

Note: Horizontal terminal resistance includes 1 x 90° elbow.

When installing Evomax 2 boilers with concentric flue (horizontally or vertically) the Ideal commercial flue system must be used.

The resistance of flue components, together with the maximum flue resistance each boiler can work against, may be used to calculate the total flue resistance of the system, and to determine if they are acceptable to run on the boiler.

Multiple boilers may be installed with a common flue header.

The flue system should be designed and supplied by a specialist flue company. BS 6644 and IGEN UP10 provide guidance on design and the drainage of condensate from flue stack and headers. Condensate from a flue stack and header must be collected and drained before entering the boiler.

For Ventilation requirements, please refer to the Installation Manual.

EVOMAX 2 CASCADE

30 - 900kW



Cascade control



EVOMAX 2 CASCADE Frame & Header Kits

For installations requiring more output delivered in a flexible way, up to 6 Evomax 2 boilers can be installed in a cascade. An output of up to 900kW is possible with this modular option which is available in both Inline (Standard and Low Height) and Back to Back arrangements.

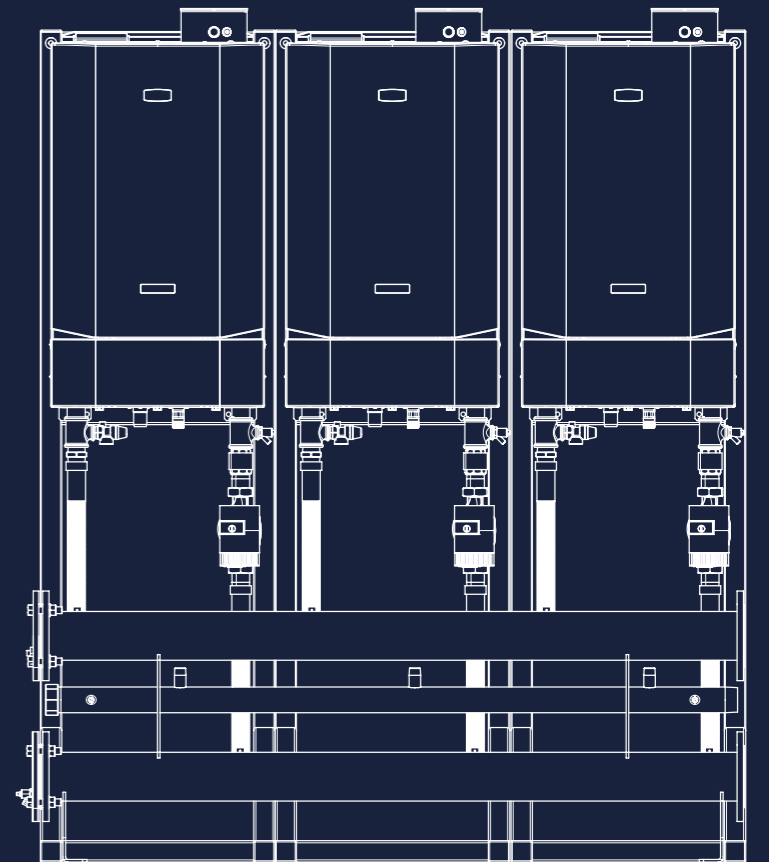

CHOOSING WHAT YOU NEED IS STRAIGHTFORWARD:

Choose Frames: select Standard or Low Height Frames, or mount on a wall

Choose a Header: select an Inline or Back to Back configuration for the total number of boilers in the cascade

Choose Hydraulic Separation: select Plate Heat Exchanger, Magnetic Low Loss Header or Low Loss Header

Choose Pumps: select the relevant pump for your cascade

Choose Insulation: select the insulation for a Header, Separation and Pumps

A few things to bear in mind:

- A Standard Height Inline or Back to Back cascade can be for up to 6 boilers
- A Low Height Inline cascade can be for up to 4 boilers
- 1 Standard Height Frame required for each boiler in the cascade
- 1 pump required for each boiler in the cascade

The wide range of options available are detailed on the pages overleaf. Alternatively, use our online Evomax 2 Cascade Configurator tool to compile a complete list of accessories for your cascade:

[idealcommercialboilers.com/evomax2-cascade-configurator](https://www.idealcommercialboilers.com/evomax2-cascade-configurator)

EVOMAX 2

Cascade Accessories

CHOOSE A FRAME KIT
Standard Height Up to 6 boilers 206970 1 frame required per boiler i.e. a 6 boiler cascade requires 6 frames
Low Height Inline Up to 4 boilers Included with Low Height Header Kit

Boilers not included with Frame or Header Kits; please remember to add them to your order.

EVOMAX2 PHEX PACKAGE
234562

A complete package to allow installation of single boilers with hydraulic separation from the secondary system using a brazed plate stainless steel plate heat exchanger. The boiler side of the package includes expansion vessel, pressure gauge, pressure relief valve, filling point and drain connection. Suitable for all Evomax2 boiler models with standard operating temperatures of 85/65°C boiler side and 75/55°C secondary side. Please contact your local sales representative to discuss other operating temperature profiles.

A complete package requires an Evomax2 boiler and boiler pump to be added.

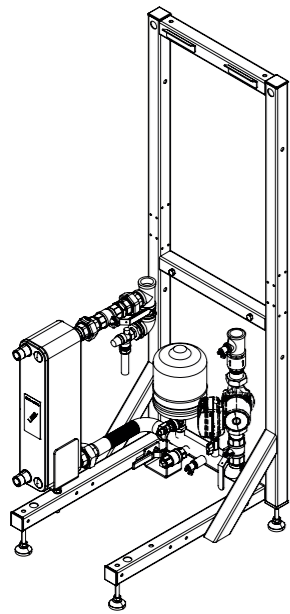

CHOOSE A HEADER KIT
Standard Height Frame, Inline boilers 2 boilers, 30 - 100kW (DN80) for PHEX & LLH 219542 2 boilers, 120 & 150kW (DN100) for PHEX & LLH 219547 3 boilers, 30 - 100kW (DN80) for PHEX & LLH 219543 3 boilers, 120 & 150kW (DN100) for PHEX & LLH 219548 4 boilers, 30 - 150kW (DN100) for PHEX & LLH 219549 5 boilers, 30 - 100kW (DN100) for PHEX & LLH 5 boilers, 120 & 150kW (DN100), PHEX 219545 5 boilers, 120 & 150kW (DN150) for LLH ONLY 219550 6 boilers, 30 - 150kW (DN100) for PHEX 6 boilers, 30 - 100kW (DN100) for LLH 219546 6 boilers, 120 & 150kW (DN150) for LLH ONLY 219551
Standard Height Frame, Back to Back boilers 2 boilers, 30 - 150kW (DN80) for PHEX & LLH 219555 3 boilers, 30 - 150kW (DN80) for PHEX & LLH 219556 4 boilers, 30 - 150kW (DN100) for PHEX & LLH 219557 5 boilers, 30 - 150kW (DN100) for PHEX & LLH 219558 6 boilers, 30 - 150kW (DN100) for PHEX ONLY 222397 6 boilers, 30 - 150kW (DN150) for LLH ONLY 219559
Low Height Frame, Inline boiler 1 boiler, 30 - 150kW for (DN50) for PHEX & LLH 221127 2 boilers, 30 - 150kW (DN65) for PHEX & LLH 221128 3 boilers, 30 - 150kW (DN80) for PHEX & LLH 221129 4 boilers, 30 - 150kW (DN100) for PHEX & LLH 219561

CHOOSE HYDRAULIC SEPARATION
Low Loss / Mixing Header DN50 - 209394 DN65 - 209395 DN80 - 219552 DN100 - 219553 DN150 - 219554
Magnetic Low Loss / Mixing Header (MLLH) DN50 - 222191 DN65 - 222192 DN80 - 222193 DN100 - 222194
Plate Heat Exchanger Up to 60kW nominal output (DN50) 222219 Insulation Kit - 234443 Up to 60kW nominal output (DN65) 222993 Insulation Kit - 234443 Up to 60kW nominal output (DN80) 222220 Insulation Kit - 234444 Up to 150kW nominal output (DN50) 222221 Insulation Kit - 234445 Up to 150kW nominal output (DN65) 222994 Insulation Kit - 234445 Up to 150kW nominal output (DN80) 222222 Insulation Kit - 234446 Up to 300kW nominal output (DN65) 222223 Insulation Kit - 234447 Up to 300kW nominal output (DN80) 222225 Insulation Kit - 234447 Up to 300kW nominal output (DN100) 222995 Insulation Kit - 234448 Up to 450kW nominal output (DN80) 222226 Insulation Kit - 234449
Plate Heat Exchanger Up to 450kW nominal output (DN100) 222996 Insulation Kit - 234449 Up to 600kW nominal output (DN100) 222227 Insulation Kit - 234450 Up to 750kW nominal output (DN100) 222228 Insulation Kit - 234451 Up to 900kW nominal output (DN100) 222229 Insulation Kit - 234454

CHOOSE PUMPS
Low Loss / Mixing Header Chosen Grundfos UPML (M)LLH Pump Kit 222659
Plate Heat Exchanger Chosen Grundfos UPMXXL PHEX Pump Kit 222660 1 pump required per boiler i.e. a 6 boiler cascade requires 6 pumps
No Separation Chosen Grundfos UPML Pump Kit 222659

If using a Low Loss Header or Plate Heat Exchanger not from Ideal Heating, please use the pump recommended by the manufacturer

CHOOSE INSULATION
For Standard Height Header Kits DN80/100 Starter Kit 222960 DN80/100 Continuation Kit 222961 DN80/100 Joined Header Kit 222962
For Low Height Header Kits DN50 Starter Kit 223032 DN65 Starter Kit 223035 DN65 Continuation Kit 223036 DN80/100 Starter Kit 223038 DN80/100 Continuation Kit 223039 DN80/100 Joined Header Kit 223040
For Low Loss and Magnetic Low Loss Header DN50 (M)LLH Insulation Kit 222963 DN65 (M)LLH Insulation Kit 222964 DN80/100 (M)LLH Insulation Kit 222965
For Grundfos UPML (M)LLH Pump Kit (M)LLH Pump Insulation Kit 222894

STANDARD HEIGHT INLINE CASCADES

2 X EVOMAX 2

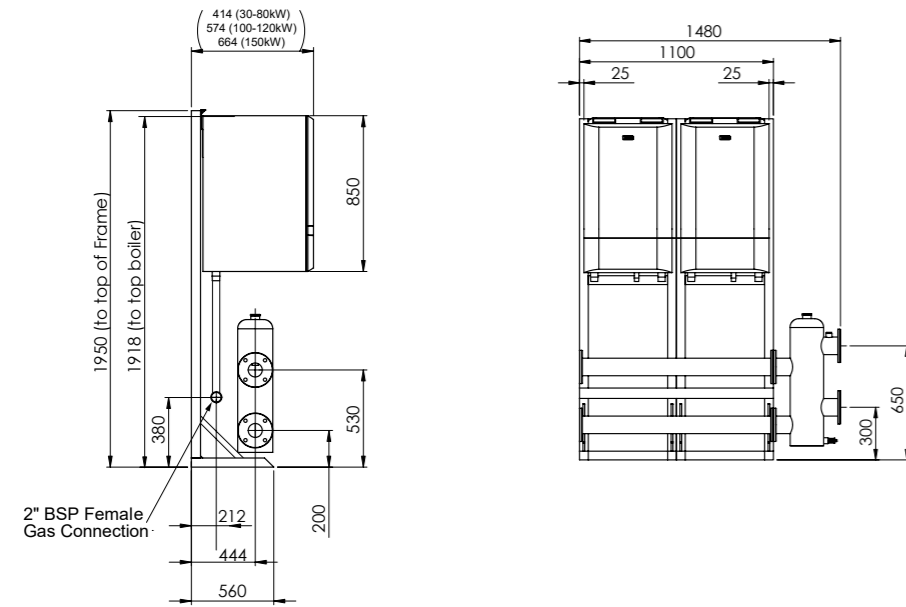

UIN	DN FLANGE SIZE	SUITABLE FOR
219542	DN80	2 x Evomax 2 boilers, 30 – 100kW with PHEX or (M)LLH separation
219547	DN100	2 x Evomax 2 boilers, 120 & 150kW with PHEX or (M)LLH separation

3 X EVOMAX 2

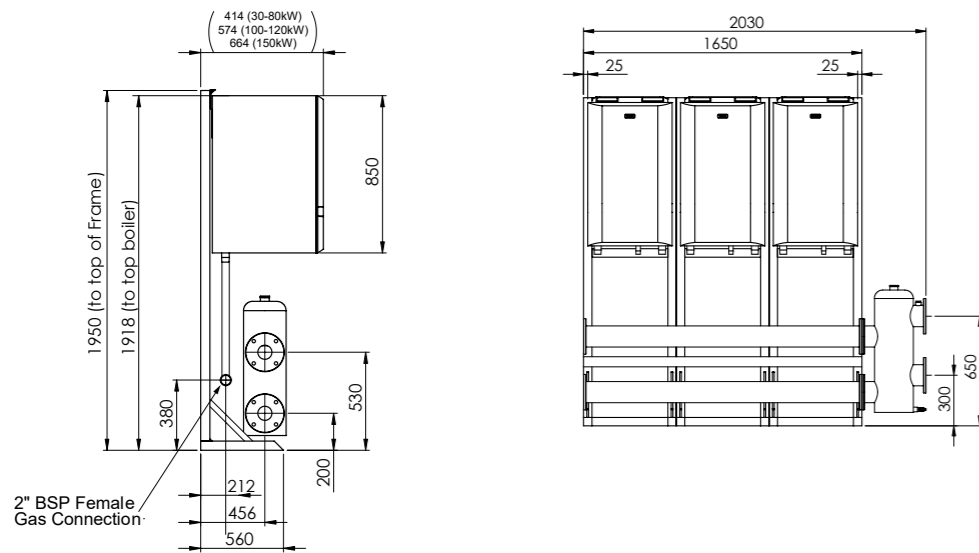

UIN	DN FLANGE SIZE	SUITABLE FOR
219543	DN80	3 x Evomax 2 boilers, 30 – 100kW with PHEX or (M)LLH separation
219547	DN100	3 x Evomax 2 boilers, 120 & 150kW with PHEX or (M)LLH separation

STANDARD HEIGHT INLINE CASCADES

4 X EVOMAX 2

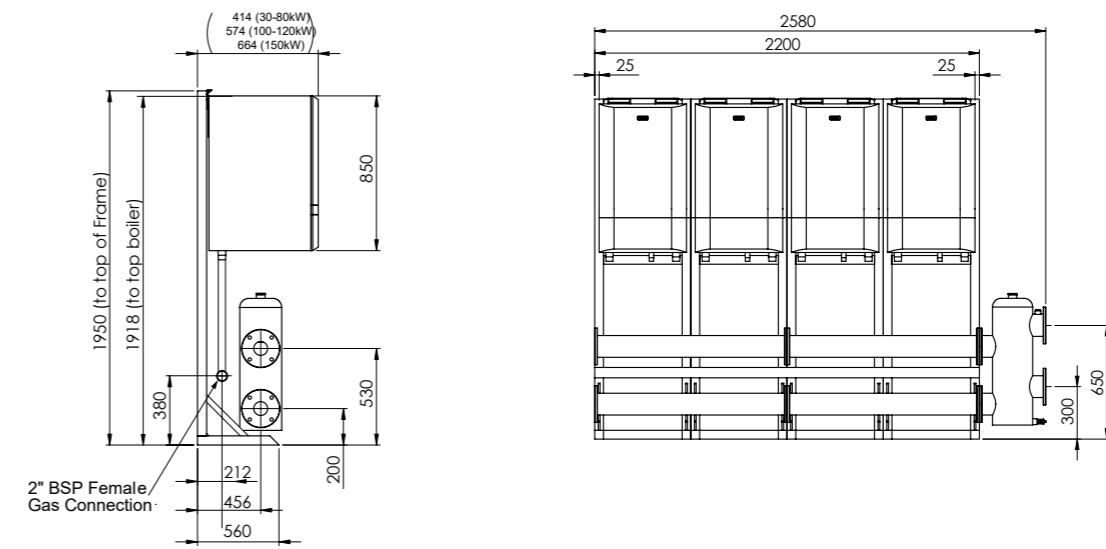

UIN	DN FLANGE SIZE	SUITABLE FOR
219549	DN100	4 x Evomax 2 boilers, 30 – 150kW with PHEX or (M)LLH separation

5 X EVOMAX 2

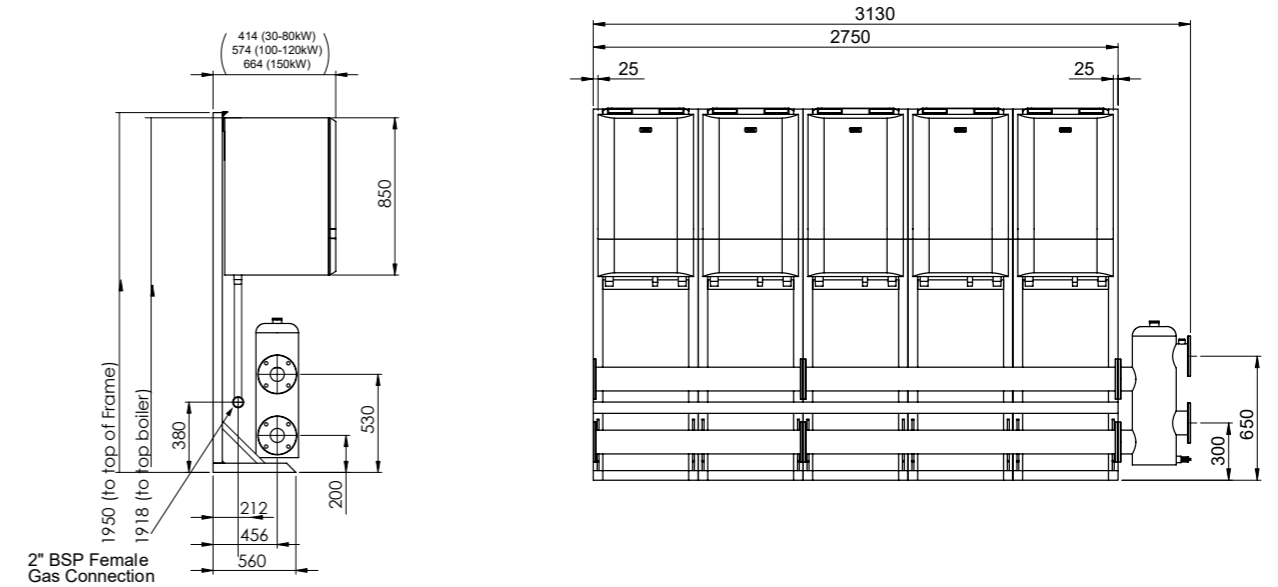

UIN	DN FLANGE SIZE	SUITABLE FOR
219545	DN100	5 x Evomax 2 boilers, 30 – 150kW with PHEX separation 5 x Evomax 2 boilers, 30 – 100kW with (M)LLH separation
219547	DN150	5 x Evomax 2 boilers, 120 & 150kW with LLH separation

STANDARD HEIGHT INLINE CASCADES

6 X EVOMAX 2

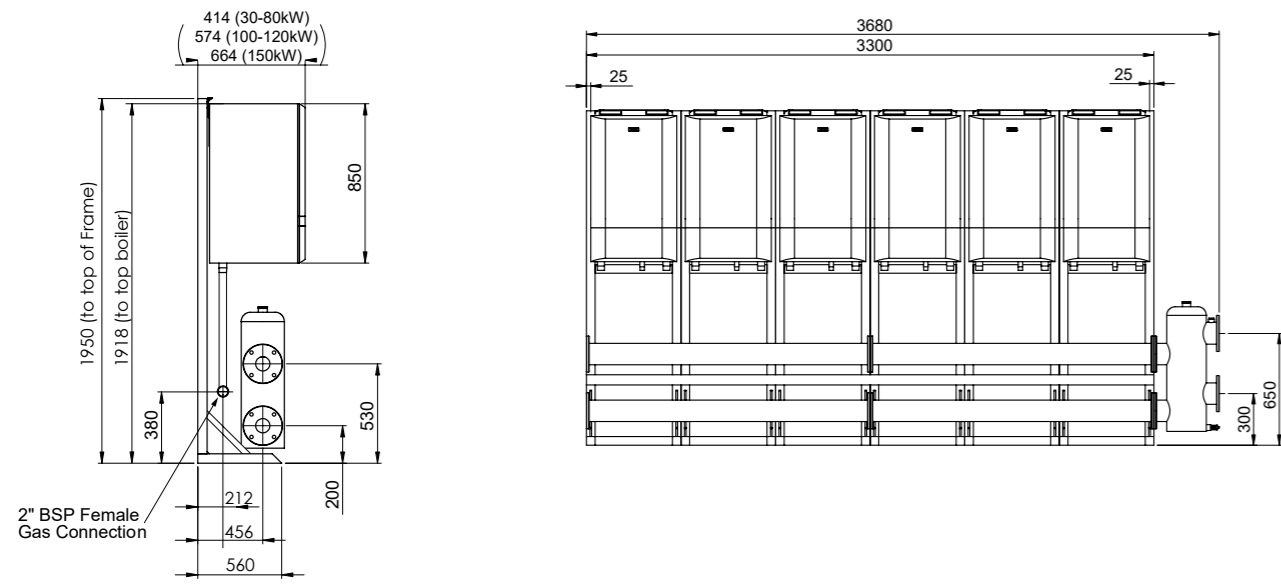

UIN	DN FLANGE SIZE	SUITABLE FOR
219546	DN100	6 x Evomax 2 boilers, 30 – 150kW with PHEX separation 6 x Evomax 2 boilers, 30 – 100kW with (M)LLH separation
219551	DN150	6 x Evomax 2 boilers, 120 & 150kW with LLH separation

LOW HEIGHT INLINE CASCADES

1 X EVOMAX 2

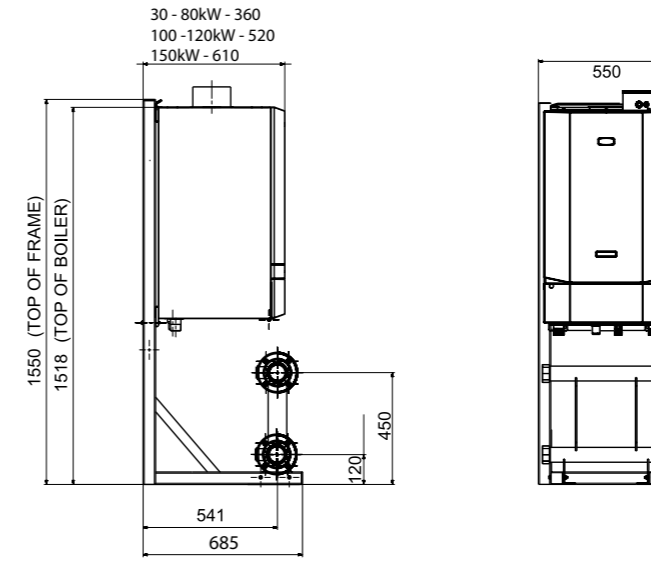

UIN	DN FLANGE SIZE	SUITABLE FOR
221127	DN50	1 x Evomax 2 boilers, 30 – 150kW with PHEX or (M)LLH separation

STANDARD HEIGHT

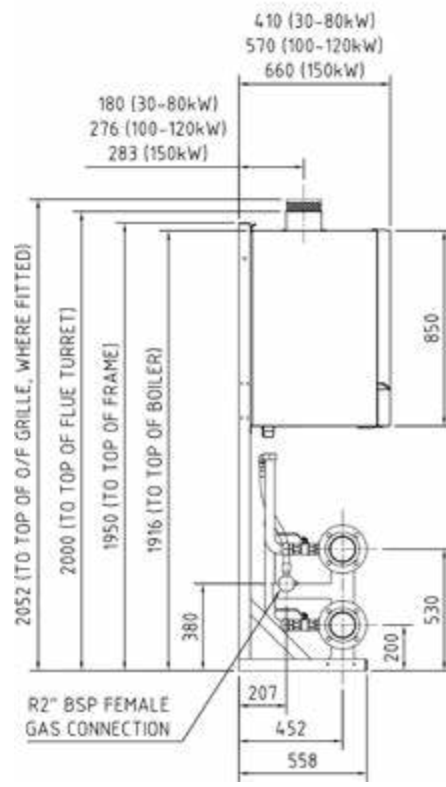

LOW HEIGHT

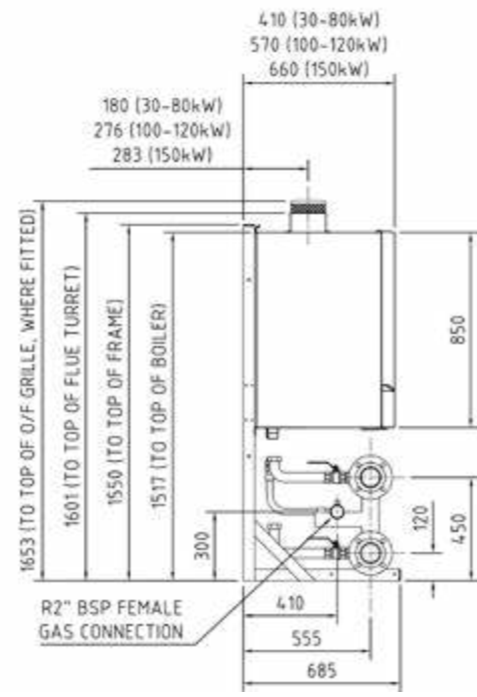

2 X EVOMAX 2

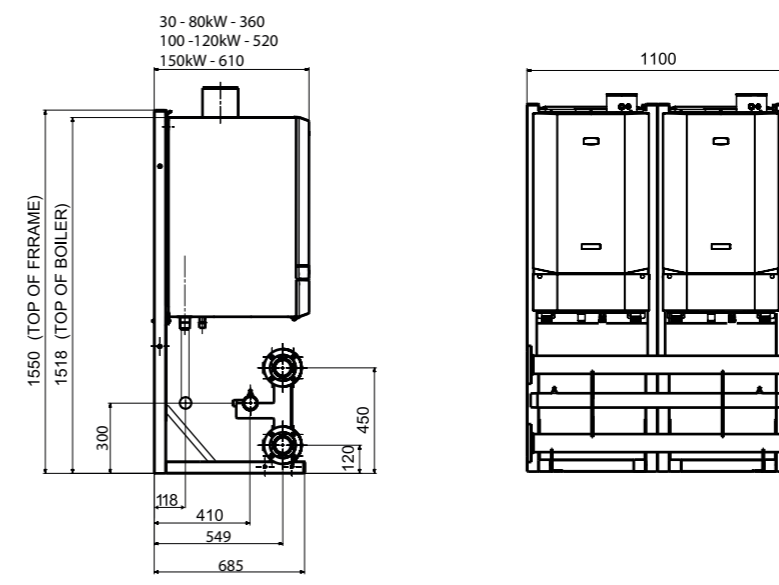

UIN	DN FLANGE SIZE	SUITABLE FOR
221128	DN65	2 x Evomax 2 boilers, 30 – 150kW with PHEX or (M)LLH separation

LOW HEIGHT INLINE CASCADES

3 X EVOMAX 2

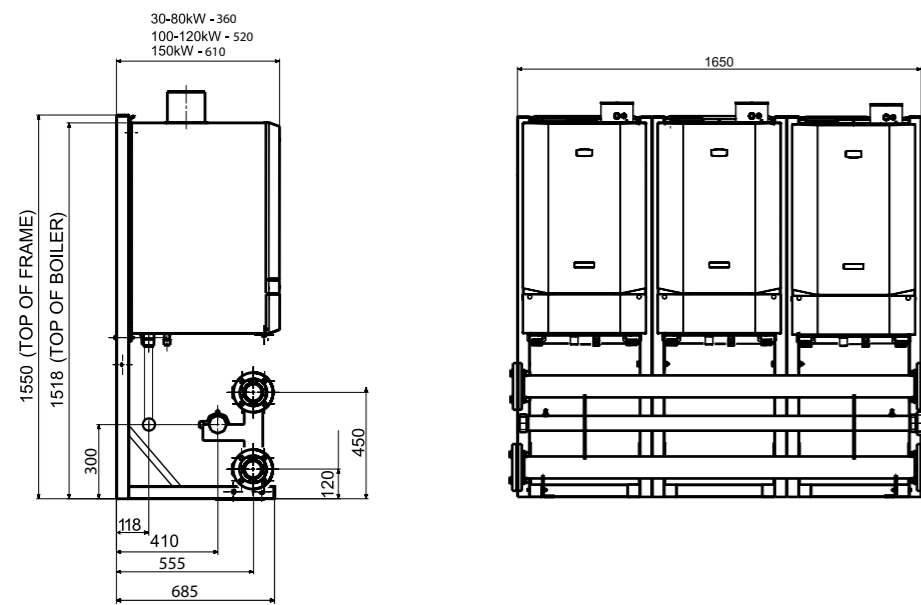

UIN	DN FLANGE SIZE	SUITABLE FOR
221129	DN80	3 x Evomax 2 boilers, 30 – 150kW with PHEX or (M)LLH separation

4 X EVOMAX 2

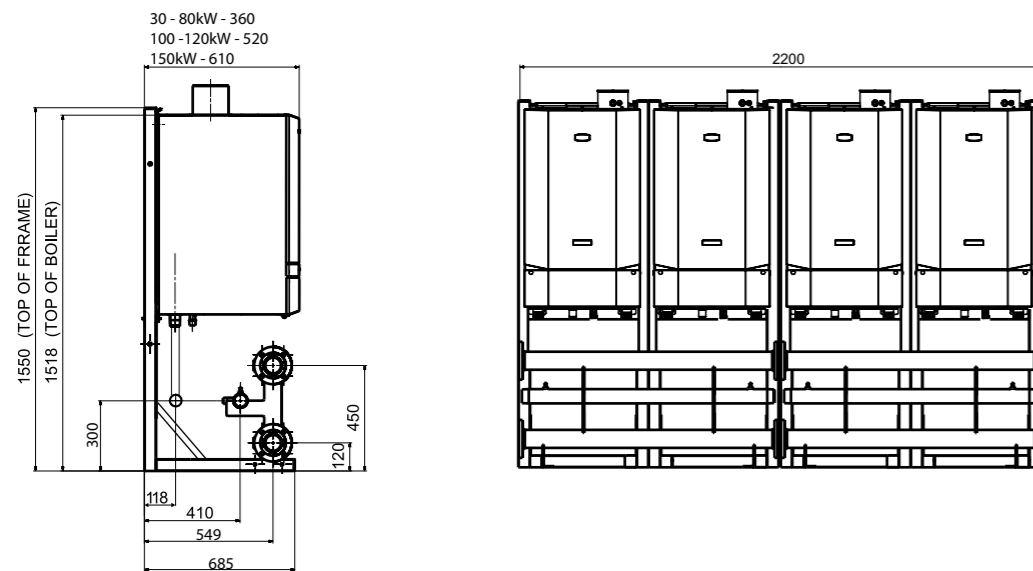

UIN	DN FLANGE SIZE	SUITABLE FOR
219561	DN100	4 x Evomax 2 boilers, 30 – 150kW with PHEX or (M)LLH separation

Note: all flanges on boiler headers are PN6

HYDRAULIC SEPARATION

Ideal Heating offer various solutions to hydraulic separation

PLATE HEAT EXCHANGER



Covering outputs of 60, 150, 300, 450, 600, 750 and 900kW. Brazed Plate Heat Exchangers ensure optimum heat transfer efficiency and low resistance within a compact footprint. To be used with Ideal Heating Frame and Header kits.

FEATURES & BENEFITS

- Compact design
- No gaskets
- Low maintenance and self-cleaning
- All units are pressure tested
- To be used with Ideal Heating Frame and Header kits
- Ensures optimal heat transfer efficiency and pressure resistance
- Separates system water from the boiler
- Ensures the highest performance for longest possible service life

UP TO 60kW NOMINAL OUTPUT PLATE HEAT EXCHANGER

UIN	DN FLANGE SIZE
222219	DN50
222993	DN65
222220	DN80

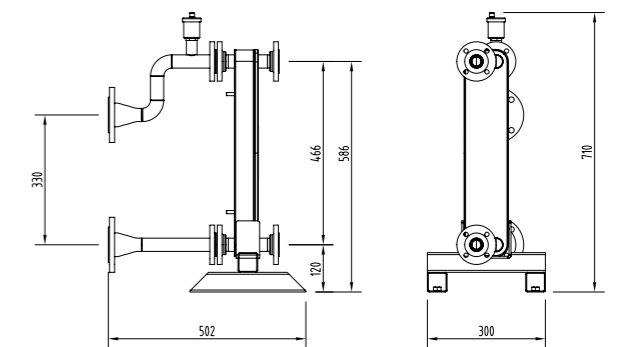

222219 DN50

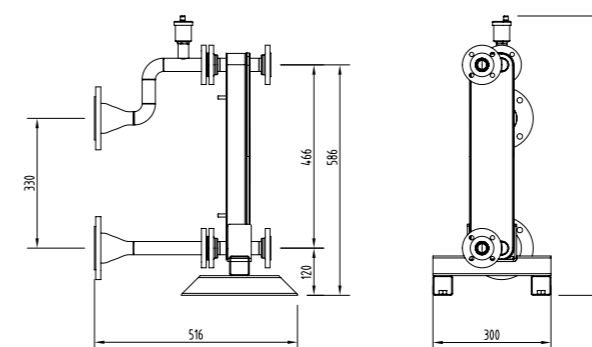

222993 DN65

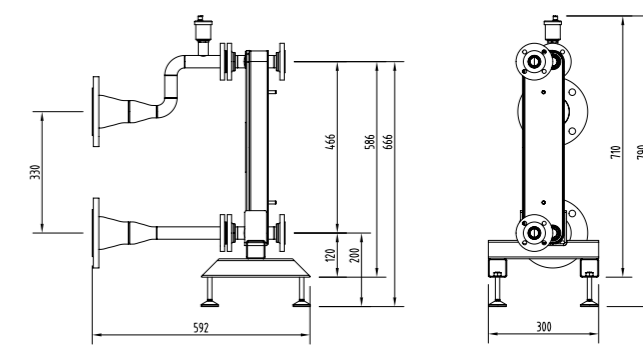

222220 DN80

UP TO 150KW NOMINAL OUTPUT
PLATE HEAT EXCHANGER

UIN	DN FLANGE SIZE
222221	DN50
222994	DN65
222222	DN80

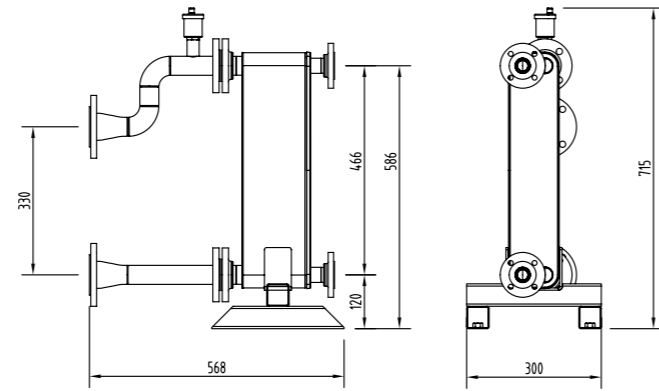

222221 DN50

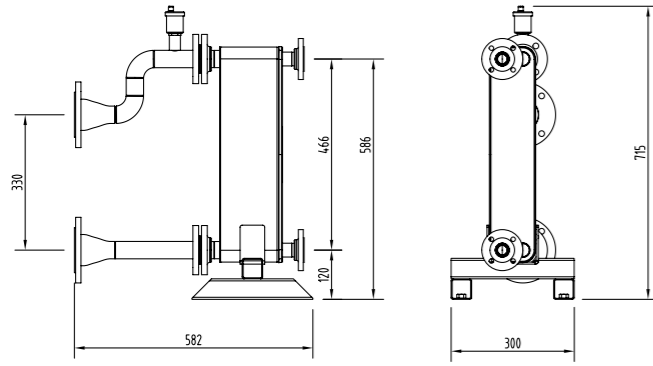

222222 DN80

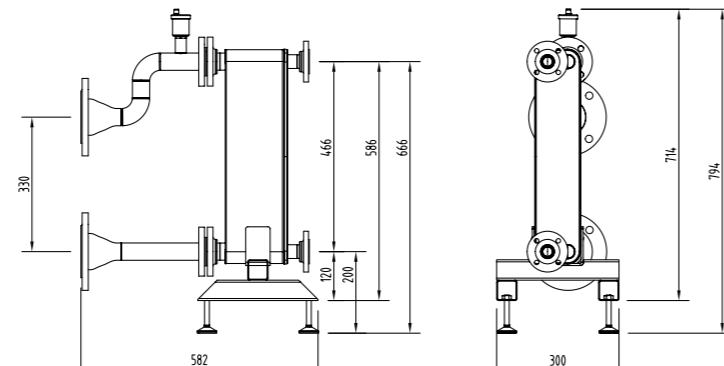

222994 DN65

UIN	DN FLANGE SIZE
222226	DN80
222996	DN100

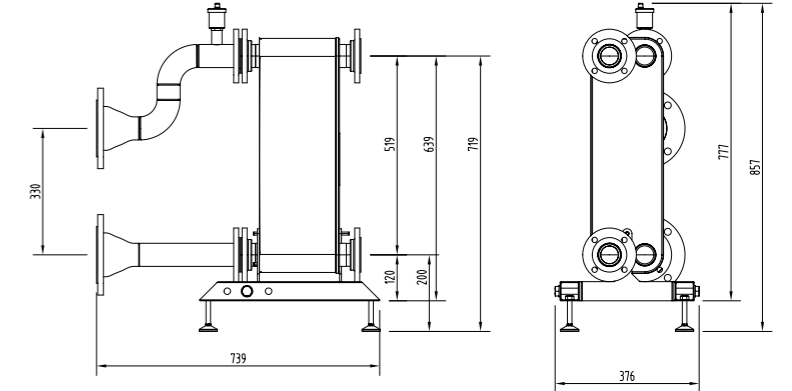

222226 DN80

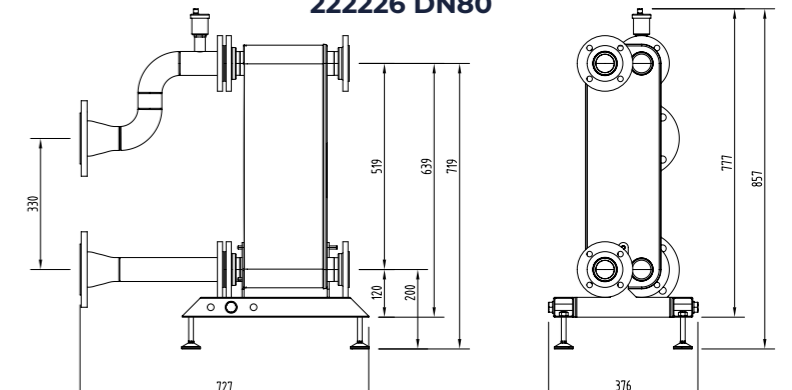

222996 DN100

UP TO 300KW NOMINAL OUTPUT
PLATE HEAT EXCHANGER

UIN	DN FLANGE SIZE
222223	DN65
222225	DN80
222995	DN100

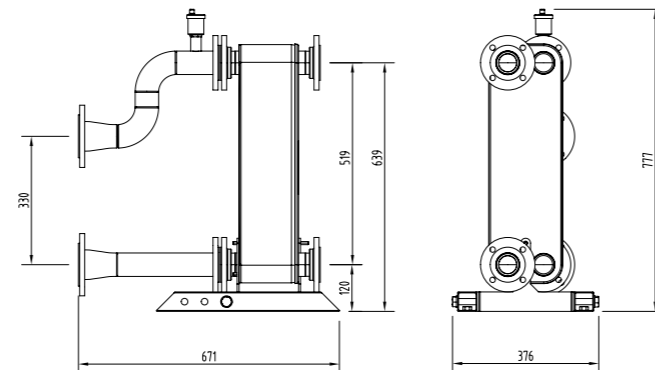

222223 DN65

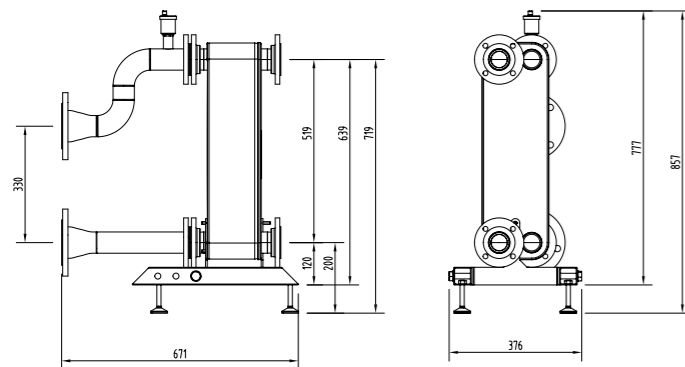

222225 DN80

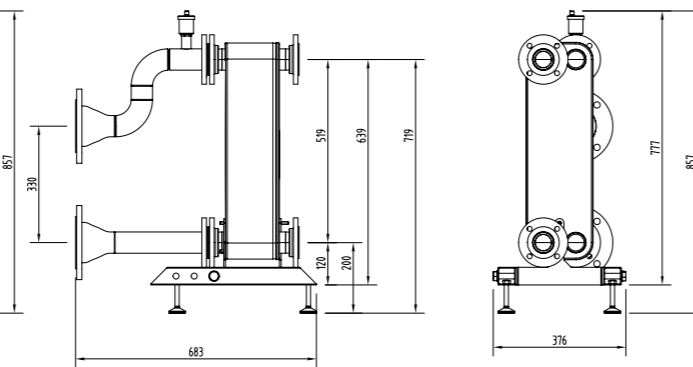

222995 DN100

UIN	DN FLANGE SIZE
222227	DN100

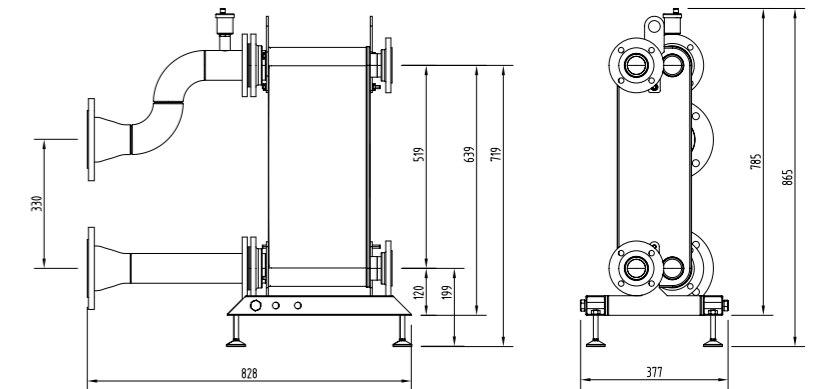

222227 DN100

UP TO 750KW NOMINAL OUTPUT
PLATE HEAT EXCHANGER

UIN	DN FLANGE SIZE
222228	DN100

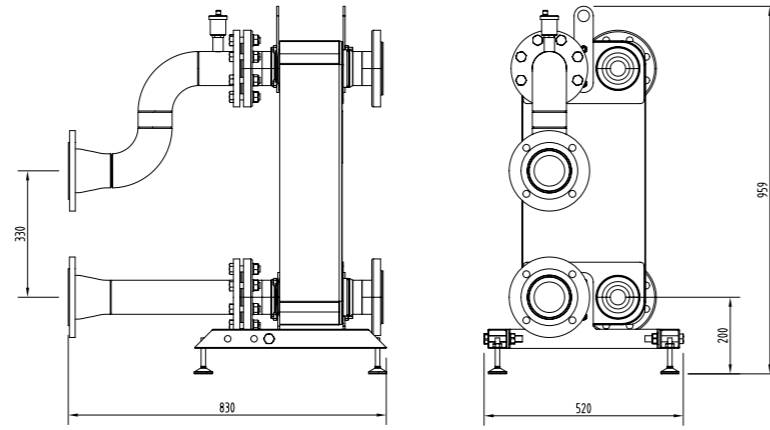

222228 DN100

UP TO 900KW NOMINAL OUTPUT
PLATE HEAT EXCHANGER

UIN	DN FLANGE SIZE
222229	DN100

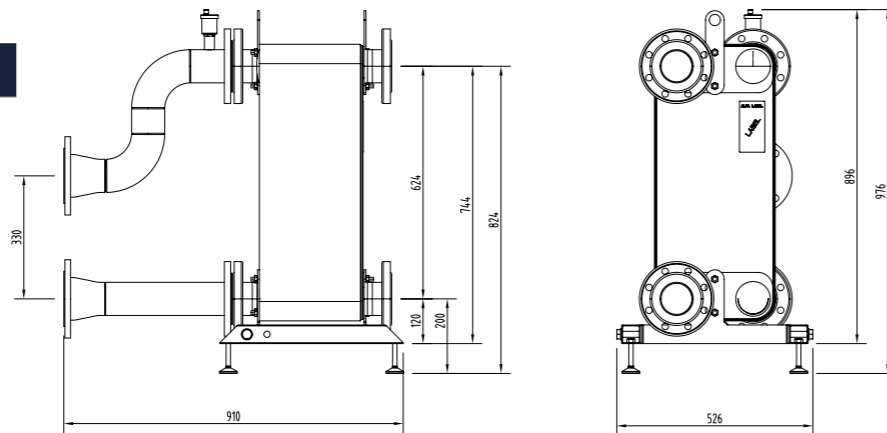

222229 DN100

Note: refer to PHEX spec sheets for details of secondary flange sizes and PN ratings.



LOW LOSS HEADER AND MAGNETIC LOW LOSS HEADER

Providing an alternative approach to hydraulic separation, Low Loss Headers (LLH) are available in various sizes to suit the accompanying Header kits. There is also the option of a Magnetic Low Loss Header (MLLH), combining the benefits of a low loss header and a magnetic filter.

LOW LOSS HEADER

UIN	DN FLANGE SIZE
209394	DN50
209395	DN65
219552	DN80
219553	DN100
219554	DN150

MAGNETIC LOW LOSS HEADER

UIN	DN FLANGE SIZE
222191	DN50
222192	DN65
222193	DN80
222194	DN100

Note: all low loss and magnetic low loss headers use PN6 flanges

PUMPS

To ensure your Evomax 2 Cascade works correctly, it is vital to fit the correct pumps. One pump is required per boiler in the Cascade.

SEPARATION CHOSEN	UIN	PUMP TYPE
(M)LLH or none	222659	Grundfos UPML (M)LLH Pump Kit
PHEX	222660	Grundfos UPMXXL PHEX Pump Kit

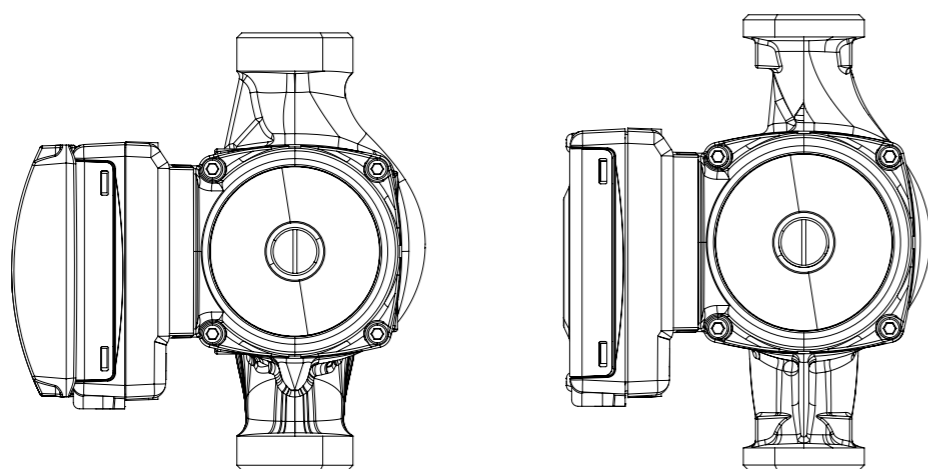

Note: pumps with screwed connections are G1.1/2" x 180mm.

INSULATION

Header kits and Low Loss Headers can be insulated using our robust expanded polypropylene modular insulation range. Insulation is also available for 222659 Grundfos UPML (M)LLH Pump Kit.

The number of boilers in your Cascade will determine the type and number of kits required.

DN100 STANDARD HEIGHT IN-LINE HEADER



STANDARD HEIGHT INSULATION STARTER KIT + STANDARD HEIGHT INSULATION CONTINUATION KIT + STANDARD HEIGHT INSULATION CONTINUATION KIT

DN80 LOW HEIGHT 4 IN-LINE HEADER



LOW HEIGHT INSULATION STARTER KIT + LOW HEIGHT INSULATION CONTINUATION KIT + LOW HEIGHT INSULATION JOINED HEADER KIT + LOW HEIGHT INSULATION CONTINUATION KIT

INSULATION FOR STANDARD HEIGHT INLINE AND BACK TO BACK HEADER KITS

UIN	DESCRIPTION	2 BOILER CASCADE	3 BOILER CASCADE	4 BOILER CASCADE	5 BOILER CASCADE	6 BOILER CASCADE
222960	Standard Height Insulation Starter Kit	1	1	1	1	1
222961	Standard Height Insulation Continuation Kit	1	2	2	3	4
222962	Standard Height Insulation Joined Header Kit	-	-	1	1	1

INSULATION FOR LOW HEIGHT HEADER KITS

UIN	DESCRIPTION	1 BOILER CASCADE	2 BOILER CASCADE	3 BOILER CASCADE	4 BOILER CASCADE
223032	Standard Height Insulation Starter Kit DN50	1	-	-	-
223035	Standard Height Insulation Starter Kit DN65	-	1	-	-
223038	Standard Height Insulation Starter Kit DN80 & DN100	-	-	1	1
223036	Standard Height Insulation Continuation Kit DN65	-	1	-	-
223039	Standard Height Insulation Continuation Kit DN80 & DN100	-	-	2	2
223040	Standard Height Insulation Joined Header Kit DN80 & DN100	-	-	-	1

INSULATION FOR LOW LOSS HEADER AND MAGNETIC LOW LOSS HEADER

UIN	DESCRIPTION
222963	DN50 (M)LLH Insulation Kit
222964	DN65 (M)LLH Insulation Kit
222965	DN80/DN100 (M)LLH Insulation Kit

INSULATION FOR PUMPS

UIN	DESCRIPTION	1 BOILER CASCADE	2 BOILER CASCADE	3 BOILER CASCADE	4 BOILER CASCADE	5 BOILER CASCADE	6 BOILER CASCADE
223032	Grundfos UPML (M)LLH Insulation Kit	1	2	3	4	5	6



SYSTEM LAYOUT

TYPICAL SYSTEM BOILER LAYOUT

EVOMAX 2 FRAME & HEADER KIT C/W PLATE HEAT EXCHANGER

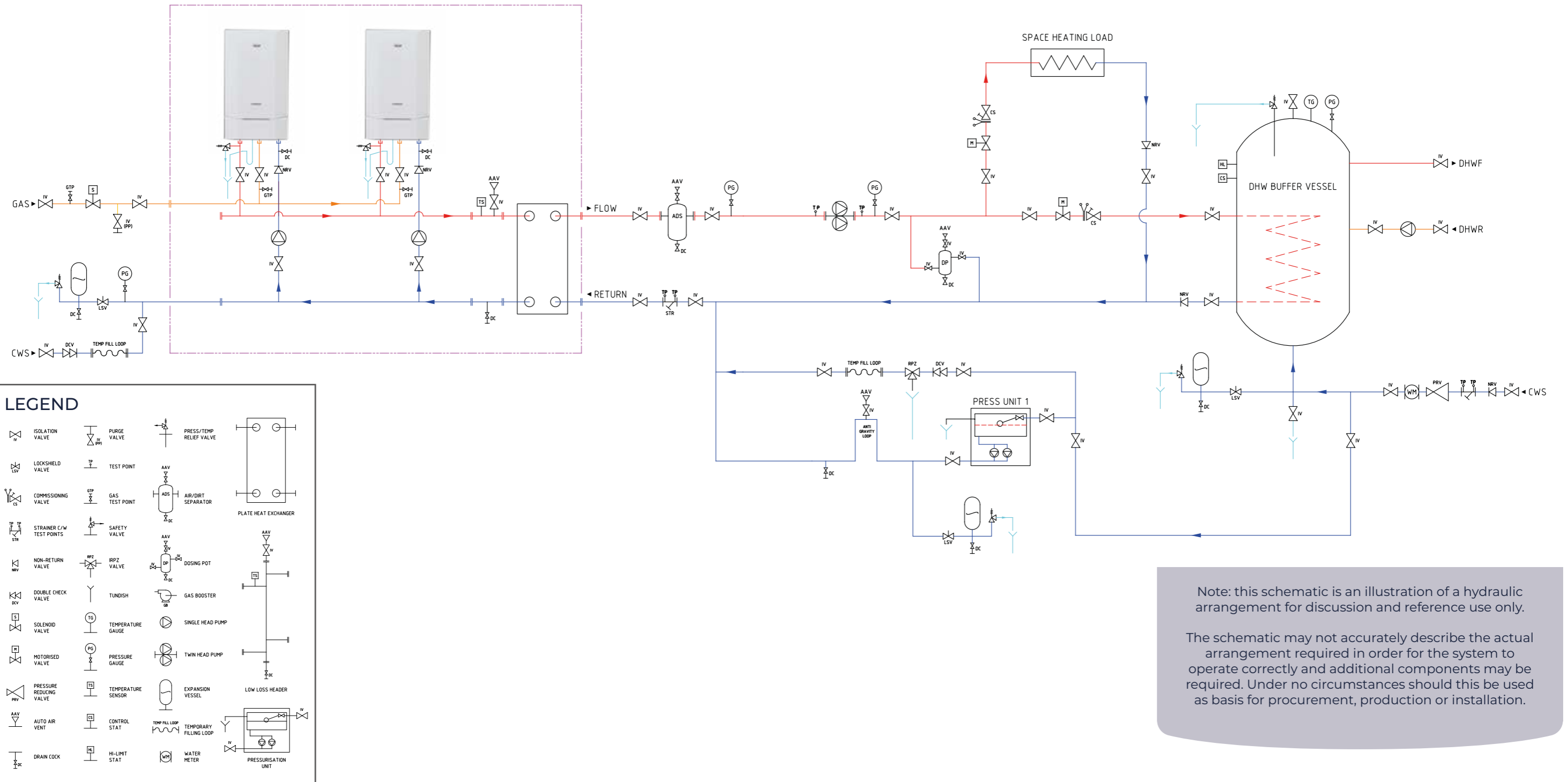

Note: this schematic is an illustration of a hydraulic arrangement for discussion and reference use only.

The schematic may not accurately describe the actual arrangement required in order for the system to operate correctly and additional components may be required. Under no circumstances should this be used as basis for procurement, production or installation.

EVOMAX 2 FLUE OPTIONS

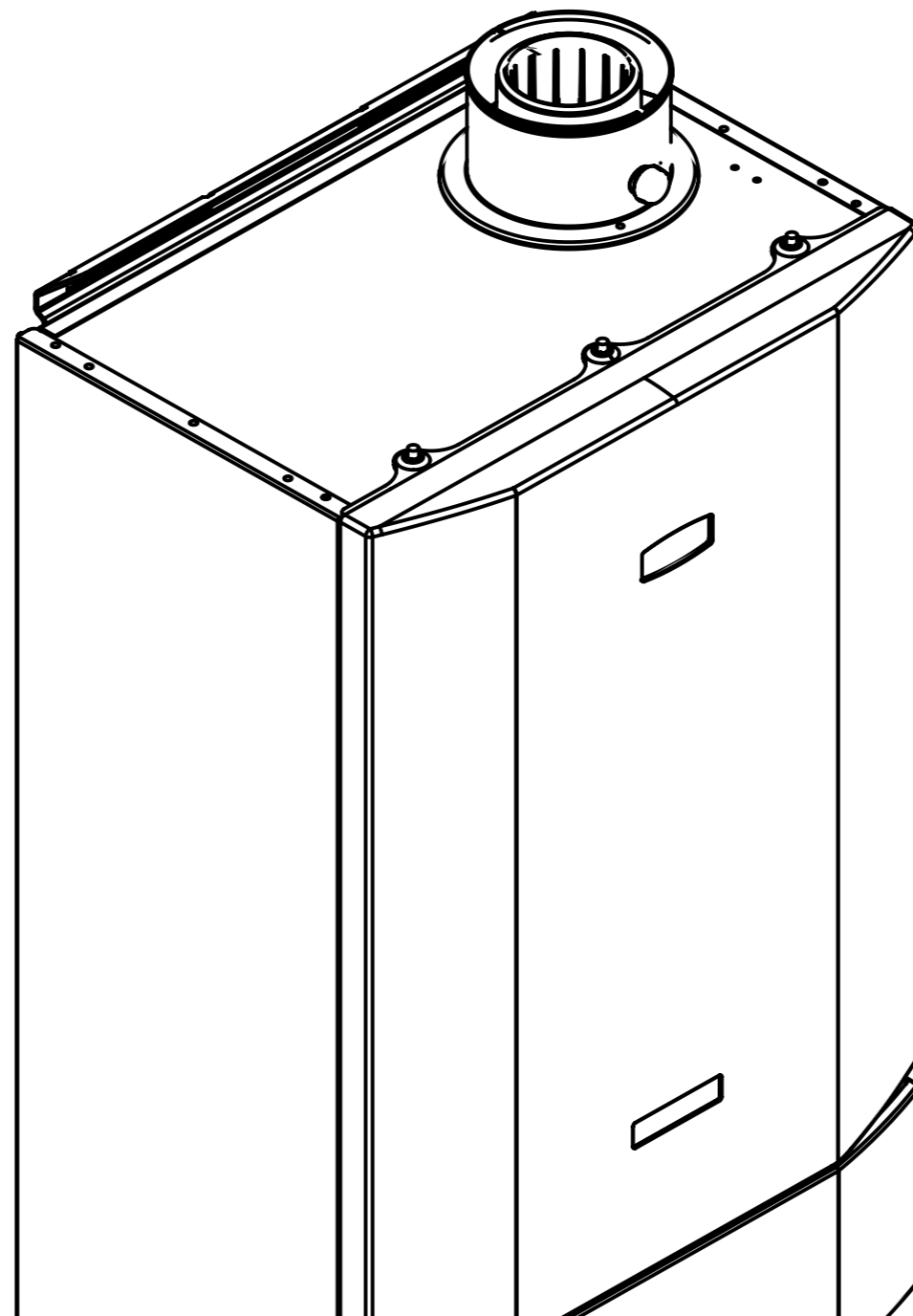
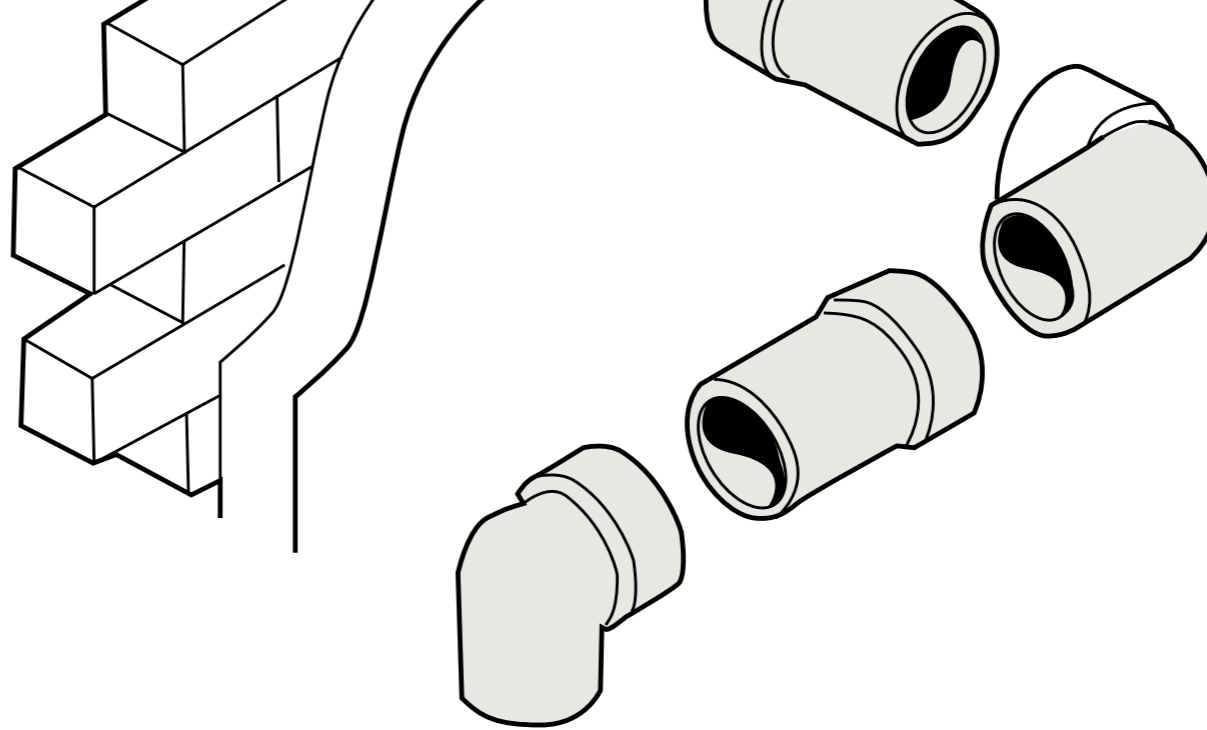

CONCENTRIC FLUE OPTIONS (C TYPE)

HORIZONTAL WALL FLUE KIT

EVOMAX 2 HORIZONTAL CONCENTRIC FLUE APPLICATION ~ MAXIMUM LENGTHS AND PRESSURE DIFFERENTIALS

Model	30/30P	40/40P	60/60P	80/80P	100/100P	120/120P	150
Max flue length (m)	33	30	17.5	10	10	9	6
Flue Size	80/125			100/150			
Wall flue kit No	220919			220921			

CONTENTS

- 90° elbow
- Terminal
- Locking collars (x2)
- Wall plates (x2)

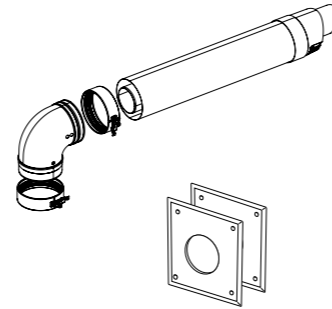

EVOMAX 2 60 & 80 HORIZONTAL CONCENTRIC FLUES OF LONGER LENGTHS (LARGER FLUE DIAMETER)

Model	60/60P	80/80P
Max flue length (m)	28	18
Flue Size	100/150	
Wall flue kit No	220920	

CONTENTS

- Increaser
- 90° elbow
- Terminal
- Locking collars (x2)
- Wall plates (x2)

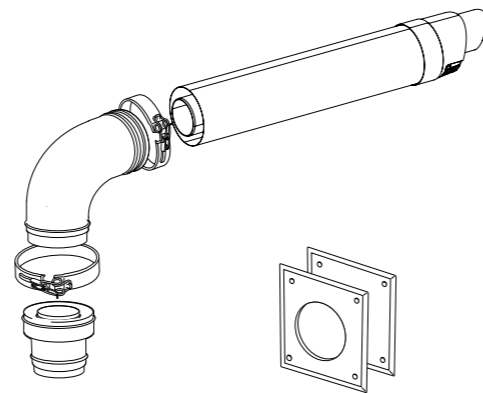

To comply with CE certification, Evomax boilers must be fitted with Ideal concentric flues (when using concentric flue type).

VERTICAL ROOF FLUE KIT

EVOMAX 2 VERTICAL CONCENTRIC FLUE APPLICATION ~ MAXIMUM LENGTHS AND PRESSURE DIFFERENTIALS

Model	30/30P	40/40P	60/60P	80/80P	100/100P	120/120P	150
Max flue length (m)	33	30	17.5	10	10	9	6
Flue Size	80/125			100/150			
Wall flue kit No	220915			220918			

CONTENTS

- Terminal
- Locking Collar
- Finishing plates (x2)
- Bracket

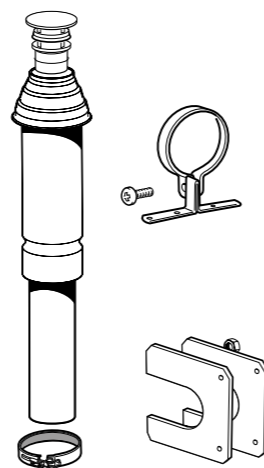

EVOMAX 2 60 & 80 VERTICAL CONCENTRIC FLUES OF LONGER LENGTH

Model	60/60P	80/80P
Max flue length (m)	28	18
Flue Size	100/150	
Wall flue kit No	220916	

CONTENTS

- Increaser
- Terminal
- Locking Collars (x2)
- Finishing plates (x2)
- Bracket

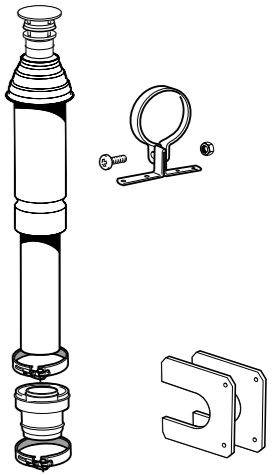

OPEN FLUE OPTIONS (B TYPE)

EVOMAX 2 VERTICAL CONCENTRIC FLUE APPLICATION ~ MAXIMUM LENGTHS AND PRESSURE DIFFERENTIALS

Model	30/30P	40/40P	60/60P	80/80P	100/100P	120/120P	150
Max flue length (m)	65	70	25	15.3	20	49	32
Max flue press diff (Pa)	180	227	146	312	220	473	332
Flue Size	80/125			100/150			
Wall flue kit No	221216 + 158771 + 158769			221218 + 158772 + 158770			

CONTENTS

- | | | |
|---------------------|-----------------|-------------------------|
| 221216 / 221218 | 158769 / 158770 | 158771 / 158772 |
| • Air inlet grille* | • Terminal | • Extension tube (x2)** |

* The air inlet grille must be fitted to all installations.

** At least 1 off extension tube MUST be used in the installation. This may be suitably cut to length if required.



FLUE KIT ACCESSORIES

FLUE KITS - CONCENTRIC	UIN
Vertical Roof Flue Kit 80/125 (30 - 80kW)	220915
Vertical Roof Flue Kit 100/150 (60 & 80kW)	220916
Vertical Roof Flue Kit 100/150 (100 - 150kW)	220918
Horizontal Wall Flue Kit 80/125 (30 - 80kW)	220919
Horizontal Wall Flue Kit 100/150 (60 & 80kW)	220920
Horizontal Wall Flue Kit 100/150 (100 & 120kW)	220921
Extension Kit 80/125	213261
Extension Kit 100/150	213262
Pitched Weather Collar 80/125	152609
Pitched Weather Collar 100/150	152610
Flat Weather Collar 80/125	152611
Flat Weather Collar 100/150	152612
90° Elbow 80/125 (single)	213259
90° Elbow 100/150 (single)	213263
90° Elbow 80/125 (Extended)	222004
90° Elbow 100/150 (Extended)	222005
45° Elbow 80/125 (single)	213260
45° Elbow 100/150 (single)	213258
Wall Bracket 125mm	202242
Wall Bracket 150mm	202243
Expander 80/125 - 100/150	222133
FLUE KITS - OPEN FLUE	UIN
Open Flue Kit 80	221216
Open Flue Kit 100	221218
Vertical Flue Terminal 80	158769
Vertical Flue Terminal 100	158770
Extension Pipes 80 (pair)	158771
Extension Pipes 100 (pair)	158772
90° Elbow 80 (single)	158773
90° Elbow 100 (single)	158774
45° Elbow 80 (pair)	158775
45° Elbow 100 (pair)	158776
Pitched Weather Collar 80 & 100	158779
Flat Weather Collar 80 & 100	152259
Increaser 80-100	152404

FLUE KITS - CONCENTRIC

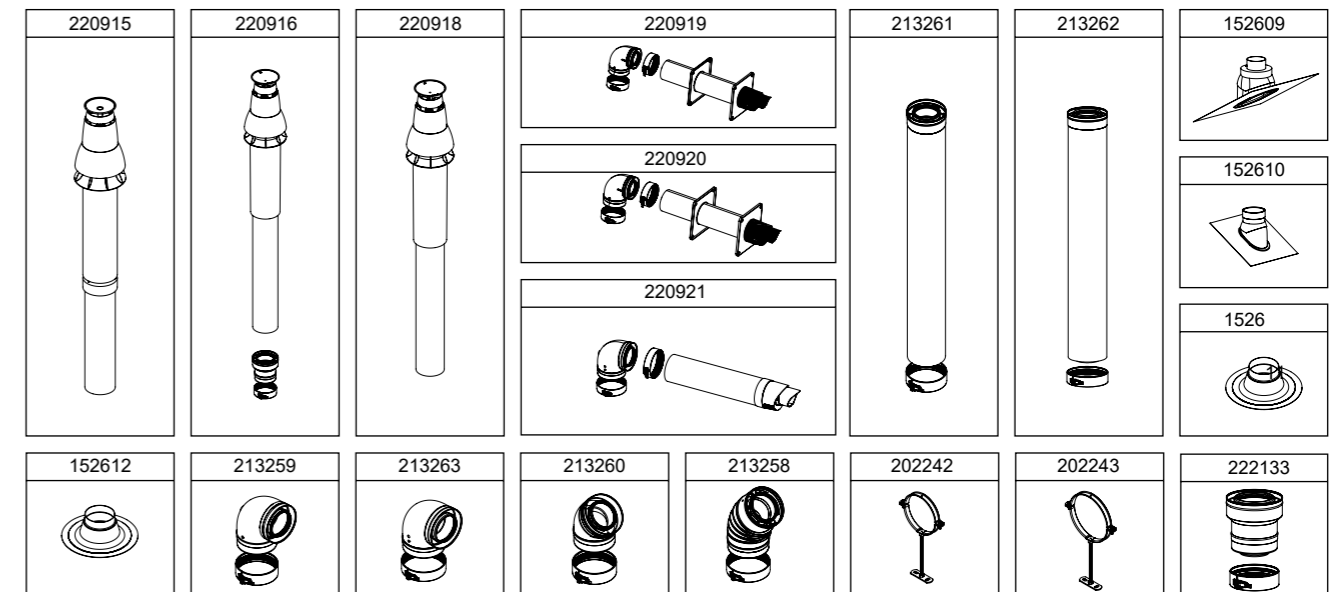

FLUE KITS - OPEN FLUE

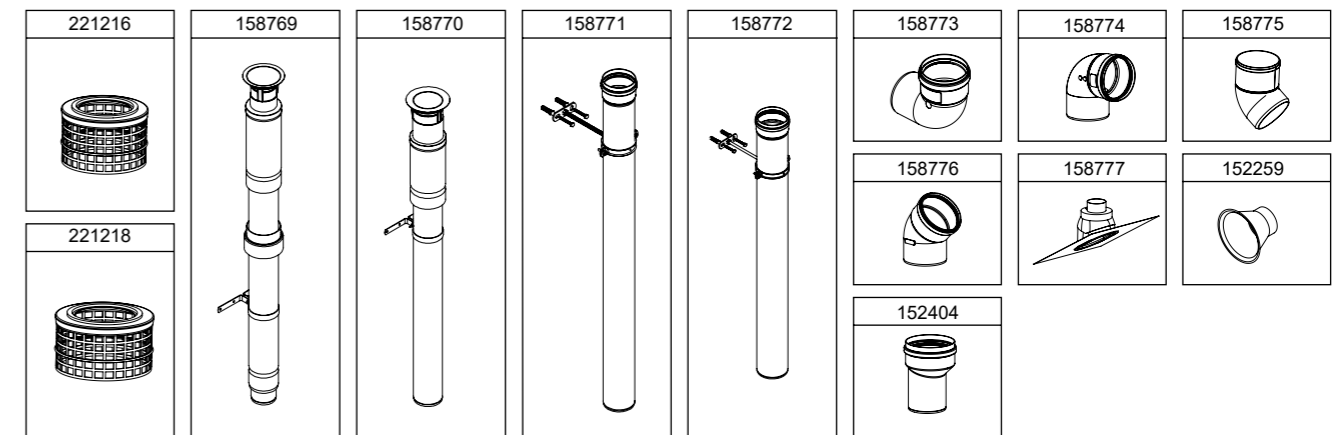

FLUE RESISTANCES

FLUE SYSTEMS

For concentric flue systems with elbows fitted, use the table to correct the maximum flue extension capability. Alternatively use the table to design the flue system, deducting the individual resistance of components from the maximum pressure drop allowed in the flue for that boiler. The maximum pressure drop allowed in the flue is given below.

PERMISSIBLE FLUE LENGTH

The maximum permissible flue lengths for each model are shown in Table 1 below, these lengths are inclusive of the terminal resistance. The value shown is the maximum available length for extension. The equivalent length of elbows is shown in Table 2.

TABLE 1

MAX PERMISSIBLE EQUIVALENT FLUE LENGTH (INC TERMINAL RESISTANCE) METRES				
Flue Size	CONCENTRIC		OPEN FLUE	
	80/125	100/150	80	100
Model				
30/30P	33	-	65	-
40/40P	30	-	70	-
60/60P	17.5	28	25	-
80/80P	10	18	15.3	-
100	-	10	-	20
120	-	9	-	49
150	-	6	-	32

TABLE 2

Size	EQUIVALENT LENGTH OF ELBOWS (METRES)			
	CONCENTRIC		OPEN FLUE	
	80/125	100/150	80	100
45°	0.85	1.25	0.45	0.60
90°	1.6	1.9	1.0	1.0

EXAMPLES OF FLUE LENGTH CALCULATION							
MODEL	FLUE TYPE	MAX PERMISSIBLE EQUIVALENT LENGTH (TABLE 1)	ELBOWS			TOTAL EQUIVALENT LENGTH	MAX PERMISSIBLE STRAIGHT LENGTH
			TYPE	EQUIVALENT LENGTH (TABLE 2)	NO		
60	80/125	17.5	90	1.6	2	3.2	14.3
60	100/150	28	90	1.9	2	3.8	24.2
80	80/125	10	90	1.6	3	4.8	5.2
120	100/150	9	90	1.9	4	7.6	1.4

FOR OWN BUILT OPEN FLUE USE THIS:

MAXIMUM ALLOWABLE PRESSURE DIFF & FLUE LENGTH FLUES INCLUDING TERMINAL		
MODEL	FLUE SIZE	PRESSURE DIFF (Pa)
30/30P	80/125	180
40/40P	80/125	227
60/60P	80/125	150
80/80P	80/125	312
100	100/150	220
120	100/150	473
150	100/150	332

EXAMPLES OF CALCULATING FLUE RESISTANCES/LENGTHS

EXAMPLE 1 (CONCENTRIC)

HORIZONTAL FLUE FOR EVOMAX 2 40	
	Resistance (m)
Flue size	80/125
Max permissible flue run	30
2 x 90° elbow	2 x 1.6 = 3.2
Total flue length available	30 - 3.2 = 26.8

Therefore this installation is acceptable as only a 2m run.

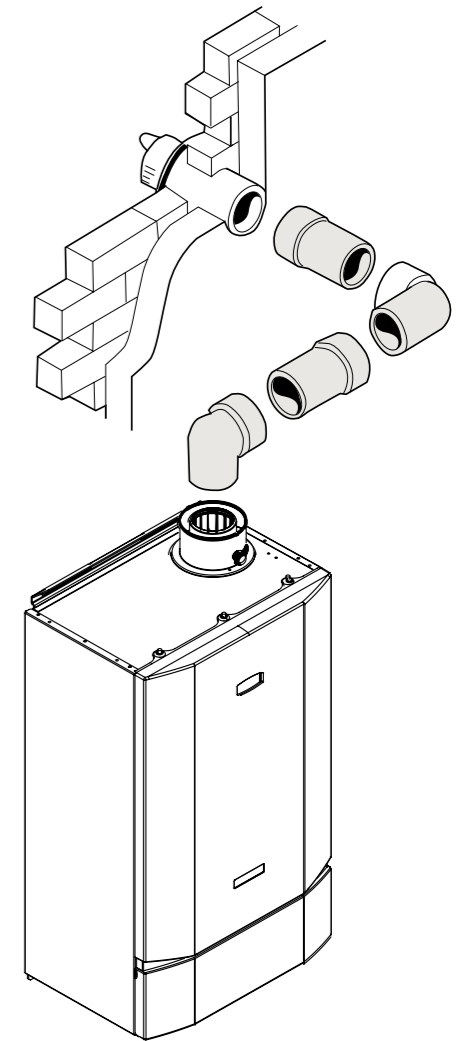

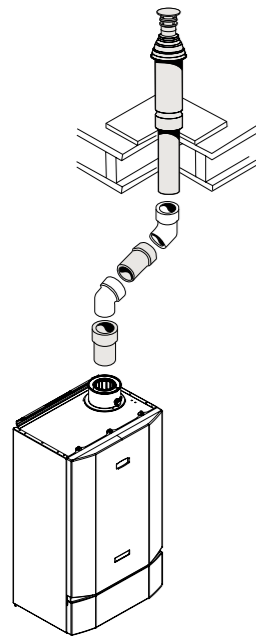

EXAMPLE 2 (CONCENTRIC)

VERTICAL FLUE FOR EVOMAX 2 80	
	Resistance (m)
Flue Size	80/125
Max permissible flue run	10
2 x 45°	2 x 0.85 = 1.7
Total Flue Resistance	10 - 1.7 = 8.3

EXAMPLE 3 (OPEN FLUE)

OPEN FLUE FOR EVOMAX 2 30	
	Resistance (m)
Flue Size	80
Max permissible flue run	65
2 x 45° elbow	2 x 0.45 = 0.9
Total Flue Resistance	65 - 0.9 = 64.1

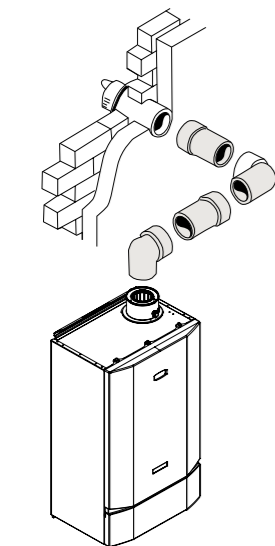

EXAMPLE 4 (CONCENTRIC)

HORIZONTAL FLUE FOR EVOMAX 2 120	
	Resistance (m)
Flue Size	100/150
Max permissible flue run	9
2 x 90° elbow	2 x 1.9 = 3.8
Total Flue Resistance	9 - 3.8 = 5.2



MULTILINE CASCADE

The Multiline Flue Cascade is one of the latest additions to the flue accessory range from Ideal, designed specifically for the Evomax 2 range. Available for installations up to 600kW as both a starter kit and extension pack the Multiline system enables Evomax 2 boilers installed as open flue to be connected via a common flue header. This creates a single flue connection point for a flue specialist to design to knowing that the boiler installation is efficient and safe.

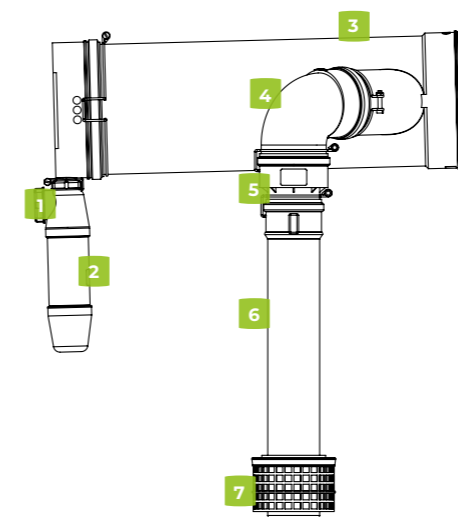

- Simple system ordering with a starter kit and extension kits
- Starter kit includes, appliance connection, non-return flue damper, condensate tee and trap and all clips to secure the flue
- Extension pack includes appliance connection, non-return flue damper, and all clips to secure the flue
- Available for both 80/125 & 100/150 flue adaptor applications
- For installations up to 600kW
- Type B23 flue
- Designed specifically to work efficiently with Evomax 2 boilers with commissioning simply completed by selecting Multiline flue from the installer set up menu
- The perfect addition for Evomax 2 installations using either the standard height or low frame and header kits

	PRODUCTS	STARTER KIT	EXTENSION KIT
1	End Cap	<input checked="" type="checkbox"/>	
2	Siphon / Condensate trap	<input checked="" type="checkbox"/>	
3	Collector Pipe (200 dia)	<input checked="" type="checkbox"/>	<input checked="" type="checkbox"/>
4	Elbow (90 x 100)	<input checked="" type="checkbox"/>	<input checked="" type="checkbox"/>
5	Expander (80/125 flue adaptor kits only)	<input checked="" type="checkbox"/>	<input checked="" type="checkbox"/>
6	Flue Extension Tube (80 or 100)	<input checked="" type="checkbox"/>	<input checked="" type="checkbox"/>
7	Air Intake Grill	<input checked="" type="checkbox"/>	<input checked="" type="checkbox"/>

The Cascade flue system is supplied in two kits. A Starter Kit & an Extension Kit. Wire retaining clips are also provided to prevent movement of the tube connections due to expansion and contraction. These must be fitted to the ductwork to ensure safe operation of the system.

OPERATION SYSTEM CONFIGURATIONS

OPTION	GAS TYPE	EVOMAX MODELS	MAX NUMBER OF BOILERS	MAX SYSTEM CAPACITY
1	Natural gas	Combinations of 100, 120, 150	6	600kW
2		Combinations that include a 30, 40, 60 or 80	6	400kW
3	Propane	Combinations of 100P or 120P	6	600kW
4		Combinations of 30P, 40P, 60P, 80P	6	400kW

EVOMAX 2 PLUME KIT

Flue height = 570mm from the top of the first boiler in the system.
Increase the height 29mm for each adjacent boiler.

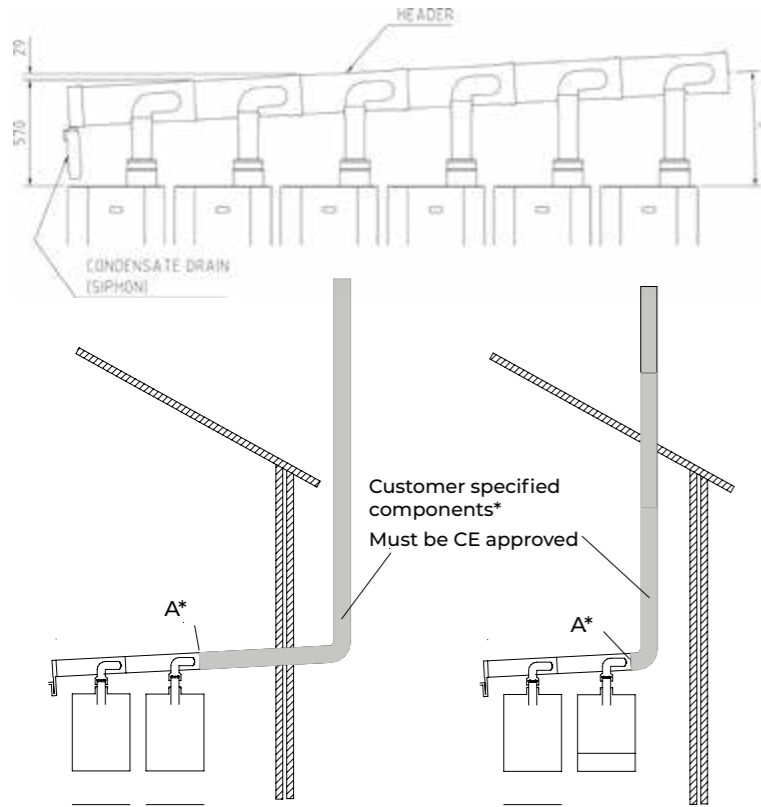

UIN	DESCRIPTION
220925	Multiline Starter Kit 80/125
220926	Multiline Extension Kit 80/125
220927	Multiline Starter Kit 100/150
220928	Multiline Extension 100/150

*Multiline flue supplied to point A. Customers are to fabricate / supply B type flue system to termination point within flue resistance parameters.

At the maximum system capacity the static pressure generated against the flue resistance at position [A] must not exceed the value Pmax quoted in the table below.

The Evomax 2 Plume Kit is one of the latest additions to the flue accessory range from Ideal, designed specifically for the Evomax 2 range. Available for Evomax 2 boilers up to 150kW the Plume Kit can be used to relocate the flue terminal up to 10m.

- Suitable for all Evomax 2 up to 150kW
- Available for both 80/125 & 100/150 flue applications
- Plume kit offers terminal relocation up to 10m

- Includes standard appliance connector, horizontal flue kit, special rain collar, external plume kit 1m and terminal
- Offers neat solutions for awkward flue installations where the terminal requires relocation

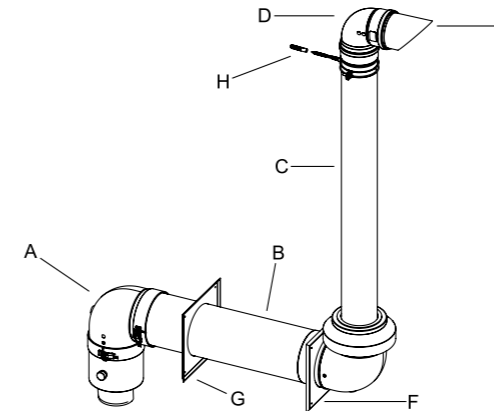

PRODUCTS	
A	Turret elbow
B	Flue terminal with rain cowl & air terminal assembly
C	1 Meter extension tube
D	90 degree elbow
E	Flue terminal end
F	External wall plate
G	Internal wall plate
H	Wall bracket

EVOMAX 2 MODEL OUTPUT		CASCADE SYSTEM LIMITS		COMBUSTION PRODUCTS DATA		
Model		Maximum System Capacity	Maximum Permissible Header Pressure 'A' (Static)	Max rate CO ₂	Min rate CO ₂	Temperature Max
Max	Min	Hmax	Pmax	±0.5	±0.5	
kW	kW	kW	Pa	%	%	C
30	7.5	400	40	9.7	9.0	72
40	10					
60	15					
80	20					
100	25	600	80			
120	30					
150	37.5					
30P	7.5	400	40	11.4	10.6	
40P	10					
60P	15					
80P	20					
100P	25	600	80			
120P	30					

OPERATION

EVOMAX 2 PLUME KIT - PACKAGED OPTIONS

UIN	DESCRIPTION	DRAWING IDENTIFIER	COMPATIBLE WITH EVOMAX 2 30, 30P, 40, 40P, 60, 60P, 80, 80P	COMPATIBLE WITH EVOMAX 2 100, 100P, 120, 120P, 150
213274	Plume kit 1m extension 80/125	A	<input checked="" type="checkbox"/>	
213272	Plume kit 90 deg elbow 80/125	B	<input checked="" type="checkbox"/>	
213273	Plume kit 45 deg elbows (pair) 80/125	C	<input checked="" type="checkbox"/>	
213277	Plume kit 1m extension 100/150	A	*	<input checked="" type="checkbox"/>
213275	Plume kit 90 deg elbow 100/150	B	*	<input checked="" type="checkbox"/>
213276	Plume kit 45 deg elbows (pair) 100/150	C	*	<input checked="" type="checkbox"/>

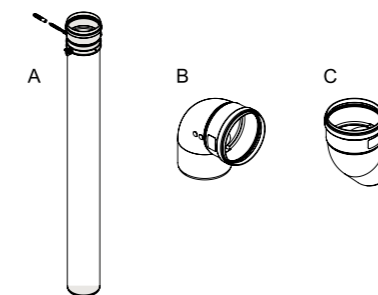

*Note: The 100/150mm Plume Kit system can also be used on Evomax 2 80, 80P, 60 & 60P model variants if internal concentric wall horizontal flue adaptor is used (Part No. 158660). See Evomax 2 installation manual for details.

EVOMAX PLUME KIT - 80/125

UIN	DESCRIPTION
220922	Plume kit 80/125
213274	Plume kit 1m extension 80/125
213272	Plume kit 90 deg elbow 80/125
213273	Plume Kit 45 deg elbow 80/125 (Pair)

EVOMAX PLUME KIT - 100/150

UIN	DESCRIPTION
220923	Plume kit 100/150
213277	Plume kit 1m extension 100/150
213275	Plume kit 90 deg elbow 100/150
213276	Plume kit 45 deg elbow 100/150 (Pair)

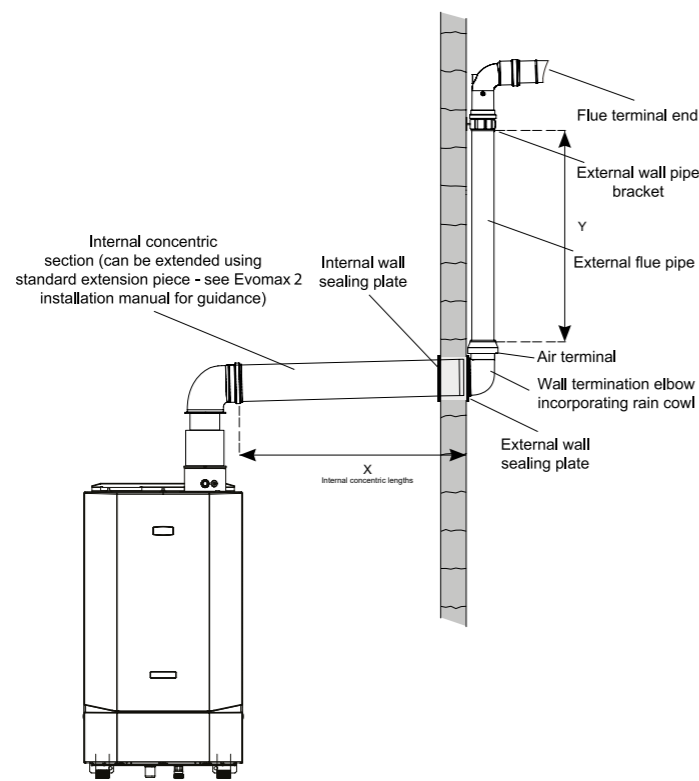

80 / 125 DIA FLUE ~ MAXIMUM PERMISSIBLE FLUE LENGTHS (M)				
Evomax 2 Model	30/30P	40/40P	60/60P	80/80P
Y	X			
0.5	30.2	27.2	14.7	7.2
2.0	29.5	26.5	14.0	6.5
4.0	28.6	25.6	13.1	5.6
6.0	27.7	24.7	12.2	4.7
8.0	26.8	23.8	11.3	3.8
10.0	25.9	22.9	10.4	2.9

100 / 150 DIA FLUE ~ MAXIMUM PERMISSIBLE FLUE LENGTHS (M)					
Evomax 2 Model	60/60P	80/80P	100/100P	120/120P	150
Y	X				
0.5	25.0	15.0	7.0	6.0	3.0
2.0	24.6	14.6	6.6	5.6	2.6
4.0	24.0	14.0	6.0	5.0	2.0
6.0	23.5	13.5	5.5	4.5	1.5
8.0	22.9	12.9	4.9	3.9	0.9
10.0	22.4	12.4	4.4	3.4	0.4

FLUE TYPES

Before ventilation can be sized we need to identify the type of flue system.

Type B – Open flue: takes air from the plant room (adequate ventilation must be available).

Type C – Room sealed: takes air from outside

We also need to know the classification of the room type.

- Boiler house – a dedicated building for the installation of boilers and ancillary plant.
- Boiler room – a dedicated room within a building for the installation of boilers and ancillary plant.
- Enclosure – space in which a boiler(s) is installed, which is not large enough to permit access for work other than maintenance via external access.
- Plant room – a room in a building that houses plant and machinery.
- Open space – e.g. in a warehouse.

CLASSIFICATION OF TYPE B FLUES

Appliance type	Primary definition	Natural draught	Fan down stream of heat exchanger	Fan upstream of heat exchanger
B open flue	B1- appliance with a draught diverter	B11	B12 B14*	B13
	B2 – appliance without draught diverter	B21	B22	B23

*Appliance fan also downstream of draught diverter

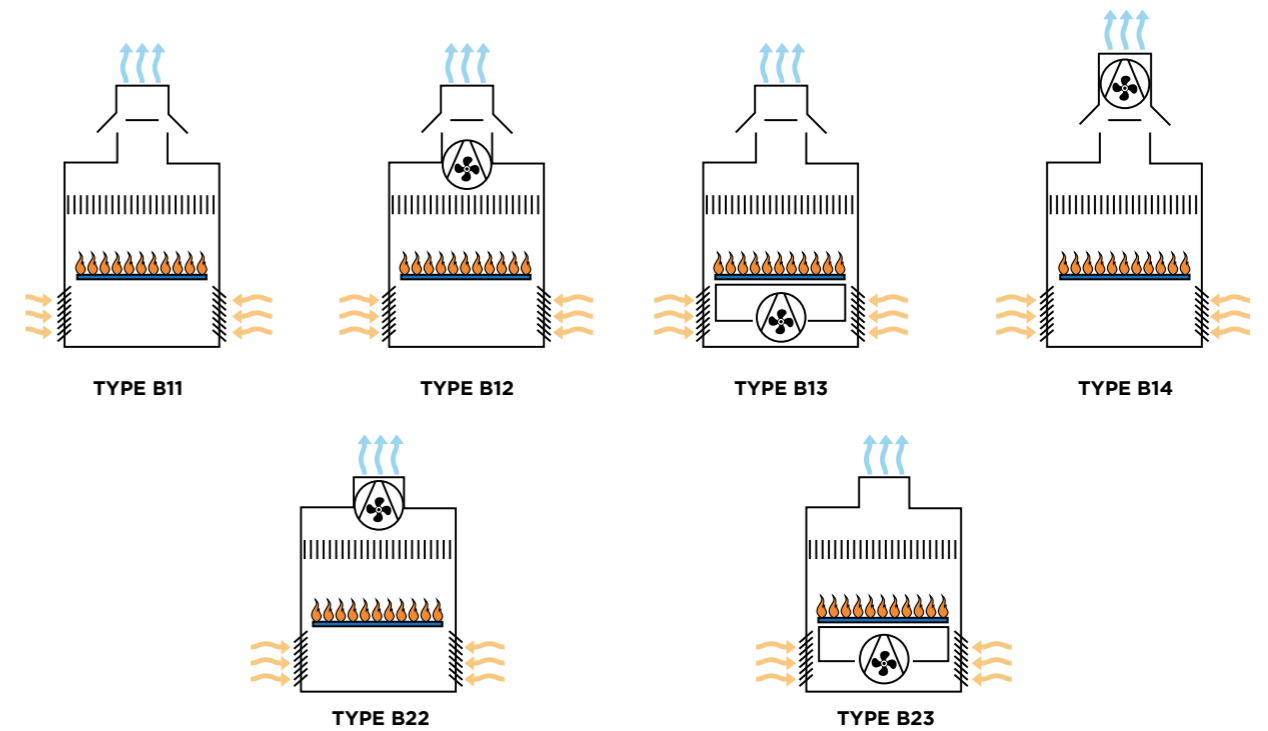

Where 2 or more gas fired boilers are connected to a common natural draught flue, the boilers must be installed in the same room and have the same type of burner system. A gas fired boiler and a solid fuel or biomass boiler must not discharge into the same flue. A gas fired boiler and a liquid fired fuel boiler can discharge into the same flue providing they are both installed in the same room and are force draught.

Appliance type	Primary definition	Natural draught or fan draught		
		Natural draught	Fan down stream of heat exchanger	Fan upstream of heat exchanger
C type Room sealed	C1- appliances with a horizontal balanced flue/inlet air ducts to outside atmosphere.	C11*	C12	C13*
	C2 – appliance flue connects to a common duct system for multi-appliance installations (the common duct system is part of the building)	C21	C22	C23
	C 3 - appliance with vertical balanced flue/ inlet air ducts to outside atmosphere.	C31	C32*	C33*
	C4 – appliance with flue system that connects to a common duct system e.g. 'U' duct flue system.	C41	C42	C43
	C5 – appliance with a non-balanced flue/ inlet air duct system.	C51	C52	C53
	C6 – appliance sold without a flue system	C61	C62	C63
	C7 – appliance connected to a vertical flue to outside atmosphere with the air ducts in the loft (vertex)	C71	C72	C73
	C8- appliance with a non-balanced flue system with an air supply from outside atmosphere and flued into a common duct system.	C81	C82	C83

*Appliance fan also downstream of draught diverter

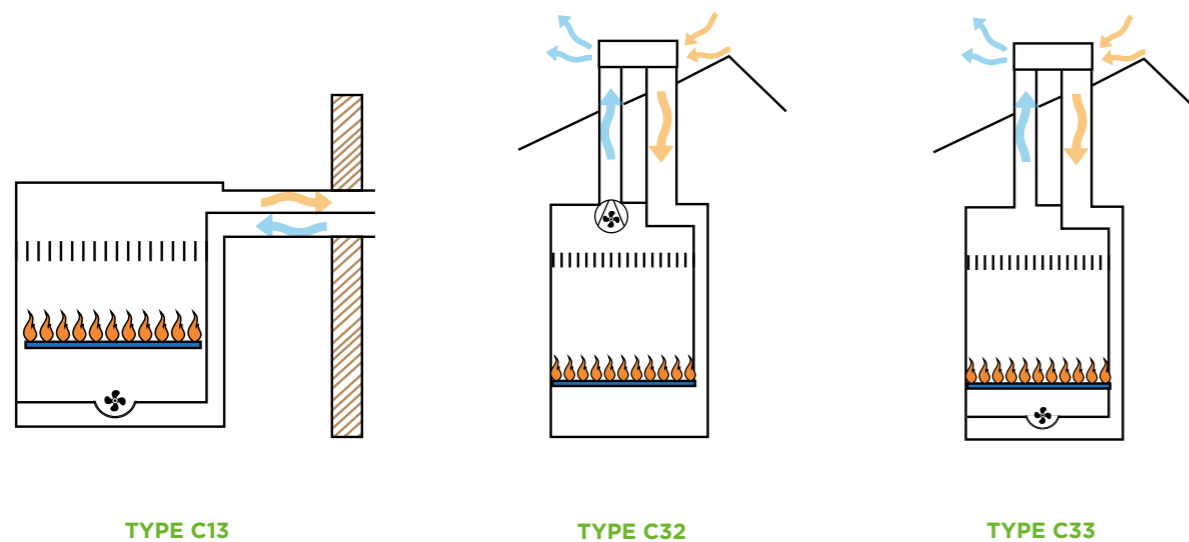

GUIDE TO FLUE INSTALLATION & REGULATIONS

There are many different regulations relating to flues and ventilation. This document will not cover all of them but assist in obtaining information and guidance, and provide useful and practical information.

This guide looks at common standards used to determine the requirements for flue and ventilation installation requirements and should not be used as a sole reference for flue regulations. Please also remember to use the installation and service manual for specific guidance for each boiler and to refer to the relevant standards.

COMMERCIAL BOILERS (70kW – 1.8MW)

- BS6644** Specification for the installation and maintenance of gas-fired hot water boilers of rated inputs between 70 kW (net) and 1.8 MW (net) (2nd and 3rd family gases). In IE refer to I.S. 820.
- IGEM UP10** Installation of flued gas appliances in industrial and commercial premises.
- Building Regs Part J** Combustion appliances and heat storage, gives advice on how to comply with Building Regulations.
- Clean Air Act (1956 Amendment)** A UK Parliament Act passed in response to London's Great Smog of 1952.

The Act introduced a number of measures to reduce air pollution, especially by introducing 'smoke control areas' in some towns and cities in which only smokeless fuels could be burned. By shifting homes' sources of heat towards cleaner coals, electricity, and gas, it reduced the amount of smoke pollution and sulphur dioxide from household fires. Reinforcing these changes, the Act also included measures to relocate power stations away from cities, and for the height of some chimneys to be increased.

The Act was an important milestone in the development of a legal framework to protect the environment. Although smog is no longer an issue, more recent editions of the Clean Air Act have maintained control of emissions and heights of flues.

WHEN SHOULD I USE COMMERCIAL FLUE REQUIREMENT LEGISLATION AND GUIDANCE?

BS5440 covers domestic installations up to 70kW net input, however if an appliance is to be installed in a factory location even if under 70kW then the commercial requirements of IGEN UP10 & BS6644 must be adopted.

Similarly if a cascade boiler installation is fitted and the total input exceeds 70kW then the commercial flues and ventilation should be adopted.

WHAT IS GUIDANCE AND WHAT IS MANDATORY?

British Standards are a mandatory requirement. The approved documents offer guidance on how to comply and are not legally binding unless the manufacturer of the appliance stipulates them in the installation manual. It is prudent however to follow them because they would likely be used in a court of law as the minimum expected by a competent person to install a safe system.

Building Regs are a mandatory requirement as set out in Government legislation.

IGEM Documents offer guidance in the same way as British standards. However these have been set and adopted by a board of industry experts and represent current best practice and are aligned with National/International legislation and standards.

Clean Air Act – This is a mandatory requirement as set out in Government legislation.

Gas Safety (Installation and Use) Regulations 1998 – These are mandatory and set out the requirements for safe installations.

CLEAN AIR ACT - THE FACTS

The Act applies to gas (and other fuels) fired appliance installations generally but with specific requirements for installations exceeding 333 kW net heat input including approval of the height of the chimney by the Local Authority. The essential requirements are that flue discharges are not to cause a nuisance to others or be a hazard to health.

In 1956 there was a clean air act memorandum that stated appliances with gross input of 150kW must terminate vertically. This has no foundation in law and was not written for modern high efficiency products. To this effect the current guidance suggests that all installations from 135kW net input that wish to terminate horizontally should be subject to a risk assessment which can be found in IGEN UP10.

All installations are subject to the clean air act requirements:-

Installations below 333kW net heat input can terminate horizontally at low level subject to a risk assessment and complying with all other clearance distances as defined in IGEN UP10.

- Appliance inputs greater than 333kW net need prior approval from the Local Authority with position of flue termination agreed by them.
- No terminal fitted to natural draught flues should be less than 170mm.
- Terminal positions for fanned or natural draught flues shall be clear of obstructions and openings into buildings. Wall terminations shall be directed away from the building.
- Vertical outlets must be the minimum required above the roof level.
- Any horizontal outlet below 2m must be guarded and a minimum of 300mm above ground level.

TERMINATION POSITIONS APPLIANCES OVER 70KW NET INPUT

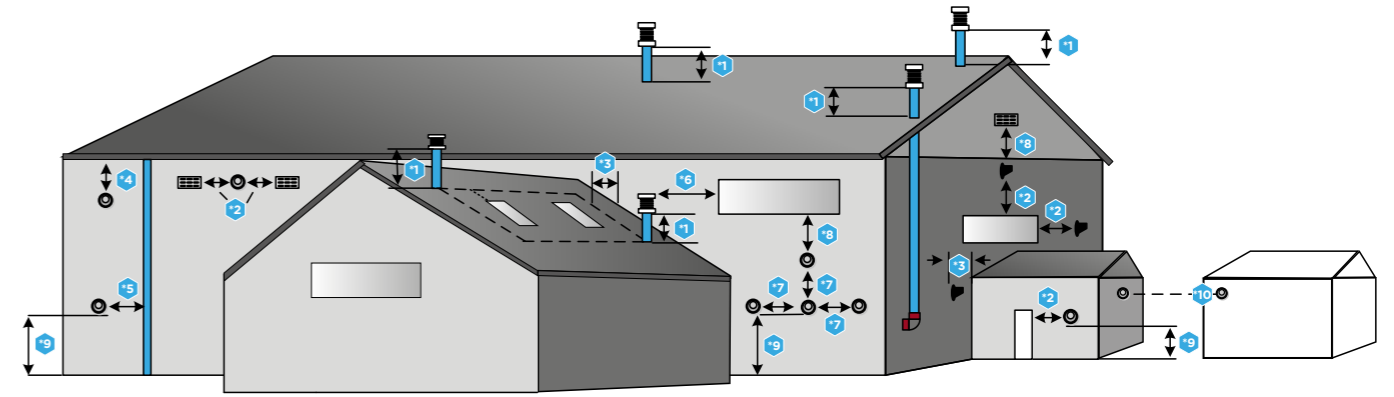

Key to Diagram:

- *1 - Minimum termination height for ridged and flat roofs.
- *2 - Minimum horizontal termination distance from openings i.e. doorways, windows, ventilation grilles, etc.
- *3 - Minimum horizontal termination distance from adjacent walls or obstructions.
- *4 - Minimum distance to be 200 mm for fan assisted appliances, 300 mm for room sealed natural draught appliances, see BS 5440.
- *5 - Minimum distance to be 150 mm, see BS 5440.
- *6 - Minimum termination distance from openings i.e. doorways, windows, ventilation grilles, etc.
- *7 - Minimum distance of centres of flue terminal, see manufacturer's instructions.
- *8 - Minimum distance below terminal or opening 2.5 m.
- *9 - Minimum 300mm above the ground. If less than 2m subject to a risk assesment (fig.1).
- *10 - Opposing a terminal or flat surface.

SEE IGEN 10 FOR FURTHER DETAILS

1, 3 & 6 Minimum Height of Termination Located on a roof								
	70kW	80kW	100kW	120kW	150kW	200kW	240kW	300kW
Natural Draught	600mm	615mm	645mm	676mm	722mm	798mm	859mm	950mm
For other natural draught appliances use Distance = 1.5225 (net heat input kW) + 493.43								
Fanned Draught	300mm	327mm	380mm	433mm	513mm	646mm	753mm	913mm
For other fan draught appliances use Distance = 2.6644 (net heat input kW) +113.49								
For all sloped roofs over 20 degree pitch the terminal must be 1.5m away								
If the flue termination is within 2.5m of an adjacent structure then these heights above the structure will apply								

2 Minimum Horizontal Termination To Openings Into Buildings (side or above)								
	70kW	80kW	100kW	120kW	150kW	200kW	240kW	300kW
Open Flue and Fanned Draught	1500mm	1600mm	1790mm	1975mm	2265mm	2740mm	3120mm	3690mm
For other open flue fan draught inputs use Distance = 9.5156 x (net heat input) + 833.91								
Room Sealed Fanned Draught	600mm	675mm	820mm	960mm	1180mm	1540mm	1830mm	2265mm
For other room sealed fan draught inputs use Distance = 7.232 x (net heat input) + 93.708								
The minimum distance below in all cases is 2500mm								

10 Room Sealed Fanned Draught Minimum Horizontal Termination To Opposing Walls/Terminals								
	70kW	80kW	100kW	120kW	150kW	200kW	240kW	300kW
Opposing Flat Surface	1000mm	1231mm	1694mm	2156mm	2850mm	4006mm	4931mm	6319mm
For other inputs use Distance = 23.126 x (net heat input) - 618.84								
Opposing Terminal	600mm	675mm	820mm	960mm	1180mm	1540mm	1830mm	2265mm
For other inputs use Distance = 19.32 x (net heat input) + 647.59								

VENTILATION REQUIREMENTS OF COMMERCIAL BOILERS OVER 70KW NET INPUT

ROOM SEALED APPLIANCES, TYPE C IN PLANT ROOMS

FLUE TYPE	VENTILATION DIRECT TO OUTSIDE AIR (cm ² per kW net heat input)	
	HIGH	LOW
(TYPE C)	2	2

OPEN FLUED APPLIANCES, TYPE B IN PLANT ROOMS (ADDITIONAL RECOMMENDATIONS)

Natural Ventilation cm ² kw (net) heat input for open flue boilers located in a boiler house				
	(A) Boiler House	(B) Enclosure	Summer usage* greater than 50% up to 75%	Summer usage* greater than 75% up to 100%
High	2	5	+1	+2
Low	4	10	+1	+2

*for boilers in use for more than 50% of the time during the summer months, additional ventilation needs to be added to those in columns A and B

OPEN FLUED APPLIANCES, TYPE C IN PLANT ROOMS (ADDITIONAL RECOMMENDATIONS)

Natural Ventilation cm ² kw (net) heat input for open flue boilers located in a boiler house					
	(A) Boiler House	(B) Enclosure		Summer usage* greater than 50% up to 75%	Summer usage* greater than 75% up to 100%
		To a room or internal space	Direct to outside air		
High	2	10	5	+1	+2
Low	2	10	5	+1	+2

*for boilers in use for more than 50% of the time during the summer months, additional ventilation needs to be added to those in columns A and B

For further information, please refer to:

- Manufacturer's instructions
- IGEN UP10
- BS6644

- High level ventilation openings shall be located as high as is reasonably practicable and preferably within 15% of the building height from the ceiling.
- Low level ventilation openings shall be within 1m of the floor for Natural Gas and within 250mm of the floor for LPG.
- For LPG it is preferable that low level ventilation openings are located at floor level.
- Ventilation to an internal space is not generally recommended unless a Risk Assessment has been completed.
- The air supplied for boiler room ventilation shall be such that the maximum temperature within the boiler house is:
 - 25 °C at floor level (or 100mm above floor level)
 - 32 °C at mid level (1.5 m above floor level)
 - 40 °C at ceiling level (or 100mm below ceiling level)

MECHANICAL VENTILATION

- Mechanical ventilation can be a combination of mechanical inlet and outlet or mechanical inlet and natural ventilation outlet.
- The fans shall be selected and controlled so as to not cause a negative pressure (relative to the outside atmosphere) developing in the boiler room.
- Interlocked to the gas appliance.

Minimum Quantity of Mechanical Ventilation

Mechanical ventilation m ³ /hr per kW net heat input				
	(A) Min inlet air m ³ /hr	(B) Difference between inlet and extract air† m ³ /hr	Summer usage greater than 50% up to 75%	Summer usage†† greater than 75% up to 100%
Boiler(s) with draught diverter	2.8	2.07 ±0.18	+0.72	+1.44
Boiler(s) without draught diverter†††	2.6	1.35 ±0.18	+0.72	+1.44

†inlet air minus ventilation 2.8 - 2.07 = 0.73m³/hr

††For boilers in use for more than 50% of the time during the summer months, additional mechanical ventilation needs to be added to those columns A and B

††† with or without draught stabilisers

WATER TREATMENT

IMPORTANT

The application of any other treatment to this product may render the guarantee of Ideal Heating invalid. Ideal Heating recommend Water Treatment in accordance with the Benchmark Guidance Notes on Water Treatment in Central Heating Systems. If water treatment is used Ideal Heating recommend only the use of Scalemaster Gold 100, Fernox, MB-1, Adey MCI, Sentinel-X100, CALMAG CM100 inhibitors and associated water treatment products, which must be used in accordance with the manufacturers' instructions.

NOTES

1. It is most important that the correct concentration of the water treatment products is maintained in accordance with the manufacturers' instructions.
2. If the boiler is installed in an existing system any unsuitable additives MUST be removed by thorough cleansing. BS 7593:2006 details the steps necessary to clean a domestic heating system.
3. In hard water areas, treatment to prevent lime scale may be necessary - however the use of artificially softened water is NOT permitted.
4. Under no circumstances should the boiler be fired before the system has been thoroughly flushed.

FOR FURTHER INFORMATION CONTACT:

Fernox Alent plc
Forsyth Road, Sheerwater, Woking,
Surrey GU21 5RZ
Tel: +44 (0) 870 601 5000

Sentinel Performance Solutions
7560 Daresbury Park
Daresbury, Warrington
Cheshire
WA4 4BS
Tel: 0800 389 4670
www.sentinelprotects.com

Scalemaster Water Treatment Products
Emerald Way, Stone, Staffordshire
ST15 0SR
Tel: 01785 811636

Calmag Ltd.
Riverview Buildings
Bradford Road, Riddlesden,
Keighley, West Yorkshire
BD20 5JH
Tel: +44 (0) 1535 210 320

Adey Innovation Ltd
Unit 2, St Modwen Park,
Haresfield,
Stonehouse GL10 3EX
Tel: +44 (0) 1242 546700

DOMESTIC BOILERS (UP TO 70kW)

BS5440

Flues and ventilation for gas appliances of rated input not exceeding 70 kW net (1st, 2nd and 3rd family gases). Specification for the installation and maintenance of ventilation provision for gas appliances. In I.E refer to I.S. 813.

FLUE TERMINATION POSITION

Due to the high efficiency of these boilers plumbing will occur. For this reason vertical termination is recommended, and in any case, terminal positions which could cause problems should where possible be avoided.

Particular care should be taken in the case of large multiple boiler installations, and complying with the requirements of the Clean Air Act. The information below is extracted from BS. 5440 Pt. 1 and is for boilers with heat inputs not exceeding 70kW nett, and the latest Building Regulation Part J. Detailed reference should still be made to these standards. In IE refer to I.S. 813:2002.

CONCENTRIC WALL TERMINAL POSITIONS	MINIMUM SPACING
A. Below an opening (1)	300mm
B. Above an opening (1)	300mm
C. Horizontally to an opening (1)	300mm
D. Below gutters, soil pipes or drain pipes	75mm
E. Below eaves	200mm
F. Below balcony or car port roof	200mm
G. From a vertical drain pipe or soil pipe	150mm
H. From an internal or external corner or to a boundary alongside the terminal	300mm
I. Above ground, roof or balcony level	300mm
J. From a surface or a boundary facing the terminal	600mm
K. From a terminal facing the terminal	1200mm
L. From an opening in the car port into the building	1200mm
M. Vertically from a terminal on the same wall	1500mm
N. Horizontally from a terminal on the same wall	300mm
CONCENTRIC ROOF TERMINAL POSITIONS	
Directly below an opening, air brick, windows, etc.	300mm
Below plastic/painted gutters	500mm*
Below painted surface	500mm*
Below eaves or balcony	500mm
From wall	1000mm
Below Velux window	2000mm
Above or side of Velux window	600mm

* May be reduced to 300mm if a shield fitted. (1) An opening here means an openable element, such as a openable window, or a fixed opening such as an air vent. However, in addition, the outlet should not be nearer than 150mm (fanned draught) to an opening into the building fabric formed for the purpose of accommodating a built in element, such as a window frame.

If the terminal is fitted less than 500 mm below plastic gutters, painted eaves or any other painted surface then an aluminium shield at least 1m long should be fitted to protect the surface. For positioning of open flue terminals reference should be made to BS5440 Pt. 1. In IE refer to I.S. 813:2002

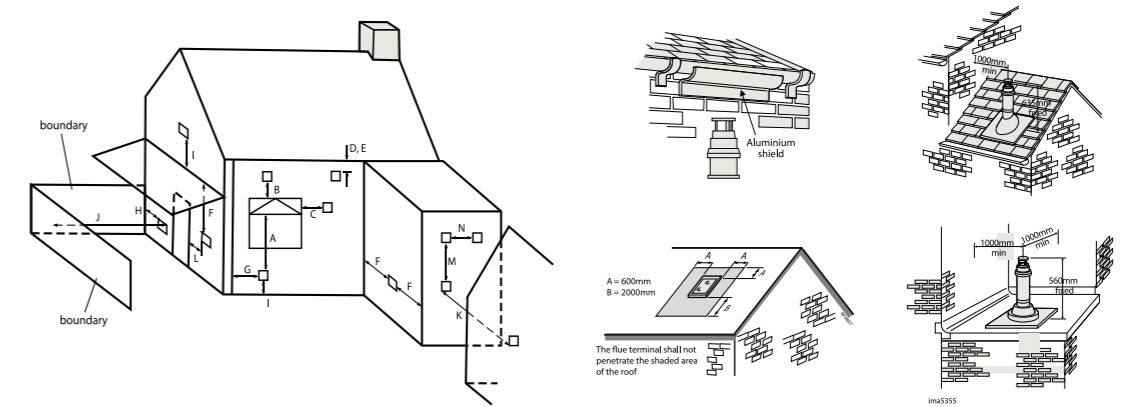

Heat inputs in excess of 70kW nett.

For boiler installations with total heat inputs in excess of 70kW nett, reference should be made to BS6644. In IE refer to I.S. 820:2000.

VENTILATION

The ventilation requirements of these boilers is dependant on the type of flue system used, and their heat input. All vents must be permanent with no means of closing, and positioned to avoid accidental obstruction by blocking or flooding.

EVOMAX 2 30/30P, 40/40P, 60/60P

Detail reference should be made to BS5440 Pt. 2. In IE refer to the current edition of I.S. 813.

The following notes are for general guidance only: If installed as a room sealed appliance in a room or internal space, then no purpose provided ventilation is required. If installed as an open flued appliance in a room or internal space then a permanent air vent is required. The sizes given below are for vents directly communicating with outside air. For other situations refer to BS5440 Pt. 2. In IE refer to the current edition of I.S. 813.

If installed in a compartment, then permanent air vents are required at high and low level. These vents may communicate direct to outside air, or to a room/internal space. If to a room/ internal space, it must itself be adequately ventilated as above.

EVOMAX 2 VENTILATION REQUIREMENTS (NOT EXCEEDING 70KW NET INPUT) WHEN INSTALLED IN A COMPARTMENT

	ROOM SEALED APPLICATION - MIN. VENT FREE AREA (CM ²)						OPEN FLUE APPLICATION - MIN. VENT FREE AREA (CM ²)					
	TO A ROOM OR INTERNAL SPACE			TO OUTSIDE AIR			TO A ROOM OR INTERNAL SPACE			TO OUTSIDE AIR		
Boiler Size	30	40	60	30	40	60	30	40	60	30	40	60
High Level	310	410	610	155	205	305	310	410	610	155	205	305
Low level	310	410	610	155	205	305	620	820	1220	310	410	610

The temperature within the boiler room shall not exceed 25 °C within 100mm of the floor, 32 °C at mid height and 40 °C within 100mm of the ceiling.

CONDENSATE PUMPS

The condensate pump is designed to collect and remove condensate and can be used with high efficiency condensing boilers.

TECHNICAL INFORMATION

Maximum flow rate	440 litres/hour
Electrical supply	230V AC / 50-60 Hz 0.8amps
Alarm contact	NC 4 Amps resistive
Overheat protection	130 °C
Tank Capacity	2.0 Litres
Maximum vertical head	4.5m
Maximum horizontal length	30m

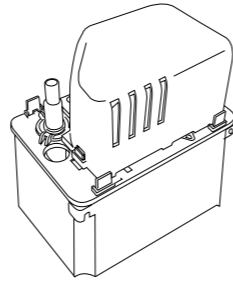

IDEAL COMMERCIAL BOILERS - CONDENSATE PUMP COMPATIBILITY

BOILER	COMPATIBLE
EVOMAX 2 - 30 - 150kW	✓
IMAX XTRA 2 - 80 - 280kW	✓
IMAX XTRA EL - 320 - 1240kW	✓
EVOMOD - 250 - 1000kW	✓
EVOJET - 150 - 1450kW	✓

TYPICAL CONDENSATE SYSTEM

TERMINATION TO DRAIN / GULLEY

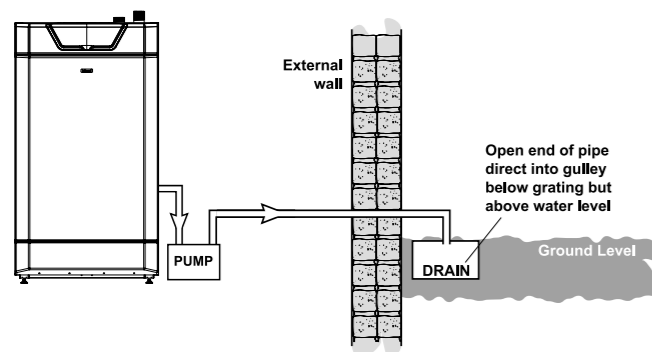

SEE INSTALLATION MANUAL FOR FULL INSTRUCTIONS AND SYSTEM OPTIONS



TRUSTED HEATING SOLUTIONS



HERE FOR YOU

At Ideal Commercial, we are committed to delivering the highest levels of customer service. With over a century of experience in the heating industry, we know how important confidence and trust is to our customers.

You can be confident to know that you're partnering with a British manufacturer that's supported by a dedicated national service team, delivering help and advice to you and your customers throughout the year.

Book online at: [idealheating.com](https://www.idealheating.com)

BOILER TRAINING

Our comprehensive one-day courses can be mixed and matched for individual installation and servicing companies. Each course uses a simple step-by-step approach with hands on training to ensure all aspects of commissioning, servicing, and fault finding can be dealt with quickly and efficiently.

NEED HELP?

Get in touch with us today.

SALES

Tel: 0844 543 6060

Fax: 0844 543 6181

TECHNICAL

Tel: 01482 498376

Fax: 01482 498621

commercial.services@idealheating.com

ideal

HEATING

COMMERCIAL

Sales:

0844 543 6060

Technical Help:

01482 498376

PO Box 103, National Avenue,
Kingston upon Hull, East Yorkshire,
HU5 4JN, United Kingdom

APPROVAL

These appliances are certified to G.A.D. 90/396 and B.E.D. 92/42 Safety and Performance Directives for gas boilers. Ideal Heating pursues a policy of continuous improvement in design and performance of its products and reserves the right to vary specification without notice. Statutory rights of the consumer are not affected.

PLEASE NOTE:

The information in this brochure was correct at the time of going to print. Ideal Heating reserve the right to make any modifications to product specifications or any other details, without prior notification. For further clarification, please enquire in writing to the head office address (address above).

